

bq40z50-R1 1 节、2 节、3 节和 4 节串联锂离子电池组管理器

1 特性

- 全集成 1 节、2 节、3 节和 4 节串联锂离子或锂聚合物电池组管理器及保护
- 下一代已获专利的 Impedance Track™ 技术可准确测量锂离子和锂聚合物电池中的可用电量
- 高侧 N 通道保护场效应晶体管 (FET) 驱动
- 充电或者静止状态时集成的电池均衡
- 可编程保护特性的完全阵列
 - 电压
 - 电流
 - 温度
 - 充电终止时间
 - CHG/DSG FET
 - 模拟前端 (AFE)
- 精密的充电算法
 - 日本电子与信息技术工业协会 (JEITA)
 - 增强型充电
 - 自适应充电
 - 电池均衡
- 支持 TURBO 升压模式
- 支持电池跳变点 (BTP)
- 诊断寿命数据监视器和黑匣子记录器
- 发光二极管 (LED) 显示
- 支持 2 线制系统管理总线 (SMBus) v1.1 接口
- 安全散列算法 (SHA-1) 认证
- 紧凑封装: 32 导线四方扁平无引线 (QFN) (RSM)

2 应用

- 笔记本/上网本
- 医疗与测试设备
- 便携式仪表

3 说明

bq40z50-R1 器件采用已获专利的 Impedance Track™ 技术，是一款基于电池组的单芯片全集成解决方案，针对 1 节、2 节、3 节和 4 节串联锂离子或锂聚合物电池组提供电量监测、保护及认证等一些列丰富的功能。

bq40z50-R1 器件利用其集成的高性能模拟外设，测量锂离子或锂聚合物电池的可用容量、电压、电流、温度和其他关键参数，保留准确的数据记录，并通过 SMBus v1.1 兼容接口将这些信息报告给系统主机控制器。

器件信息(1)

器件型号	封装	封装尺寸 (标称值)
bq40z50-R1	VQFN (32)	4.00mm x 4.00mm

(1) 如需了解所有可用封装，请见数据表末尾的可订购产品附录。

简化电路原理图

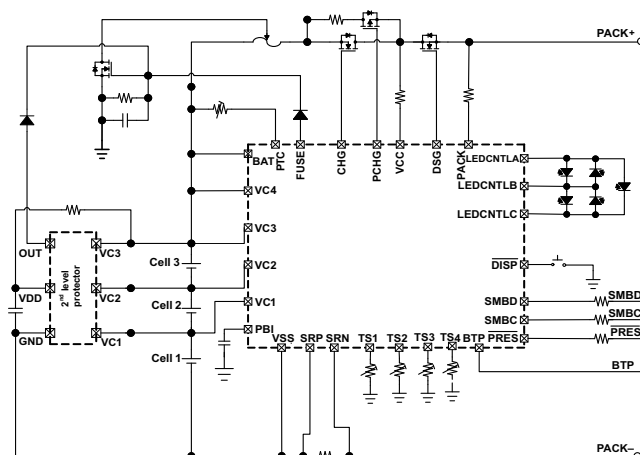

目录

1	特性	1			
2	应用	1			
3	说明	1			
4	修订历史记录	2			
5	说明 (续)	3			
6	Pin Configuration and Functions	3			
7	Specifications	7			
	7.1 Absolute Maximum Ratings	7			
	7.2 ESD Ratings	7			
	7.3 Recommended Operating Conditions	8			
	7.4 Thermal Information	8			
	7.5 Electrical Characteristics: Supply Current	8			
	7.6 Electrical Characteristics: Power Supply Control	8			
	7.7 Electrical Characteristics: AFE Power-On Reset	9			
	7.8 Electrical Characteristics: AFE Watchdog Reset and Wake Timer	9			
	7.9 Electrical Characteristics: Current Wake Comparator	9			
	7.10 Electrical Characteristics: VC1, VC2, VC3, VC4, BAT, PACK	10			
	7.11 Electrical Characteristics: SMBD, SMBC	10			
	7.12 Electrical Characteristics: PRES, BTP_INT, DISP	10			
	7.13 Electrical Characteristics: LEDCNTLA, LEDCNTLB, LEDCNTLC	11			
	7.14 Electrical Characteristics: Coulomb Counter	11			
	7.15 Electrical Characteristics: CC Digital Filter	11			
	7.16 Electrical Characteristics: ADC	11			
	7.17 Electrical Characteristics: ADC Digital Filter	12			
	7.18 Electrical Characteristics: CHG, DSG FET Drive	12			
	7.19 Electrical Characteristics: PCHG FET Drive	13			
	7.20 Electrical Characteristics: FUSE Drive	13			
	7.21 Electrical Characteristics: Internal Temperature Sensor	13			
	7.22 Electrical Characteristics: TS1, TS2, TS3, TS4	13			
	7.23 Electrical Characteristics: PTC, PTCEN	14			
	7.24 Electrical Characteristics: Internal 1.8-V LDO	14			
	7.25 Electrical Characteristics: High-Frequency Oscillator	14			
	7.26 Electrical Characteristics: Low-Frequency Oscillator	14			
	7.27 Electrical Characteristics: Voltage Reference 1	15			
	7.28 Electrical Characteristics: Voltage Reference 2	15			
	7.29 Electrical Characteristics: Instruction Flash	15			
	7.30 Electrical Characteristics: Data Flash	15			
	7.31 Electrical Characteristics: OCD, SCC, SCD1, SCD2 Current Protection Thresholds	16			
	7.32 Timing Requirements: OCD, SCC, SCD1, SCD2 Current Protection Timing	16			
	7.33 Timing Requirements: SMBus	17			
	7.34 Timing Requirements: SMBus XL	17			
	7.35 Typical Characteristics	19			
8	Detailed Description	22			
	8.1 Overview	22			
	8.2 Functional Block Diagram	22			
	8.3 Feature Description	23			
	8.4 Device Functional Modes	26			
9	Applications and Implementation	27			
	9.1 Application Information	27			
	9.2 Typical Applications	28			
10	Power Supply Recommendations	42			
11	Layout	43			
	11.1 Layout Guidelines	43			
	11.2 Layout Example	45			
12	器件和文档支持	47			
	12.1 文档支持	47			
	12.2 社区资源	47			
	12.3 商标	47			
	12.4 静电放电警告	47			
	12.5 Glossary	47			
13	机械、封装和可订购信息	47			

4 修订历史记录

NOTE: Page numbers for previous revisions may differ from page numbers in the current version.

日期	修订版本	注释
2015 年 7 月	*	最初发布版本

5 说明 (续)

bq40z50-R1 器件为主机系统提供最大的功率和电流，从而支持 Turbo 升压模式。该器件还支持电池跳变点，从而在预设的充电阈值状态向主机系统发送 BTP 中断信号。

bq40z50-R1 提供了基于软件的第 1 级和第 2 级安全保护，可防止出现过压、欠压、过流、短路、过载和过热情况以及其他与电池组和电池相关的故障。

具有针对认证码密钥的安全内存的 SHA-1 认证能够识别真正的电池组。

这个紧凑的 32 导线 QFN 封装在尽可能地提供电池电量测量应用的功能性和安全性的同时，最大限度地降低解决方案成本和智能电池的尺寸。

6 Pin Configuration and Functions

RSM Package
32-Pin VQFN with Exposed Thermal Pad
Top View

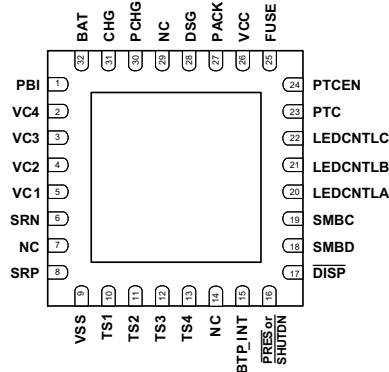

Pin Functions

PIN NAME	NUMBER	TYPE ⁽¹⁾	DESCRIPTION
PBI	1	P	Power supply backup input pin
VC4	2	IA	Sense voltage input pin for most positive cell, and balance current input for most positive cell
VC3	3	IA	Sense voltage input pin for second most positive cell, balance current input for second most positive cell, and return balance current for most positive cell
VC2	4	IA	Sense voltage input pin for third most positive cell, balance current input for third most positive cell, and return balance current for second most positive cell
VC1	5	IA	Sense voltage input pin for least positive cell, balance current input for least positive cell, and return balance current for third most positive cell
SRN	6	I	Analog input pin connected to the internal coulomb counter peripheral for integrating a small voltage between SRP and SRN where SRP is the top of the sense resistor.
NC	7	—	Not internally connected. Connect to VSS.
SRP	8	I	Analog input pin connected to the internal coulomb counter peripheral for integrating a small voltage between SRP and SRN where SRP is the top of the sense resistor.
VSS	9	P	Device ground
TS1	10	IA	Temperature sensor 1 thermistor input pin
TS2	11	IA	Temperature sensor 2 thermistor input pin
TS3	12	IA	Temperature sensor 3 thermistor input pin
TS4	13	IA	Temperature sensor 4 thermistor input pin
NC	14	—	Not internally connected
BTP_INT	15	O	Battery Trip Point (BTP) interrupt output

(1) P = Power Connection, O = Digital Output, AI = Analog Input, I = Digital Input, I/OD = Digital Input/Output

Pin Functions (continued)

PIN NAME	NUMBER	TYPE ⁽¹⁾	DESCRIPTION
$\overline{\text{PRES}}$ or $\overline{\text{SHUTDN}}$	16	I	Host system present input for removable battery pack or emergency system shutdown input for embedded pack
$\overline{\text{DISP}}$	17	—	Display control for LEDs
SMBD	18	I/OD	SMBus data pin
SMBC	19	I/OD	SMBus clock pin
LEDCNTLA	20	—	LED display segment that drives the external LEDs depending on the firmware configuration
LEDCNTLB	21	—	LED display segment that drives the external LEDs depending on the firmware configuration
LEDCNTLC	22	—	LED display segment that drives the external LEDs depending on the firmware configuration
PTC	23	IA	Safety PTC thermistor input pin. To disable, connect both PTC and PTCEN to VSS.
PTCEN	24	IA	Safety PTC thermistor enable input pin. Connect to BAT. To disable, connect both PTC and PTCEN to VSS.
FUSE	25	O	Fuse drive output pin
VCC	26	P	Secondary power supply input
PACK	27	IA	Pack sense input pin
DSG	28	O	NMOS Discharge FET drive output pin
NC	29	—	Not internally connected
PCHG	30	O	PMOS Precharge FET drive output pin
CHG	31	O	NMOS Charge FET drive output pin
BAT	32	P	Primary power supply input pin

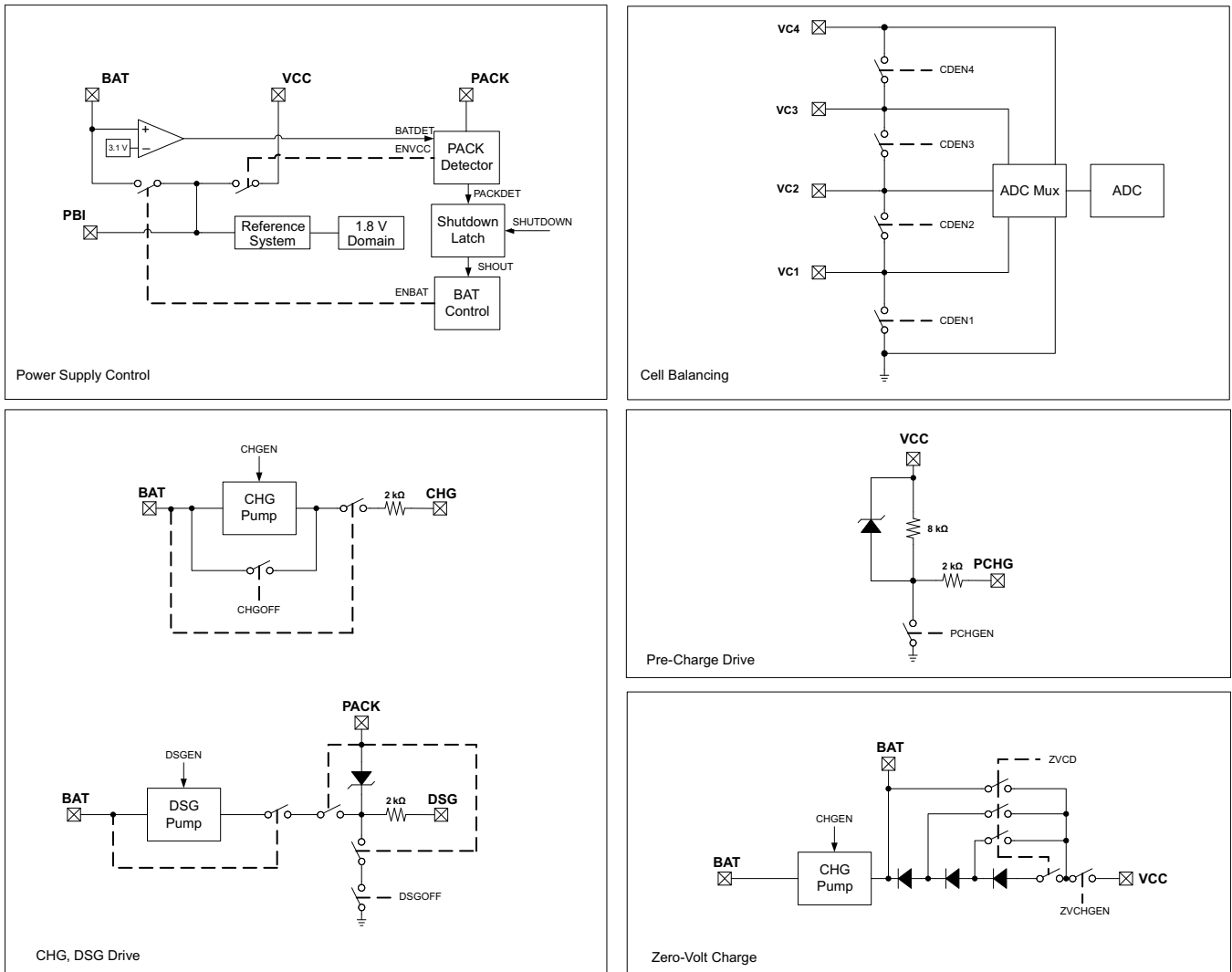
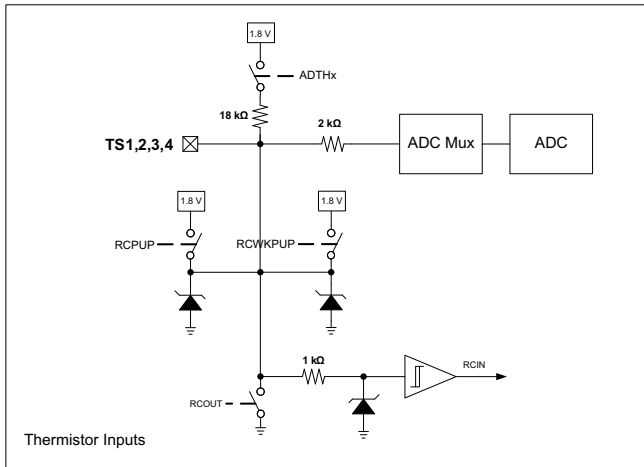
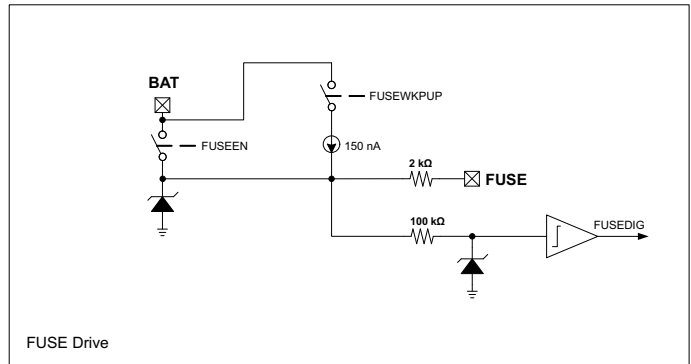

Figure 1. Pin Equivalent Diagram 1



Thermistor Inputs



FUSE Drive

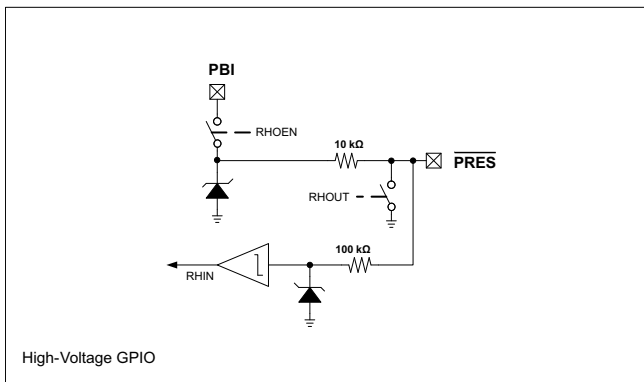

High-Voltage GPIO

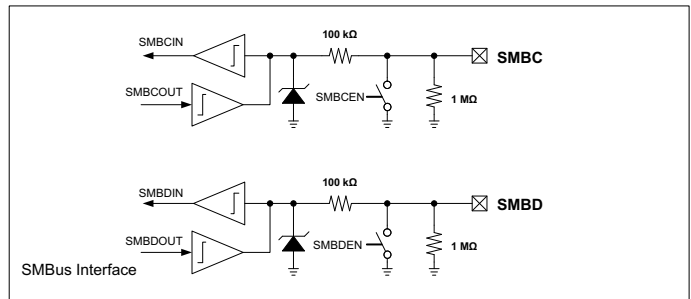

SMBus Interface

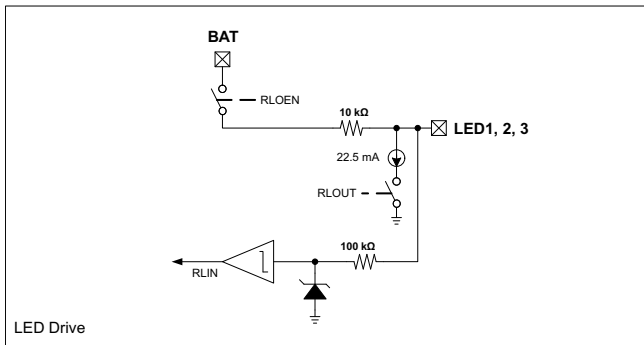

LED Drive

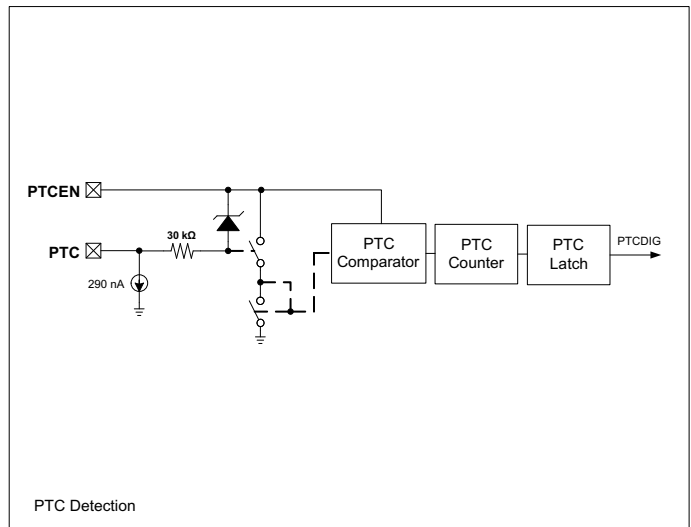

PTC Detection

Figure 2. Pin Equivalent Diagram 2

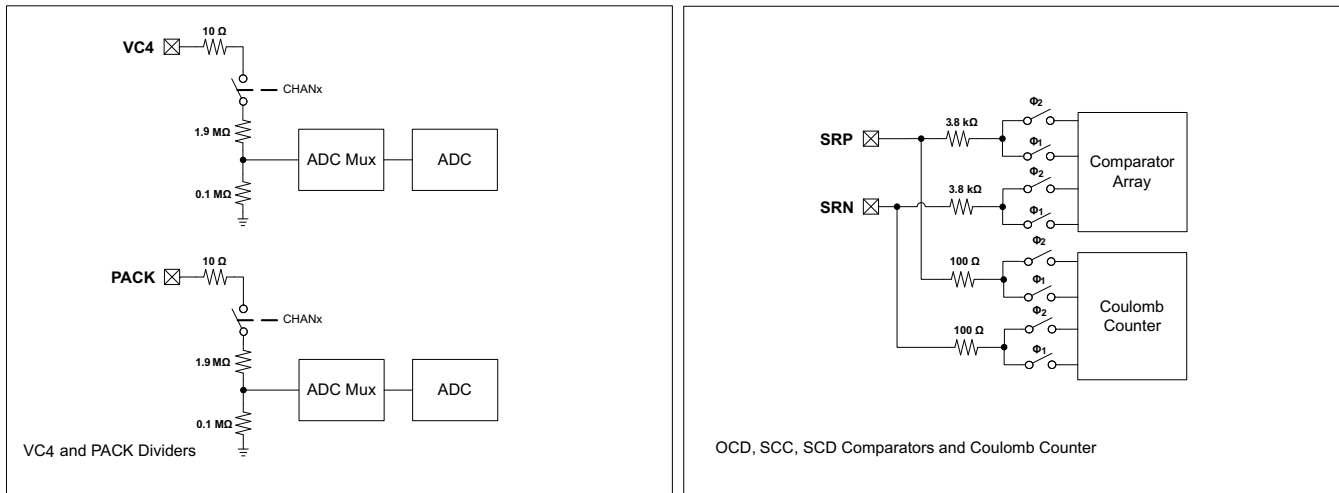

Figure 3. Pin Equivalent Diagram 3

7 Specifications

7.1 Absolute Maximum Ratings

Over-operating free-air temperature range (unless otherwise noted)⁽¹⁾

		MIN	MAX	UNIT
Supply voltage range, V _{CC}	BAT, VCC, PBI	-0.3	30	V
Input voltage range, V _{IN}	PACK, SMBC, SMBD, PRES or SHUTDN, BTP_INT, DISP	-0.3	30	V
	TS1, TS2, TS3, TS4	-0.3	V _{REG} + 0.3	V
	PTC, PTCEN, LEDCNTLA, LEDCNTLB, LEDCNTLC	-0.3	V _{BAT} + 0.3	V
	SRP, SRN	-0.3	0.3	V
	VC4	VC3 - 0.3	VC3 + 8.5, or VSS + 30	V
	VC3	VC2 - 0.3	VC2 + 8.5, or VSS + 30	V
Output voltage range, V _O	VC2	VC1 - 0.3	VC1 + 8.5, or VSS + 30	V
	VC1	VSS - 0.3	VSS + 8.5, or VSS + 30	V
	CHG, DSG	-0.3	32	
	PCHG, FUSE	-0.3	30	V
Maximum VSS current, I _{SS}			50	mA
Storage temperature, T _{STG}		-65	150	°C
Lead temperature (soldering, 10 s), T _{SOLDER}			300	°C

(1) Stresses beyond those listed under *absolute maximum ratings* may cause permanent damage to the device. These are stress ratings only, and functional operation of the device at these or any other conditions beyond those indicated under *recommended operating conditions* is not implied. Exposure to absolute-maximum-rated conditions for extended periods may affect device reliability.

7.2 ESD Ratings

		VALUE	UNIT
V _(ESD)	Electrostatic discharge	Human-body model (HBM), per ANSI/ESDA/JEDEC JS-001 ⁽¹⁾	±2000
		Charged-device model (CDM), per JEDEC specification JESD22-C101 ⁽²⁾	±500

(1) JEDEC document JEP155 states that 500-V HBM allows safe manufacturing with a standard ESD control process.

(2) JEDEC document JEP157 states that 250-V CDM allows safe manufacturing with a standard ESD control process.

7.3 Recommended Operating Conditions

Typical values stated where $T_A = 25^\circ\text{C}$ and $V_{CC} = 14.4\text{ V}$, Min/Max values stated where $T_A = -40^\circ\text{C}$ to 85°C and $V_{CC} = 2.2\text{ V}$ to 26 V (unless otherwise noted)

			MIN	NOM	MAX	UNIT
V_{CC}	Supply voltage	BAT, VCC, PBI	2.2		26	V
$V_{SHUTDOWN-}$	Shutdown voltage	$V_{PACK} < V_{SHUTDOWN-}$	1.8	2.0	2.2	V
$V_{SHUTDOWN+}$	Start-up voltage	$V_{PACK} > V_{SHUTDOWN-} + V_{HYS}$	2.05	2.25	2.45	V
V_{HYS}	Shutdown voltage hysteresis	$V_{SHUTDOWN+} - V_{SHUTDOWN-}$		250		mV
V_{IN}	Input voltage range	PACK, SMBC, SMBD, \overline{PRES} , BTP_IN, \overline{DISP}			26	V
		TS1, TS2, TS3, TS4			V_{REG}	
		PTC, PTCEN, LEDCNTLA, LEDCNTLB, LEDCNTLC			V_{BAT}	
		SRP, SRN	-0.2		0.2	
		VC4	V_{VC3}		$V_{VC3} + 5$	
		VC3	V_{VC2}		$V_{VC2} + 5$	
		VC2	V_{VC1}		$V_{VC1} + 5$	
V_O	Output voltage range	CHG, DSG, PCHG, FUSE			26	V
C_{PBI}	External PBI capacitor		2.2			μF
T_{OPR}	Operating temperature		-40		85	$^\circ\text{C}$

7.4 Thermal Information

THERMAL METRIC ⁽¹⁾		RSM (QFN)	UNIT
		32 PINS	
$R_{\theta JA, \text{High K}}$	Junction-to-ambient thermal resistance	47.4	$^\circ\text{C/W}$
$R_{\theta JC(\text{top})}$	Junction-to-case(top) thermal resistance	40.3	
$R_{\theta JB}$	Junction-to-board thermal resistance	14.7	
Ψ_{JT}	Junction-to-top characterization parameter	0.8	
Ψ_{JB}	Junction-to-board characterization parameter	14.4	
$R_{\theta JC(\text{bottom})}$	Junction-to-case(bottom) thermal resistance	3.8	

(1) For more information about traditional and new thermal metrics, see the *Semiconductor and IC Package Thermal Metrics* application report, [SPRA953](#).

7.5 Electrical Characteristics: Supply Current

Typical values stated where $T_A = 25^\circ\text{C}$ and $V_{CC} = 14.4\text{ V}$, Min/Max values stated where $T_A = -40^\circ\text{C}$ to 85°C and $V_{CC} = 2.2\text{ V}$ to 20 V (unless otherwise noted)

PARAMETER	TEST CONDITIONS	MIN	TYP	MAX	UNIT
I_{NORMAL}	NORMAL mode CHG on, DSG on, no Flash write		336		μA
I_{SLEEP}	SLEEP mode CHG off, DSG on, no SBS communication		75		μA
	CHG off, DSG off, no SBS communication		52		
$I_{SHUTDOWN}$	SHUTDOWN mode		1.6		μA

7.6 Electrical Characteristics: Power Supply Control

Typical values stated where $T_A = 25^\circ\text{C}$ and $V_{CC} = 14.4\text{ V}$, Min/Max values stated where $T_A = -40^\circ\text{C}$ to 85°C and $V_{CC} = 2.2\text{ V}$ to 26 V (unless otherwise noted)

PARAMETER	TEST CONDITIONS	MIN	TYP	MAX	UNIT
$V_{SWITCHOVER-}$	BAT to V_{CC} switchover voltage $V_{BAT} < V_{SWITCHOVER-}$	1.95	2.1	2.2	V

Electrical Characteristics: Power Supply Control (continued)

Typical values stated where $T_A = 25^\circ\text{C}$ and $V_{CC} = 14.4\text{ V}$, Min/Max values stated where $T_A = -40^\circ\text{C}$ to 85°C and $V_{CC} = 2.2\text{ V}$ to 26 V (unless otherwise noted)

PARAMETER		TEST CONDITIONS	MIN	TYP	MAX	UNIT
$V_{\text{SWITCHOVER+}}$	V_{CC} to BAT switchover voltage	$V_{\text{BAT}} > V_{\text{SWITCHOVER-}} + V_{\text{HYS}}$	2.9	3.1	3.25	V
V_{HYS}	Switchover voltage hysteresis	$V_{\text{SWITCHOVER+}} - V_{\text{SWITCHOVER-}}$		1000		mV
I_{LKG}	Input Leakage current	BAT pin, BAT = 0 V, VCC = 25 V, PACK = 25 V			1	μA
		PACK pin, BAT = 25 V, VCC = 0 V, PACK = 0 V			1	
		BAT and PACK terminals, BAT = 0 V, VCC = 0 V, PACK = 0 V, PBI = 25 V			1	
R_{PD}	Internal pulldown resistance	PACK	30	40	50	k Ω

7.7 Electrical Characteristics: AFE Power-On Reset

Typical values stated where $T_A = 25^\circ\text{C}$ and $V_{CC} = 14.4\text{ V}$, Min/Max values stated where $T_A = -40^\circ\text{C}$ to 85°C and $V_{CC} = 2.2\text{ V}$ to 26 V (unless otherwise noted)

PARAMETER		TEST CONDITIONS	MIN	TYP	MAX	UNIT
$V_{\text{REGIT-}}$	Negative-going voltage input	V_{REG}	1.51	1.55	1.59	V
V_{HYS}	Power-on reset hysteresis	$V_{\text{REGIT+}} - V_{\text{REGIT-}}$	70	100	130	mV
t_{RST}	Power-on reset time		200	300	400	μs

7.8 Electrical Characteristics: AFE Watchdog Reset and Wake Timer

Typical values stated where $T_A = 25^\circ\text{C}$ and $V_{CC} = 14.4\text{ V}$, Min/Max values stated where $T_A = -40^\circ\text{C}$ to 85°C and $V_{CC} = 2.2\text{ V}$ to 26 V (unless otherwise noted)

PARAMETER		TEST CONDITIONS	MIN	TYP	MAX	UNIT
t_{WDT}	AFE watchdog timeout	$t_{\text{WDT}} = 500$	372	500	628	ms
		$t_{\text{WDT}} = 1000$	744	1000	1256	
		$t_{\text{WDT}} = 2000$	1488	2000	2512	
		$t_{\text{WDT}} = 4000$	2976	4000	5024	
t_{WAKE}	AFE wake timer	$t_{\text{WAKE}} = 250$	186	250	314	ms
		$t_{\text{WAKE}} = 500$	372	500	628	
		$t_{\text{WAKE}} = 1000$	744	1000	1256	
		$t_{\text{WAKE}} = 512$	1488	2000	2512	
t_{FETOFF}	FET off delay after reset	$t_{\text{FETOFF}} = 512$	409	512	614	ms

7.9 Electrical Characteristics: Current Wake Comparator

Typical values stated where $T_A = 25^\circ\text{C}$ and $V_{CC} = 14.4\text{ V}$, Min/Max values stated where $T_A = -40^\circ\text{C}$ to 85°C and $V_{CC} = 2.2\text{ V}$ to 26 V (unless otherwise noted)

PARAMETER		TEST CONDITIONS	MIN	TYP	MAX	UNIT
V_{WAKE}	Wake voltage threshold	$V_{\text{WAKE}} = \pm 0.625\text{ mV}$	± 0.3	± 0.625	± 0.9	mV
		$V_{\text{WAKE}} = \pm 1.25\text{ mV}$	± 0.6	± 1.25	± 1.8	
		$V_{\text{WAKE}} = \pm 2.5\text{ mV}$	± 1.2	± 2.5	± 3.6	
		$V_{\text{WAKE}} = \pm 5\text{ mV}$	± 2.4	± 5.0	± 7.2	
$V_{\text{WAKE(DRIFT)}}$	Temperature drift of V_{WAKE} accuracy			0.5%		$^\circ\text{C}$

Electrical Characteristics: Current Wake Comparator (continued)

Typical values stated where $T_A = 25^\circ\text{C}$ and $V_{CC} = 14.4\text{ V}$, Min/Max values stated where $T_A = -40^\circ\text{C}$ to 85°C and $V_{CC} = 2.2\text{ V}$ to 26 V (unless otherwise noted)

PARAMETER	TEST CONDITIONS	MIN	TYP	MAX	UNIT
t_{WAKE}	Time from application of current to wake interrupt			700	μs
$t_{\text{WAKE(SU)}}$	Wake comparator startup time		500	1000	μs

7.10 Electrical Characteristics: VC1, VC2, VC3, VC4, BAT, PACK

Typical values stated where $T_A = 25^\circ\text{C}$ and $V_{CC} = 14.4\text{ V}$, Min/Max values stated where $T_A = -40^\circ\text{C}$ to 85°C and $V_{CC} = 2.2\text{ V}$ to 26 V (unless otherwise noted)

PARAMETER	TEST CONDITIONS	MIN	TYP	MAX	UNIT	
K	VC1–VSS, VC2–VC1, VC3–VC2, VC4–VC3	0.1980	0.2000	0.2020	—	
	BAT–VSS, PACK–VSS	0.049	0.050	0.051		
	V_{REF2}	0.490	0.500	0.510		
V_{IN}	VC1–VSS, VC2–VC1, VC3–VC2, VC4–VC3	–0.2		5	V	
	BAT–VSS, PACK–VSS	–0.2		20		
I_{LKG}	VC1, VC2, VC3, VC4, cell balancing off, cell detach detection off, ADC multiplexer off			1	μA	
R_{CB}	Internal cell balance resistance	$R_{\text{DS(ON)}}$ for internal FET switch at $2\text{ V} < V_{\text{DS}} < 4\text{ V}$			200	Ω
I_{CD}	Internal cell detach check current	VCx > VSS + 0.8 V	30	50	70	μA

7.11 Electrical Characteristics: SMBD, SMBC

Typical values stated where $T_A = 25^\circ\text{C}$ and $V_{CC} = 14.4\text{ V}$, Min/Max values stated where $T_A = -40^\circ\text{C}$ to 85°C and $V_{CC} = 2.2\text{ V}$ to 26 V (unless otherwise noted)

PARAMETER	TEST CONDITIONS	MIN	TYP	MAX	UNIT	
V_{IH}	Input voltage high	SMBC, SMBD, $V_{\text{REG}} = 1.8\text{ V}$	1.3		V	
V_{IL}	Input voltage low	SMBC, SMBD, $V_{\text{REG}} = 1.8\text{ V}$		0.8	V	
V_{OL}	Output low voltage	SMBC, SMBD, $V_{\text{REG}} = 1.8\text{ V}$, $I_{\text{OL}} = 1.5\text{ mA}$		0.4	V	
C_{IN}	Input capacitance		5		pF	
I_{LKG}	Input leakage current			1	μA	
R_{PD}	Pulldown resistance		0.7	1.0	1.3	M Ω

7.12 Electrical Characteristics: $\overline{\text{PRES}}$, BTP_INT, $\overline{\text{DISP}}$

Typical values stated where $T_A = 25^\circ\text{C}$ and $V_{CC} = 14.4\text{ V}$, Min/Max values stated where $T_A = -40^\circ\text{C}$ to 85°C and $V_{CC} = 2.2\text{ V}$ to 26 V (unless otherwise noted)

PARAMETER	TEST CONDITIONS	MIN	TYP	MAX	UNIT
V_{IH}	High-level input	1.3			V
V_{IL}	Low-level input			0.55	V
V_{OH}	Output voltage high	$V_{\text{BAT}} > 5.5\text{ V}$, $I_{\text{OH}} = -0\ \mu\text{A}$	3.5		V
		$V_{\text{BAT}} > 5.5\text{ V}$, $I_{\text{OH}} = -10\ \mu\text{A}$	1.8		
V_{OL}	Output voltage low	$I_{\text{OL}} = 1.5\text{ mA}$		0.4	V
C_{IN}	Input capacitance		5		pF
I_{LKG}	Input leakage current			1	μA
R_{O}	Output reverse resistance	Between $\overline{\text{PRES}}$ or BTP_INT or $\overline{\text{DISP}}$ and PBI	8		k Ω

7.13 Electrical Characteristics: LEDCNTLA, LEDCNTLB, LEDCNTLC

Typical values stated where $T_A = 25^\circ\text{C}$ and $V_{CC} = 14.4\text{ V}$, Min/Max values stated where $T_A = -40^\circ\text{C}$ to 85°C and $V_{CC} = 2.2\text{ V}$ to 26 V (unless otherwise noted)

PARAMETER	TEST CONDITIONS	MIN	TYP	MAX	UNIT
V_{IH}	High-level input	1.45			V
V_{IL}	Low-level input			0.55	V
V_{OH}	Output voltage high $V_{BAT} > 3.0\text{ V}$, $I_{OH} = -22.5\text{ mA}$	$V_{BAT} - 1.6$			V
V_{OL}	Output voltage low $I_{OL} = 1.5\text{ mA}$			0.4	V
I_{SC}	High level output current protection	-30	-45	-60	mA
I_{OL}	Low level output current $V_{BAT} > 3.0\text{ V}$, $V_{OH} = 0.4\text{ V}$	15.75	22.5	29.25	mA
$I_{LEDCNTLX}$	Current matching between LEDCNTLX $V_{BAT} = V_{LEDCNTLX} + 2.5\text{ V}$		$\pm 1\%$		
C_{IN}	Input capacitance		20		pF
I_{LKG}	Input leakage current			1	μA
$f_{LEDCNTLX}$	Frequency of LED pattern		124		Hz

7.14 Electrical Characteristics: Coulomb Counter

Typical values stated where $T_A = 25^\circ\text{C}$ and $V_{CC} = 14.4\text{ V}$, Min/Max values stated where $T_A = -40^\circ\text{C}$ to 85°C and $V_{CC} = 2.2\text{ V}$ to 26 V (unless otherwise noted)

PARAMETER	TEST CONDITIONS	MIN	TYP	MAX	UNIT
Input voltage range		-0.1		0.1	V
Full scale range		$-V_{REF1}/10$		$V_{REF1}/10$	V
Integral nonlinearity ⁽¹⁾	16-bit, best fit over input voltage range		± 5.2	± 22.3	LSB
Offset error	16-bit, Post-calibration		± 5	± 10	μV
Offset error drift	15-bit + sign, Post-calibration		0.2	0.3	$\mu\text{V}/^\circ\text{C}$
Gain error	15-bit + sign, over input voltage range		$\pm 0.2\%$	$\pm 0.8\%$	FSR
Gain error drift	15-bit + sign, over input voltage range			150	PPM/ $^\circ\text{C}$
Effective input resistance		2.5			M Ω

(1) $1\text{ LSB} = V_{REF1}/(10 \times 2^N) = 1.215/(10 \times 2^{15}) = 3.71\text{ }\mu\text{V}$

7.15 Electrical Characteristics: CC Digital Filter

Typical values stated where $T_A = 25^\circ\text{C}$ and $V_{CC} = 14.4\text{ V}$, Min/Max values stated where $T_A = -40^\circ\text{C}$ to 85°C and $V_{CC} = 2.2\text{ V}$ to 26 V (unless otherwise noted)

PARAMETER	TEST CONDITIONS	MIN	TYP	MAX	UNIT
Conversion time	Single conversion		250		ms
Effective resolution	Single conversion	15			Bits

7.16 Electrical Characteristics: ADC

Typical values stated where $T_A = 25^\circ\text{C}$ and $V_{CC} = 14.4\text{ V}$, Min/Max values stated where $T_A = -40^\circ\text{C}$ to 85°C and $V_{CC} = 2.2\text{ V}$ to 26 V (unless otherwise noted)

PARAMETER	TEST CONDITIONS	MIN	TYP	MAX	UNIT
Input voltage range	Internal reference (V_{REF1})	-0.2		1	V
	External reference (V_{REG})	-0.2	$0.8 \times V_{REG}$		
Full scale range	$V_{FS} = V_{REF1}$ or V_{REG}	$-V_{FS}$		V_{FS}	V
Integral nonlinearity ⁽¹⁾	16-bit, best fit, -0.1 V to $0.8 \times V_{REF1}$			± 6.6	LSB
	16-bit, best fit, -0.2 V to -0.1 V			± 13.1	

(1) $1\text{ LSB} = V_{REF1}/(2^N) = 1.225/(2^{15}) = 37.4\text{ }\mu\text{V}$ (when $t_{CONV} = 31.25\text{ ms}$)

Electrical Characteristics: ADC (continued)

Typical values stated where $T_A = 25^\circ\text{C}$ and $V_{CC} = 14.4\text{ V}$, Min/Max values stated where $T_A = -40^\circ\text{C}$ to 85°C and $V_{CC} = 2.2\text{ V}$ to 26 V (unless otherwise noted)

PARAMETER	TEST CONDITIONS	MIN	TYP	MAX	UNIT
Offset error ⁽²⁾	16-bit, Post-calibration, $V_{FS} = V_{REF1}$		±67	±157	μV
Offset error drift	16-bit, Post-calibration, $V_{FS} = V_{REF1}$		0.6	3	μV/°C
Gain error	16-bit, -0.1 V to $0.8 \times V_{FS}$		±0.2%	±0.8%	FSR
Gain error drift	16-bit, -0.1 V to $0.8 \times V_{FS}$			150	PPM/°C
Effective input resistance		8			MΩ

(2) For $VC1-VSS$, $VC2-VC1$, $VC3-VC2$, $VC4-VC3$, $VC4-VSS$, $PACK-VSS$, and $V_{REF1}/2$, the offset error is multiplied by $(1/\text{ADC multiplexer scaling factor (K)})$.

7.17 Electrical Characteristics: ADC Digital Filter

Typical values stated where $T_A = 25^\circ\text{C}$ and $V_{CC} = 14.4\text{ V}$, Min/Max values stated where $T_A = -40^\circ\text{C}$ to 85°C and $V_{CC} = 2.2\text{ V}$ to 26 V (unless otherwise noted)

PARAMETER	TEST CONDITIONS	MIN	TYP	MAX	UNIT
Conversion time	Single conversion		31.25		ms
	Single conversion		15.63		
	Single conversion		7.81		
	Single conversion		1.95		
Resolution	No missing codes	16			Bits
Effective resolution	With sign, $t_{CONV} = 31.25\text{ ms}$	14	15		Bits
	With sign, $t_{CONV} = 15.63\text{ ms}$	13	14		
	With sign, $t_{CONV} = 7.81\text{ ms}$	11	12		
	With sign, $t_{CONV} = 1.95\text{ ms}$	9	10		

7.18 Electrical Characteristics: CHG, DSG FET Drive

Typical values stated where $T_A = 25^\circ\text{C}$ and $V_{CC} = 14.4\text{ V}$, Min/Max values stated where $T_A = -40^\circ\text{C}$ to 85°C and $V_{CC} = 2.2\text{ V}$ to 26 V (unless otherwise noted)

PARAMETER	TEST CONDITIONS	MIN	TYP	MAX	UNIT
Output voltage ratio	$\text{Ratio}_{DSG} = (V_{DSG} - V_{BAT})/V_{BAT}$, $2.2\text{ V} < V_{BAT} < 4.92\text{ V}$, $10\text{ M}\Omega$ between PACK and DSG	2.133	2.333	2.433	—
	$\text{Ratio}_{CHG} = (V_{CHG} - V_{BAT})/V_{BAT}$, $2.2\text{ V} < V_{BAT} < 4.92\text{ V}$, $10\text{ M}\Omega$ between BAT and CHG	2.133	2.333	2.433	
$V_{(FETON)}$	Output voltage, CHG and DSG on $V_{DSG(ON)} = V_{DSG} - V_{BAT}$, $V_{BAT} \geq 4.92\text{ V}$, $10\text{ M}\Omega$ between PACK and DSG, $V_{BAT} = 18\text{ V}$	10.5	11.5	12	V
	$V_{CHG(ON)} = V_{CHG} - V_{BAT}$, $V_{BAT} \geq 4.92\text{ V}$, $10\text{ M}\Omega$ between BAT and CHG, $V_{BAT} = 18\text{ V}$	10.5	11.5	12	
$V_{(FETOFF)}$	Output voltage, CHG and DSG off $V_{DSG(OFF)} = V_{DSG} - V_{PACK}$, $10\text{ M}\Omega$ between PACK and DSG	-0.4		0.4	V
	$V_{CHG(OFF)} = V_{CHG} - V_{BAT}$, $10\text{ M}\Omega$ between BAT and CHG	-0.4		0.4	
t_R	Rise time V_{DSG} from 0% to 35% $V_{DSG(ON)(TYP)}$, $V_{BAT} \geq 2.2\text{ V}$, $C_L = 4.7\text{ nF}$ between DSG and PACK, $5.1\text{ k}\Omega$ between DSG and C_L , $10\text{ M}\Omega$ between PACK and DSG		200	500	μs
	V_{CHG} from 0% to 35% $V_{CHG(ON)(TYP)}$, $V_{BAT} \geq 2.2\text{ V}$, $C_L = 4.7\text{ nF}$ between CHG and BAT, $5.1\text{ k}\Omega$ between CHG and C_L , $10\text{ M}\Omega$ between BAT and CHG		200	500	
t_F	Fall time V_{DSG} from $V_{DSG(ON)(TYP)}$ to 1 V , $V_{BAT} \geq 2.2\text{ V}$, $C_L = 4.7\text{ nF}$ between DSG and PACK, $5.1\text{ k}\Omega$ between DSG and C_L , $10\text{ M}\Omega$ between PACK and DSG		40	300	μs
	V_{CHG} from $V_{CHG(ON)(TYP)}$ to 1 V , $V_{BAT} \geq 2.2\text{ V}$, $C_L = 4.7\text{ nF}$ between CHG and BAT, $5.1\text{ k}\Omega$ between CHG and C_L , $10\text{ M}\Omega$ between BAT and CHG		40	200	

7.19 Electrical Characteristics: PCHG FET Drive

Typical values stated where $T_A = 25^\circ\text{C}$ and $V_{CC} = 14.4\text{ V}$, Min/Max values stated where $T_A = -40^\circ\text{C}$ to 85°C and $V_{CC} = 2.2\text{ V}$ to 26 V (unless otherwise noted)

PARAMETER		TEST CONDITIONS	MIN	TYP	MAX	UNIT
$V_{(\text{FETON})}$	Output voltage, PCHG on	$V_{\text{PCHG(ON)}} = V_{\text{VCC}} - V_{\text{PCHG}}$, 10 M Ω between V_{CC} and PCHG	6	7	8	V
$V_{(\text{FETOFF})}$	Output voltage, PCHG off	$V_{\text{PCHG(OFF)}} = V_{\text{VCC}} - V_{\text{PCHG}}$, 10 M Ω between V_{CC} and PCHG	-0.4		0.4	V
t_R	Rise time	V_{PCHG} from 10% to 90% $V_{\text{PCHG(ON)(TYP)}}$, $V_{\text{CC}} \geq 8\text{ V}$, $C_L = 4.7\text{ nF}$ between PCHG and V_{CC} , 5.1 k Ω between PCHG and C_L , 10 M Ω between V_{CC} and CHG		40	200	μs
t_F	Fall time	V_{PCHG} from 90% to 10% $V_{\text{PCHG(ON)(TYP)}}$, $V_{\text{CC}} \geq 8\text{ V}$, $C_L = 4.7\text{ nF}$ between PCHG and V_{CC} , 5.1 k Ω between PCHG and C_L , 10 M Ω between V_{CC} and CHG		40	200	μs

7.20 Electrical Characteristics: FUSE Drive

Typical values stated where $T_A = 25^\circ\text{C}$ and $V_{CC} = 14.4\text{ V}$, Min/Max values stated where $T_A = -40^\circ\text{C}$ to 85°C and $V_{CC} = 2.2\text{ V}$ to 26 V (unless otherwise noted)

PARAMETER		TEST CONDITIONS	MIN	TYP	MAX	UNIT
V_{OH}	Output voltage high	$V_{\text{BAT}} \geq 8\text{ V}$, $C_L = 1\text{ nF}$, $I_{\text{AFE FUSE}} = 0\text{ }\mu\text{A}$	6	7	8.65	V
		$V_{\text{BAT}} < 8\text{ V}$, $C_L = 1\text{ nF}$, $I_{\text{AFE FUSE}} = 0\text{ }\mu\text{A}$	$V_{\text{BAT}} - 0.1$		V_{BAT}	
V_{IH}	High-level input		1.5	2.0	2.5	V
$I_{\text{AFE FUSE(PU)}}$	Internal pullup current	$V_{\text{BAT}} \geq 8\text{ V}$, $V_{\text{AFE FUSE}} = \text{VSS}$		150	330	nA
$R_{\text{AFE FUSE}}$	Output impedance		2	2.6	3.2	k Ω
C_{IN}	Input capacitance			5		pF
t_{DELAY}	Fuse trip detection delay		128		256	μs
t_{RISE}	Fuse output rise time	$V_{\text{BAT}} \geq 8\text{ V}$, $C_L = 1\text{ nF}$, $V_{\text{OH}} = 0\text{ V}$ to 5 V		5	20	μs

7.21 Electrical Characteristics: Internal Temperature Sensor

Typical values stated where $T_A = 25^\circ\text{C}$ and $V_{CC} = 14.4\text{ V}$, Min/Max values stated where $T_A = -40^\circ\text{C}$ to 85°C and $V_{CC} = 2.2\text{ V}$ to 26 V (unless otherwise noted)

PARAMETER		TEST CONDITIONS	MIN	TYP	MAX	UNIT
V_{TEMP}	Internal temperature sensor voltage drift	$V_{\text{TEMP P}}$	-1.9	-2.0	-2.1	mV/ $^\circ\text{C}$
		$V_{\text{TEMP P}} - V_{\text{TEMP N}}$, assured by design	0.177	0.178	0.179	

7.22 Electrical Characteristics: TS1, TS2, TS3, TS4

Typical values stated where $T_A = 25^\circ\text{C}$ and $V_{CC} = 14.4\text{ V}$, Min/Max values stated where $T_A = -40^\circ\text{C}$ to 85°C and $V_{CC} = 2.2\text{ V}$ to 26 V (unless otherwise noted)

PARAMETER		TEST CONDITIONS	MIN	TYP	MAX	UNIT
V_{IN}	Input voltage range	TS1, TS2, TS3, TS4, $V_{\text{BIAS}} = V_{\text{REF1}}$	-0.2	$0.8 \times V_{\text{REF1}}$		V
		TS1, TS2, TS3, TS4, $V_{\text{BIAS}} = V_{\text{REG}}$	-0.2	$0.8 \times V_{\text{REG}}$		
$R_{\text{NTC(PU)}}$	Internal pullup resistance	TS1, TS2, TS3, TS4	14.4	18	21.6	k Ω
$R_{\text{NTC(DRIFT)}}$	Resistance drift over temperature	TS1, TS2, TS3, TS4	-360	-280	-200	PPM/ $^\circ\text{C}$

7.23 Electrical Characteristics: PTC, PTCEN

Typical values stated where $T_A = 25^\circ\text{C}$ and $V_{CC} = 14.4\text{ V}$, Min/Max values stated where $T_A = -40^\circ\text{C}$ to 85°C and $V_{CC} = 2.2\text{ V}$ to 26 V (unless otherwise noted)

PARAMETER	TEST CONDITIONS	MIN	TYP	MAX	UNIT
$R_{\text{PTC(TRIP)}}$ PTC trip resistance		1.2	2.5	3.95	$\text{M}\Omega$
$V_{\text{PTC(TRIP)}}$ PTC trip voltage	$V_{\text{PTC(TRIP)}} = V_{\text{PTCEN}} - V_{\text{PTC}}$	200	500	890	mV
I_{PTC} Internal PTC current bias	$T_A = -40^\circ\text{C}$ to 110°C	200	290	350	nA
$t_{\text{PTC(DELAY)}}$ PTC delay time	$T_A = -40^\circ\text{C}$ to 110°C	40	80	145	ms

7.24 Electrical Characteristics: Internal 1.8-V LDO

Typical values stated where $T_A = 25^\circ\text{C}$ and $V_{CC} = 14.4\text{ V}$, Min/Max values stated where $T_A = -40^\circ\text{C}$ to 85°C and $V_{CC} = 2.2\text{ V}$ to 26 V (unless otherwise noted)

PARAMETER	TEST CONDITIONS	MIN	TYP	MAX	UNIT
V_{REG} Regulator voltage		1.6	1.8	2.0	V
$\Delta V_{\text{O(TEMP)}}$ Regulator output over temperature	$\Delta V_{\text{REG}}/\Delta T_A$, $I_{\text{REG}} = 10\text{ mA}$		$\pm 0.25\%$		
$\Delta V_{\text{O(LINE)}}$ Line regulation	$\Delta V_{\text{REG}}/\Delta V_{\text{BAT}}$, $V_{\text{BAT}} = 10\text{ mA}$	-0.6%		0.5%	
$\Delta V_{\text{O(LOAD)}}$ Load regulation	$\Delta V_{\text{REG}}/\Delta I_{\text{REG}}$, $I_{\text{REG}} = 0\text{ mA}$ to 10 mA	-1.5%		1.5%	
I_{REG} Regulator output current limit	$V_{\text{REG}} = 0.9 \times V_{\text{REG(NOM)}}$, $V_{\text{IN}} > 2.2\text{ V}$	20			mA
I_{SC} Regulator short-circuit current limit	$V_{\text{REG}} = 0 \times V_{\text{REG(NOM)}}$	25	40	55	mA
PSRR_{REG} Power supply rejection ratio	$\Delta V_{\text{BAT}}/\Delta V_{\text{REG}}$, $I_{\text{REG}} = 10\text{ mA}$, $V_{\text{IN}} > 2.5\text{ V}$, $f = 10\text{ Hz}$		40		dB
V_{SLEW} Slew rate enhancement voltage threshold	V_{REG}	1.58	1.65		V

7.25 Electrical Characteristics: High-Frequency Oscillator

Typical values stated where $T_A = 25^\circ\text{C}$ and $V_{CC} = 14.4\text{ V}$, Min/Max values stated where $T_A = -40^\circ\text{C}$ to 85°C and $V_{CC} = 2.2\text{ V}$ to 26 V (unless otherwise noted)

PARAMETER	TEST CONDITIONS	MIN	TYP	MAX	UNIT
f_{HFO} Operating frequency			16.78		MHz
$f_{\text{HFO(ERR)}}$ Frequency error	$T_A = -20^\circ\text{C}$ to 70°C , includes frequency drift	-2.5%	$\pm 0.25\%$	2.5%	
	$T_A = -40^\circ\text{C}$ to 85°C , includes frequency drift	-3.5%	$\pm 0.25\%$	3.5%	
$t_{\text{HFO(SU)}}$ Start-up time	$T_A = -20^\circ\text{C}$ to 85°C , oscillator frequency within $\pm 3\%$ of nominal			4	ms
	oscillator frequency within $\pm 3\%$ of nominal			100	μs

7.26 Electrical Characteristics: Low-Frequency Oscillator

Typical values stated where $T_A = 25^\circ\text{C}$ and $V_{CC} = 14.4\text{ V}$, Min/Max values stated where $T_A = -40^\circ\text{C}$ to 85°C and $V_{CC} = 2.2\text{ V}$ to 26 V (unless otherwise noted)

PARAMETER	TEST CONDITIONS	MIN	TYP	MAX	UNIT
f_{LFO} Operating frequency			262.144		kHz
$f_{\text{LFO(ERR)}}$ Frequency error	$T_A = -20^\circ\text{C}$ to 70°C , includes frequency drift	-1.5%	$\pm 0.25\%$	1.5%	
	$T_A = -40^\circ\text{C}$ to 85°C , includes frequency drift	-2.5	± 0.25	2.5	
$f_{\text{LFO(FAIL)}}$ Failure detection frequency		30	80	100	kHz

7.27 Electrical Characteristics: Voltage Reference 1

Typical values stated where $T_A = 25^\circ\text{C}$ and $V_{CC} = 14.4\text{ V}$, Min/Max values stated where $T_A = -40^\circ\text{C}$ to 85°C and $V_{CC} = 2.2\text{ V}$ to 26 V (unless otherwise noted)

PARAMETER		TEST CONDITIONS	MIN	TYP	MAX	UNIT
V_{REF1}	Internal reference voltage	$T_A = 25^\circ\text{C}$, after trim	1.21	1.215	1.22	V
$V_{REF1(DRIFT)}$	Internal reference voltage drift	$T_A = 0^\circ\text{C}$ to 60°C , after trim		± 50		PPM/ $^\circ\text{C}$
		$T_A = -40^\circ\text{C}$ to 85°C , after trim		± 80		

7.28 Electrical Characteristics: Voltage Reference 2

Typical values stated where $T_A = 25^\circ\text{C}$ and $V_{CC} = 14.4\text{ V}$, Min/Max values stated where $T_A = -40^\circ\text{C}$ to 85°C and $V_{CC} = 2.2\text{ V}$ to 26 V (unless otherwise noted)

PARAMETER		TEST CONDITIONS	MIN	TYP	MAX	UNIT
V_{REF2}	Internal reference voltage	$T_A = 25^\circ\text{C}$, after trim	1.22	1.225	1.23	V
$V_{REF2(DRIFT)}$	Internal reference voltage drift	$T_A = 0^\circ\text{C}$ to 60°C , after trim		± 50		PPM/ $^\circ\text{C}$
		$T_A = -40^\circ\text{C}$ to 85°C , after trim		± 80		

7.29 Electrical Characteristics: Instruction Flash

Typical values stated where $T_A = 25^\circ\text{C}$ and $V_{CC} = 14.4\text{ V}$, Min/Max values stated where $T_A = -40^\circ\text{C}$ to 85°C and $V_{CC} = 2.2\text{ V}$ to 26 V (unless otherwise noted)

PARAMETER		TEST CONDITIONS	MIN	TYP	MAX	UNIT
	Data retention		10			Years
	Flash programming write cycles		1000			Cycles
$t_{PROGWORD}$	Word programming time	$T_A = -40^\circ\text{C}$ to 85°C			40	μs
$t_{MASSERASE}$	Mass-erase time	$T_A = -40^\circ\text{C}$ to 85°C			40	ms
$t_{PAGEERASE}$	Page-erase time	$T_A = -40^\circ\text{C}$ to 85°C			40	ms
$I_{FLASHREAD}$	Flash-read current	$T_A = -40^\circ\text{C}$ to 85°C			2	mA
$I_{FLASHWRITE}$	Flash-write current	$T_A = -40^\circ\text{C}$ to 85°C			5	mA
$I_{FLASHERASE}$	Flash-erase current	$T_A = -40^\circ\text{C}$ to 85°C			15	mA

7.30 Electrical Characteristics: Data Flash

Typical values stated where $T_A = 25^\circ\text{C}$ and $V_{CC} = 14.4\text{ V}$, Min/Max values stated where $T_A = -40^\circ\text{C}$ to 85°C and $V_{CC} = 2.2\text{ V}$ to 26 V (unless otherwise noted)

PARAMETER		TEST CONDITIONS	MIN	TYP	MAX	UNIT
	Data retention		10			Years
	Flash programming write cycles		20000			Cycles
$t_{PROGWORD}$	Word programming time	$T_A = -40^\circ\text{C}$ to 85°C			40	μs
$t_{MASSERASE}$	Mass-erase time	$T_A = -40^\circ\text{C}$ to 85°C			40	ms
$t_{PAGEERASE}$	Page-erase time	$T_A = -40^\circ\text{C}$ to 85°C			40	ms
$I_{FLASHREAD}$	Flash-read current	$T_A = -40^\circ\text{C}$ to 85°C			1	mA
$I_{FLASHWRITE}$	Flash-write current	$T_A = -40^\circ\text{C}$ to 85°C			5	mA
$I_{FLASHERASE}$	Flash-erase current	$T_A = -40^\circ\text{C}$ to 85°C			15	mA

7.31 Electrical Characteristics: OCD, SCC, SCD1, SCD2 Current Protection Thresholds

Typical values stated where $T_A = 25^\circ\text{C}$ and $V_{CC} = 14.4\text{ V}$, Min/Max values stated where $T_A = -40^\circ\text{C}$ to 85°C and $V_{CC} = 2.2\text{ V}$ to 26 V (unless otherwise noted)

PARAMETER		TEST CONDITIONS	MIN	TYP	MAX	UNIT
V_{OCD}	OCD detection threshold voltage range	$V_{\text{OCD}} = V_{\text{SRP}} - V_{\text{SRN}}$, AFE PROTECTION CONTROL[RSNS] = 1	-16.6		-100	mV
		$V_{\text{OCD}} = V_{\text{SRP}} - V_{\text{SRN}}$, AFE PROTECTION CONTROL[RSNS] = 0	-8.3		-50	
ΔV_{OCD}	OCD detection threshold voltage program step	$V_{\text{OCD}} = V_{\text{SRP}} - V_{\text{SRN}}$, AFE PROTECTION CONTROL[RSNS] = 1		-5.56		mV
		$V_{\text{OCD}} = V_{\text{SRP}} - V_{\text{SRN}}$, AFE PROTECTION CONTROL[RSNS] = 0		-2.78		
V_{SCC}	SCC detection threshold voltage range	$V_{\text{SCC}} = V_{\text{SRP}} - V_{\text{SRN}}$, AFE PROTECTION CONTROL[RSNS] = 1	44.4		200	mV
		$V_{\text{SCC}} = V_{\text{SRP}} - V_{\text{SRN}}$, AFE PROTECTION CONTROL[RSNS] = 0	22.2		100	
ΔV_{SCC}	SCC detection threshold voltage program step	$V_{\text{SCC}} = V_{\text{SRP}} - V_{\text{SRN}}$, AFE PROTECTION CONTROL[RSNS] = 1		22.2		mV
		$V_{\text{SCC}} = V_{\text{SRP}} - V_{\text{SRN}}$, AFE PROTECTION CONTROL[RSNS] = 0		11.1		
V_{SCD1}	SCD1 detection threshold voltage range	$V_{\text{SCD1}} = V_{\text{SRP}} - V_{\text{SRN}}$, AFE PROTECTION CONTROL[RSNS] = 1	-44.4		-200	mV
		$V_{\text{SCD1}} = V_{\text{SRP}} - V_{\text{SRN}}$, AFE PROTECTION CONTROL[RSNS] = 0	-22.2		-100	
ΔV_{SCD1}	SCD1 detection threshold voltage program step	$V_{\text{SCD1}} = V_{\text{SRP}} - V_{\text{SRN}}$, AFE PROTECTION CONTROL[RSNS] = 1		-22.2		mV
		$V_{\text{SCD1}} = V_{\text{SRP}} - V_{\text{SRN}}$, AFE PROTECTION CONTROL[RSNS] = 0		-11.1		
V_{SCD2}	SCD2 detection threshold voltage range	$V_{\text{SCD2}} = V_{\text{SRP}} - V_{\text{SRN}}$, AFE PROTECTION CONTROL[RSNS] = 1	-44.4		-200	mV
		$V_{\text{SCD2}} = V_{\text{SRP}} - V_{\text{SRN}}$, AFE PROTECTION CONTROL[RSNS] = 0	-22.2		-100	
ΔV_{SCD2}	SCD2 detection threshold voltage program step	$V_{\text{SCD2}} = V_{\text{SRP}} - V_{\text{SRN}}$, AFE PROTECTION CONTROL[RSNS] = 1		-22.2		mV
		$V_{\text{SCD2}} = V_{\text{SRP}} - V_{\text{SRN}}$, AFE PROTECTION CONTROL[RSNS] = 0		-11.1		
V_{OFFSET}	OCD, SCC, and SCDx offset error	Post-trim	-2.5		2.5	mV
V_{SCALE}	OCD, SCC, and SCDx scale error	No trim	-10%		10%	—
		Post-trim	-5%		5%	

7.32 Timing Requirements: OCD, SCC, SCD1, SCD2 Current Protection Timing

Typical values stated where $T_A = 25^\circ\text{C}$ and $V_{CC} = 14.4\text{ V}$, Min/Max values stated where $T_A = -40^\circ\text{C}$ to 85°C and $V_{CC} = 2.2\text{ V}$ to 26 V (unless otherwise noted)

		MIN	NOM	MAX	UNIT
t_{OCD}	OCD detection delay time	1		31	ms
Δt_{OCD}	OCD detection delay time program step		2		ms
t_{SCC}	SCC detection delay time	0		915	μs
Δt_{SCC}	SCC detection delay time program step		61		μs
t_{SCD1}	SCD1 detection delay time	AFE PROTECTION CONTROL[SCDDx2] = 0	0	915	μs
		AFE PROTECTION CONTROL[SCDDx2] = 1	0	1850	

Timing Requirements: OCD, SCC, SCD1, SCD2 Current Protection Timing (continued)

Typical values stated where $T_A = 25^\circ\text{C}$ and $V_{CC} = 14.4\text{ V}$, Min/Max values stated where $T_A = -40^\circ\text{C}$ to 85°C and $V_{CC} = 2.2\text{ V}$ to 26 V (unless otherwise noted)

			MIN	NOM	MAX	UNIT
Δt_{SCD1}	SCD1 detection delay time program step	AFE PROTECTION CONTROL[SCDDx2] = 0	61			μs
		AFE PROTECTION CONTROL[SCDDx2] = 1	121			
t_{SCD2}	SCD2 detection delay time	AFE PROTECTION CONTROL[SCDDx2] = 0	0		458	μs
		AFE PROTECTION CONTROL[SCDDx2] = 1	0		915	
Δt_{SCD2}	SCD2 detection delay time program step	AFE PROTECTION CONTROL[SCDDx2] = 0	30.5			μs
		AFE PROTECTION CONTROL[SCDDx2] = 1	61			
t_{DETECT}	Current fault detect time	$V_{\text{SRP}} - V_{\text{SRN}} = V_T - 3\text{ mV}$ for OCD, SCD1, and SC2, $V_{\text{SRP}} - V_{\text{SRN}} = V_T + 3\text{ mV}$ for SCC			160	μs
t_{ACC}	Current fault delay time accuracy	Max delay setting	-10%		10%	

7.33 Timing Requirements: SMBus

Typical values stated where $T_A = 25^\circ\text{C}$ and $V_{CC} = 14.4\text{ V}$, Min/Max values stated where $T_A = -40^\circ\text{C}$ to 85°C and $V_{CC} = 2.2\text{ V}$ to 26 V (unless otherwise noted)

			MIN	NOM	MAX	UNIT
f_{SMB}	SMBus operating frequency	SLAVE mode, SMBC 50% duty cycle	10		100	kHz
f_{MAS}	SMBus master clock frequency	MASTER mode, no clock low slave extend	51.2			kHz
t_{BUF}	Bus free time between start and stop		4.7			μs
$t_{\text{HD(START)}}$	Hold time after (repeated) start		4.0			μs
$t_{\text{SU(START)}}$	Repeated start setup time		4.7			μs
$t_{\text{SU(STOP)}}$	Stop setup time		4.0			μs
$t_{\text{HD(DATA)}}$	Data hold time		300			ns
$t_{\text{SU(DATA)}}$	Data setup time		250			ns
t_{TIMEOUT}	Error signal detect time		25		35	ms
t_{LOW}	Clock low period		4.7			μs
t_{HIGH}	Clock high period		4.0		50	μs
t_{R}	Clock rise time	10% to 90%			1000	ns
t_{F}	Clock fall time	90% to 10%			300	ns
$t_{\text{LOW(SEXT)}}$	Cumulative clock low slave extend time				25	ms
$t_{\text{LOW(MEXT)}}$	Cumulative clock low master extend time				10	ms

7.34 Timing Requirements: SMBus XL

Typical values stated where $T_A = 25^\circ\text{C}$ and $V_{CC} = 14.4\text{ V}$, Min/Max values stated where $T_A = -40^\circ\text{C}$ to 85°C and $V_{CC} = 2.2\text{ V}$ to 26 V (unless otherwise noted)

			MIN	NOM	MAX	UNIT
f_{SMBXL}	SMBus XL operating frequency	SLAVE mode	40		400	kHz
t_{BUF}	Bus free time between start and stop		4.7			μs
$t_{\text{HD(START)}}$	Hold time after (repeated) start		4.0			μs

Timing Requirements: SMBus XL (continued)

Typical values stated where $T_A = 25^\circ\text{C}$ and $V_{CC} = 14.4\text{ V}$, Min/Max values stated where $T_A = -40^\circ\text{C}$ to 85°C and $V_{CC} = 2.2\text{ V}$ to 26 V (unless otherwise noted)

		MIN	NOM	MAX	UNIT
$t_{\text{SU(START)}}$	Repeated start setup time	4.7			μs
$t_{\text{SU(STOP)}}$	Stop setup time	4.0			μs
t_{TIMEOUT}	Error signal detect time	5		20	ms
t_{LOW}	Clock low period			20	μs
t_{HIGH}	Clock high period			20	μs

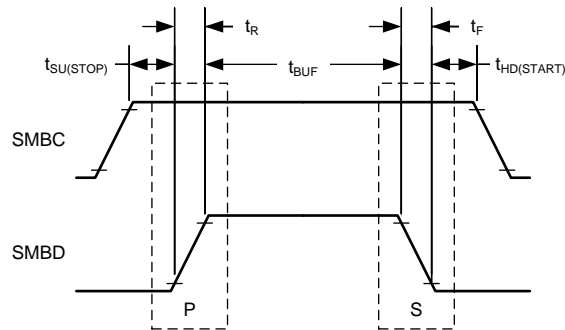

Start and Stop Condition

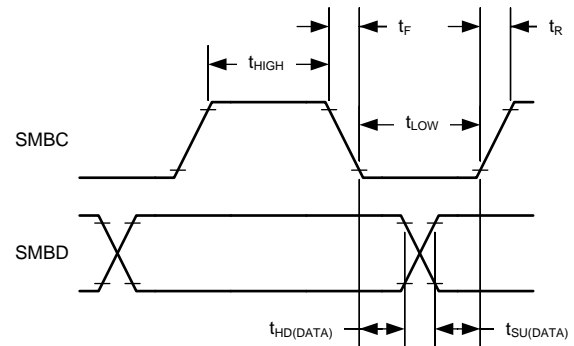

Wait and Hold Condition

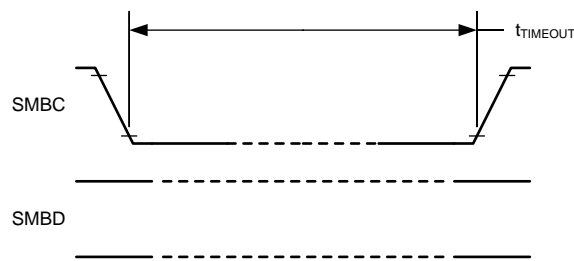

Timeout Condition

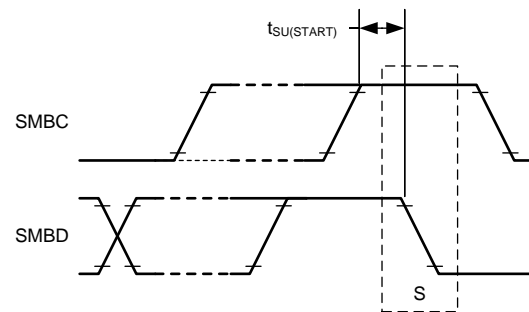

Repeated Start Condition

Figure 4. SMBus Timing Diagram

7.35 Typical Characteristics

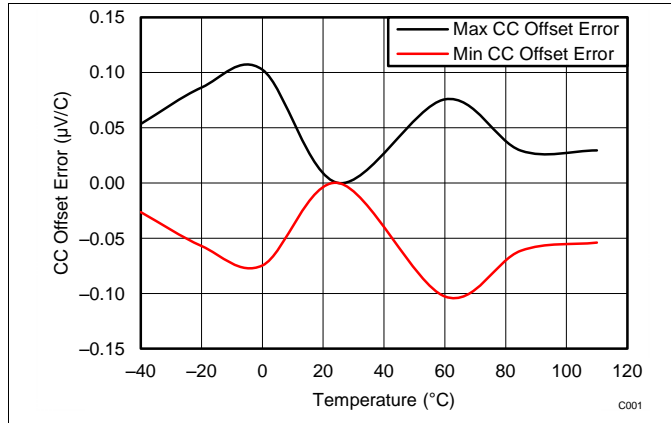

Figure 5. CC Offset Error vs. Temperature

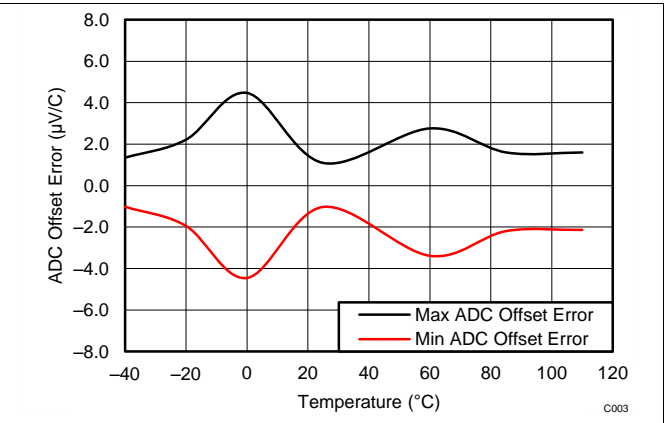

Figure 6. ADC Offset Error vs. Temperature

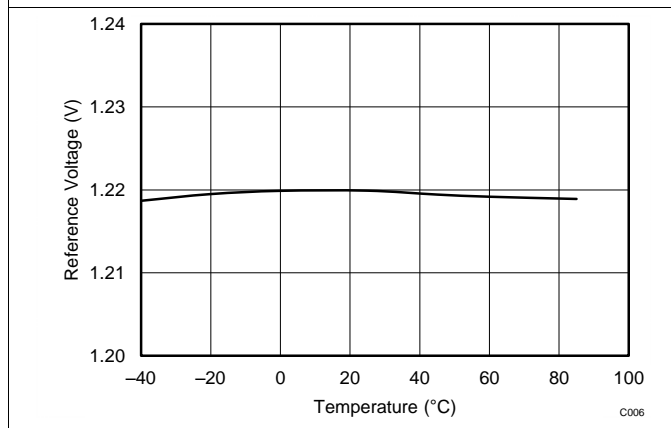

Figure 7. Reference Voltage vs. Temperature

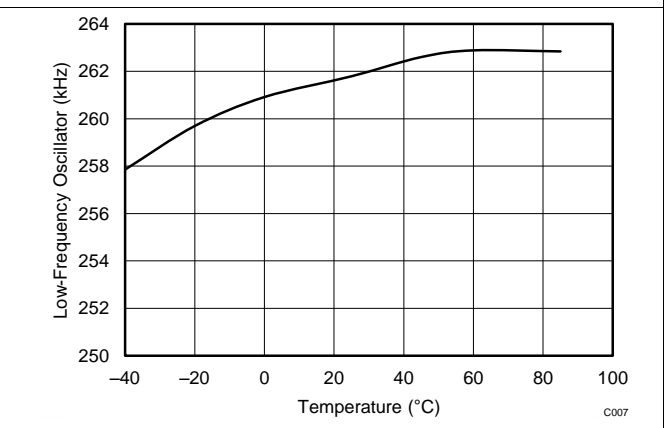

Figure 8. Low-Frequency Oscillator vs. Temperature

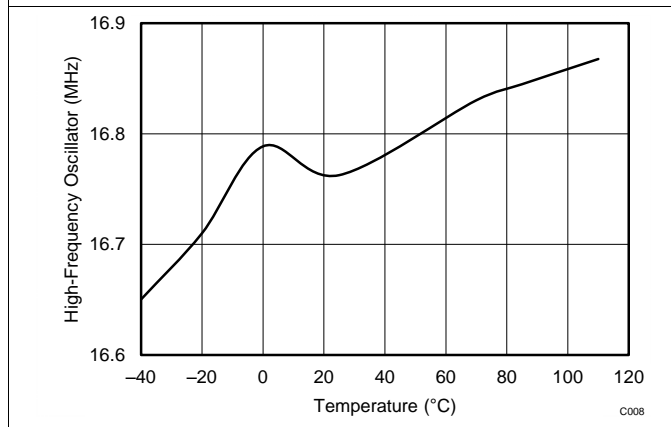
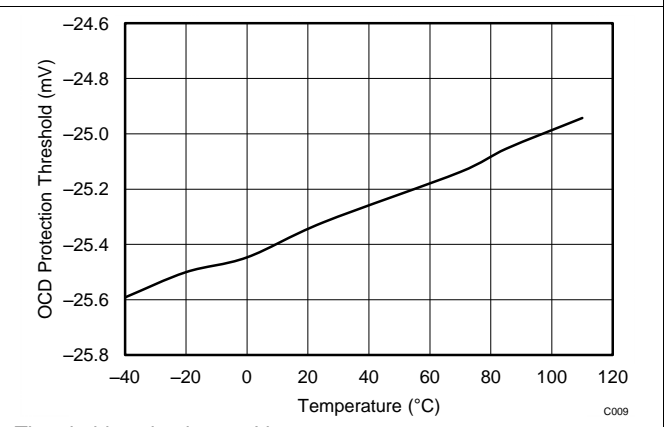

Figure 9. High-Frequency Oscillator vs. Temperature



Threshold setting is 25 mV.

Figure 10. Overcurrent Discharge Protection Threshold vs. Temperature

Typical Characteristics (continued)

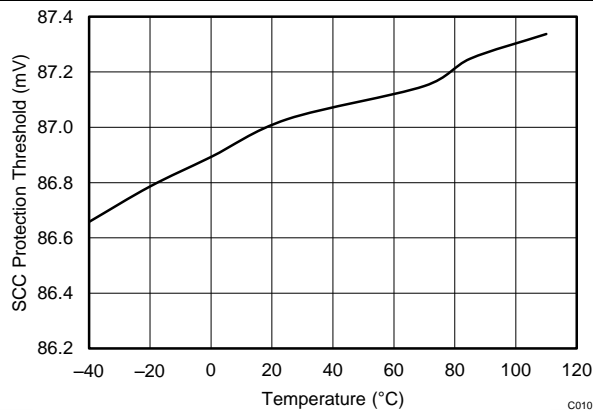

Threshold setting is 25 mV.

Figure 11. Short Circuit Charge Protection Threshold vs. Temperature

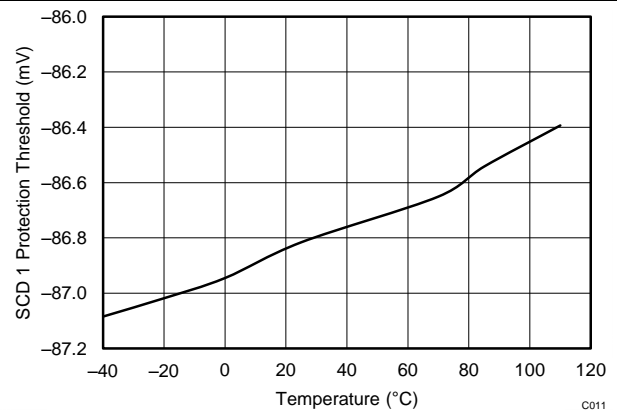

Threshold setting is -88.85 mV.

Figure 12. Short Circuit Discharge 1 Protection Threshold vs. Temperature

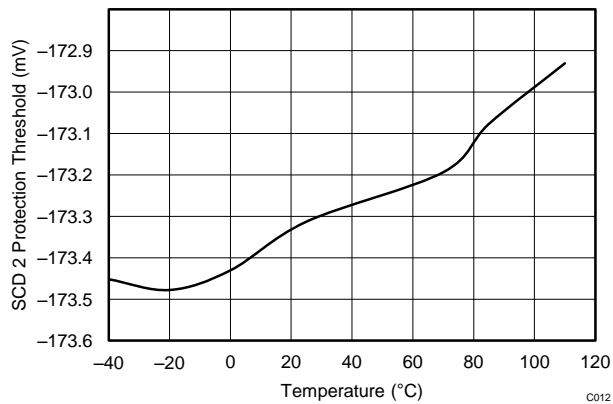

Threshold setting is -177.7 mV.

Figure 13. Short Circuit Discharge 2 Protection Threshold vs. Temperature

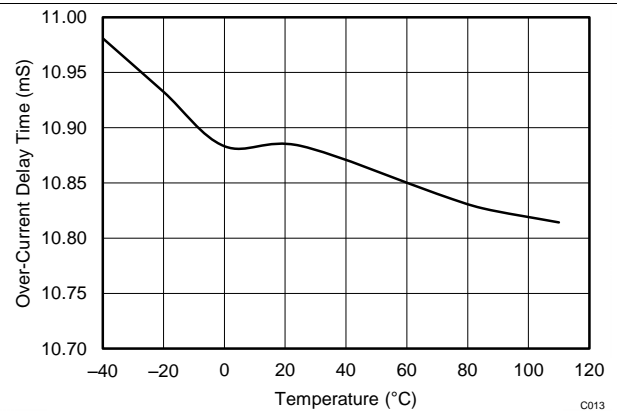

Threshold setting is 11 ms.

Figure 14. Overcurrent Delay Time vs. Temperature

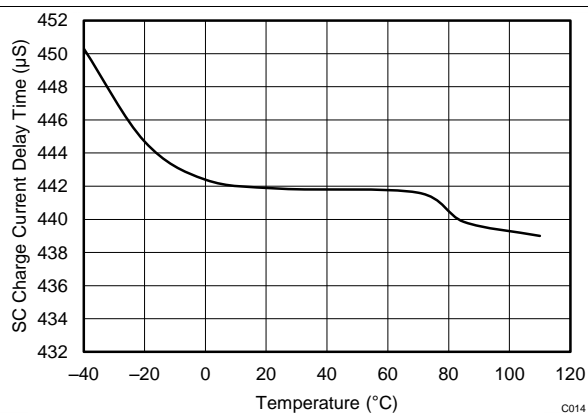

Threshold setting is 465 µs.

Figure 15. Short Circuit Charge Current Delay Time vs. Temperature

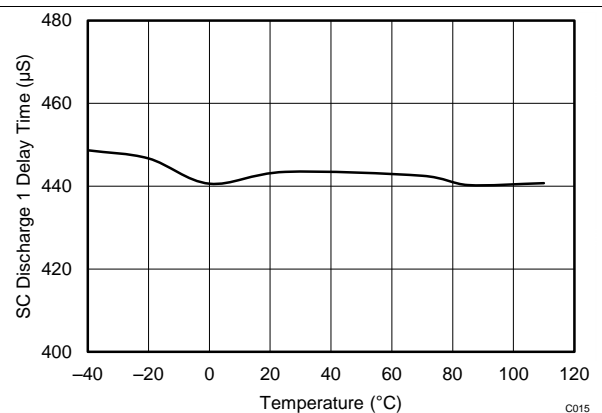

Threshold setting is 465 µs (including internal delay).

Figure 16. Short Circuit Discharge 1 Delay Time vs. Temperature

Typical Characteristics (continued)

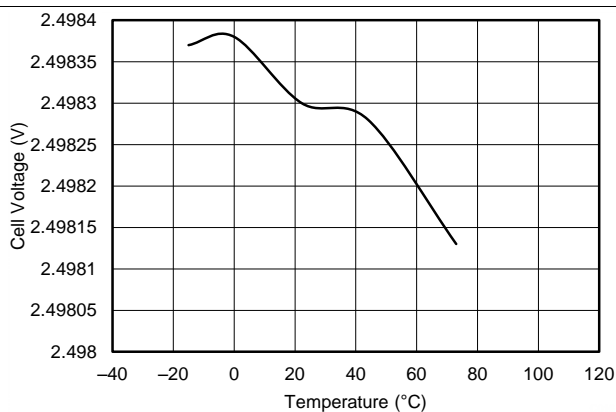
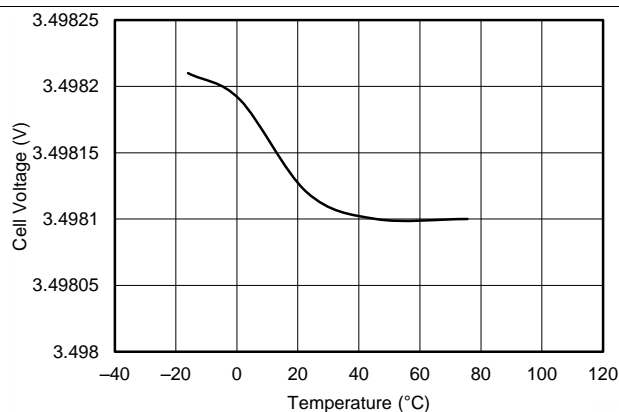
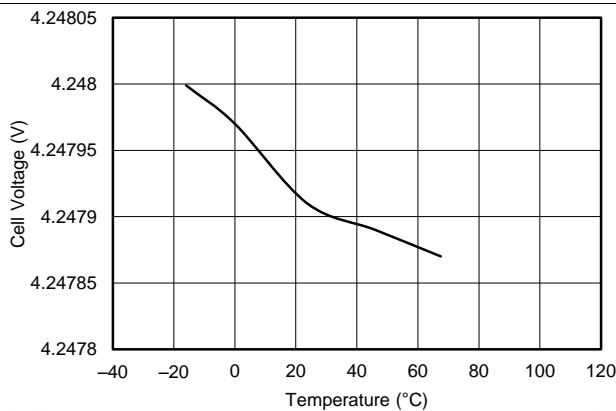

Figure 17. V_{CELL} Measurement at 2.5-V vs. Temperature



This is the V_{CELL} average for single cell.

Figure 18. V_{CELL} Measurement at 3.5-V vs. Temperature



This is the V_{CELL} average for single cell.

Figure 19. V_{CELL} Measurement at 4.25-V vs. Temperature

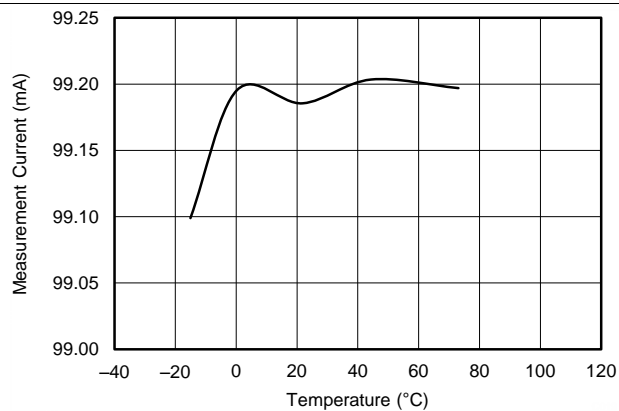

$I_{SET} = 100 \text{ mA}$

Figure 20. I measured vs. Temperature

8 Detailed Description

8.1 Overview

The bq40z50-R1 device, incorporating patented Impedance Track™ technology, provides cell balancing while charging or at rest. This fully integrated, single-chip, pack-based solution provides a rich array of features for gas gauging, protection, and authentication for 1-series, 2-series, 3-series, and 4-series cell Li-Ion and Li-Polymer battery packs, including a diagnostic lifetime data monitor and black box recorder.

8.2 Functional Block Diagram

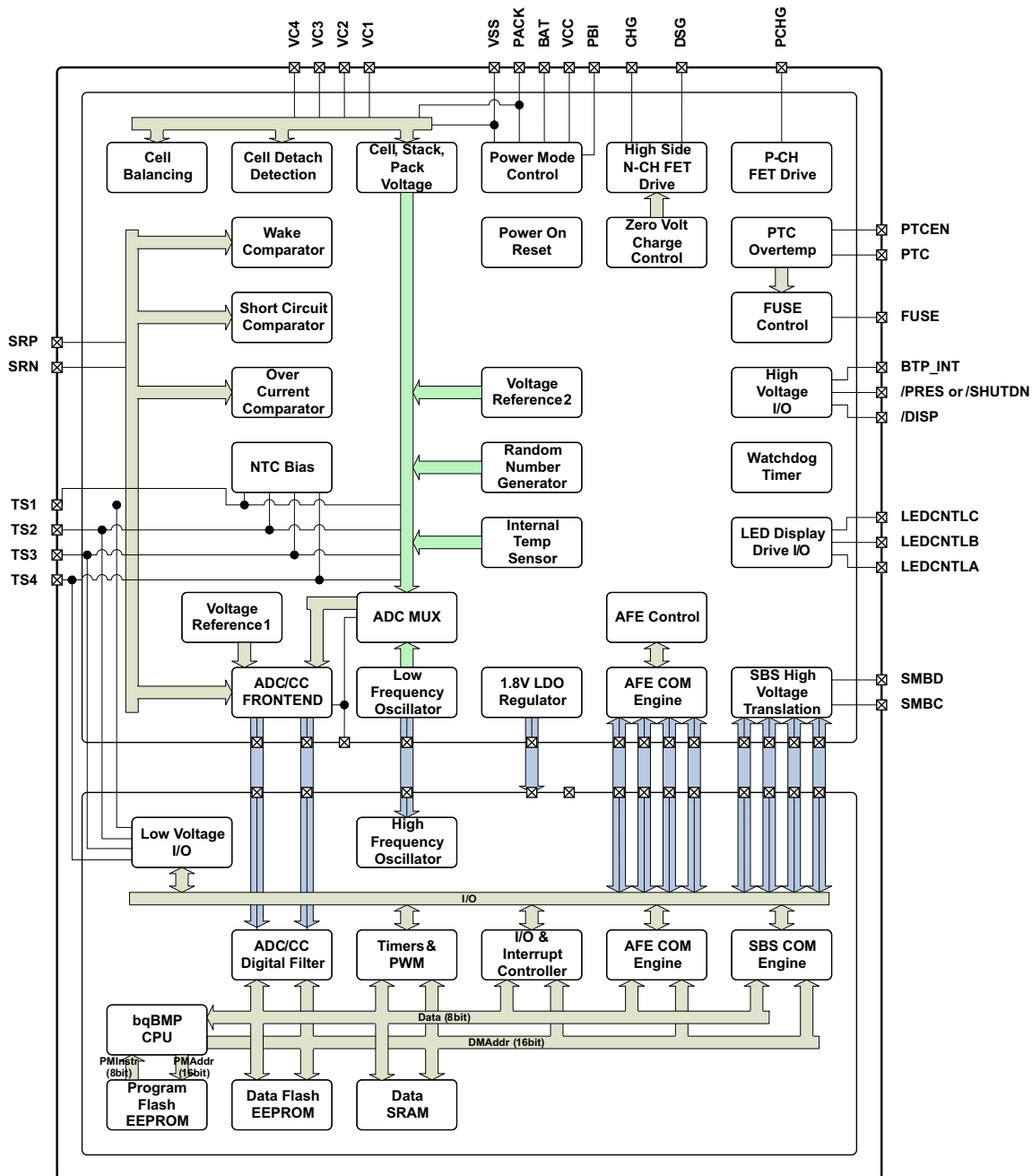

8.3 Feature Description

8.3.1 Primary (1st Level) Safety Features

The bq40z50-R1 supports a wide range of battery and system protection features that can easily be configured. See the *bq40z50-R1 Technical Reference Manual (SLUUBC1)* for detailed descriptions of each protection function.

The primary safety features include:

- Cell Overvoltage Protection
- Cell Undervoltage Protection
- Cell Undervoltage Protection Compensated
- Overcurrent in Charge Protection
- Overcurrent in Discharge Protection
- Overload in Discharge Protection
- Short Circuit in Charge Protection
- Short Circuit in Discharge Protection
- Overtemperature in Charge Protection
- Overtemperature in Discharge Protection
- Undertemperature in Charge Protection
- Undertemperature in Discharge Protection
- Overtemperature FET protection
- Precharge Timeout Protection
- Host Watchdog Timeout Protection
- Fast Charge Timeout Protection
- Overcharge Protection
- Overcharging Voltage Protection
- Overcharging Current Protection
- Over Precharge Current Protection

8.3.2 Secondary (2nd Level) Safety Features

The secondary safety features of the bq40z50-R1 can be used to indicate more serious faults via the FUSE pin. This pin can be used to blow an in-line fuse to permanently disable the battery pack from charging or discharging. See the *bq40z50-R1 Technical Reference Manual (SLUUBC1)* for detailed descriptions of each protection function.

The secondary safety features provide protection against:

- Safety Overvoltage Permanent Failure
- Safety Undervoltage Permanent Failure
- Safety Overtemperature Permanent Failure
- Safety FET Overtemperature Permanent Failure
- Qmax Imbalance Permanent Failure
- Impedance Imbalance Permanent Failure
- Capacity Degradation Permanent Failure
- Cell Balancing Permanent Failure
- Fuse Failure Permanent Failure
- PTC Permanent Failure
- Voltage Imbalance at Rest Permanent Failure
- Voltage Imbalance Active Permanent Failure
- Charge FET Permanent Failure
- Discharge FET Permanent Failure
- AFE Register Permanent Failure
- AFE Communication Permanent Failure

Feature Description (continued)

- Second Level Protector Permanent Failure
- Instruction Flash Checksum Permanent Failure
- Open Cell Connection Permanent Failure
- Data Flash Permanent Failure
- Open Thermistor Permanent Failure

8.3.3 Charge Control Features

The bq40z50-R1 charge control features include:

- Supports JEITA temperature ranges. Reports charging voltage and charging current according to the active temperature range
- Handles more complex charging profiles. Allows for splitting the standard temperature range into two sub-ranges and allows for varying the charging current according to the cell voltage
- Reports the appropriate charging current needed for constant current charging and the appropriate charging voltage needed for constant voltage charging to a smart charger using SMBus broadcasts
- Reduces the charge difference of the battery cells in fully charged state of the battery pack gradually using a voltage-based cell balancing algorithm during charging. A voltage threshold can be set up for cell balancing to be active. This prevents fully charged cells from overcharging and causing excessive degradation and also increases the usable pack energy by preventing premature charge termination.
- Supports pre-charging/zero-volt charging
- Supports charge inhibit and charge suspend if battery pack temperature is out of temperature range
- Reports charging fault and also indicates charge status via charge and discharge alarms

8.3.4 Gas Gauging

The bq40z50-R1 uses the Impedance Track algorithm to measure and calculate the available capacity in battery cells. The bq40z50-R1 accumulates a measure of charge and discharge currents and compensates the charge current measurement for the temperature and state-of-charge of the battery. The bq40z50-R1 estimates self-discharge of the battery and also adjusts the self-discharge estimation based on temperature. The device also has TURBO BOOST mode support, which enables the bq40z50-R1 to provide the necessary data for the MCU to determine what level of peak power consumption can be applied without causing a system reset or transient battery voltage level spike to trigger termination flags. See the *bq40z50-R1 Technical Reference Manual (SLUUBC1)* for further details.

8.3.5 Configuration

8.3.5.1 Oscillator Function

The bq40z50-R1 fully integrates the system oscillators and does not require any external components to support this feature.

8.3.5.2 System Present Operation

The bq40z50-R1 checks the $\overline{\text{PRES}}$ pin periodically (1 s). If $\overline{\text{PRES}}$ input is pulled to ground by the external system, the bq40z50-R1 detects this as system present.

8.3.5.3 Emergency Shutdown

For battery maintenance, the emergency shutdown feature enables a push button action connecting the SHUTDN pin to shutdown an embedded battery pack system before removing the battery. A high-to-low transition of the SHUTDN pin signals the bq40z50-R1 to turn off both CHG and DSG FETs, disconnecting the power from the system to safely remove the battery pack. The CHG and DSG FETs can be turned on again by another high-to-low transition detected by the SHUTDN pin or when a data flash configurable timeout is reached.

8.3.5.4 1-Series, 2-Series, 3-Series, or 4-Series Cell Configuration

In a 1-series cell configuration, VC4 is shorted to VC, VC2 and VC1. In a 2-series cell configuration, VC4 is shorted to VC3 and VC2. In a 3-series cell configuration, VC4 is shorted to VC3.

Feature Description (continued)

8.3.5.5 Cell Balancing

The device supports cell balancing by bypassing the current of each cell during charging or at rest. If the device's internal bypass is used, up to 10 mA can be bypassed and multiple cells can be bypassed at the same time. Higher cell balance current can be achieved by using an external cell balancing circuit. In external cell balancing mode, only one cell at a time can be balanced.

The cell balancing algorithm determines the amount of charge needed to be bypassed to balance the capacity of all cells.

8.3.6 Battery Parameter Measurements

8.3.6.1 Charge and Discharge Counting

The bq40z50-R1 uses an integrating delta-sigma analog-to-digital converter (ADC) for current measurement, and a second delta-sigma ADC for individual cell and battery voltage and temperature measurement.

The integrating delta-sigma ADC measures the charge/discharge flow of the battery by measuring the voltage drop across a small-value sense resistor between the SRP and SRN terminals. The integrating ADC measures bipolar signals from -0.1 V to 0.1 V. The bq40z50-R1 detects charge activity when $V_{SR} = V_{(SRP)} - V_{(SRN)}$ is positive, and discharge activity when $V_{SR} = V_{(SRP)} - V_{(SRN)}$ is negative. The bq40z50-R1 continuously integrates the signal over time, using an internal counter. The fundamental rate of the counter is 0.26 nVh.

8.3.7 Battery Trip Point (BTP)

Required for WIN8 OS, the battery trip point (BTP) feature indicates when the RSOC of a battery pack has depleted to a certain value set in a DF register. This feature allows a host to program two capacity-based thresholds that govern the triggering of a BTP interrupt on the BTP_INT pin and the setting or clearing of the *OperationStatus[BTP_INT]* on the basis of *RemainingCapacity()*.

An internal weak pull-up is applied when the BTP feature is active. Depending on the system design, an external pull-up may be required to put on the BTP_INT pin. See [Electrical Characteristics: PRES, BTP_INT, DISP](#) for details.

8.3.8 Lifetime Data Logging Features

The bq40z50-R1 offers lifetime data logging for several critical battery parameters. The following parameters are updated every 10 hours if a difference is detected between values in RAM and data flash:

- Maximum and Minimum Cell Voltages
- Maximum Delta Cell Voltage
- Maximum Charge Current
- Maximum Discharge Current
- Maximum Average Discharge Current
- Maximum Average Discharge Power
- Maximum and Minimum Cell Temperature
- Maximum Delta Cell Temperature
- Maximum and Minimum Internal Sensor Temperature
- Maximum FET Temperature
- Number of Safety Events Occurrences and the Last Cycle of the Occurrence
- Number of Valid Charge Termination and the Last Cycle of the Valid Charge Termination
- Number of Qmax and Ra Updates and the Last Cycle of the Qmax and Ra Updates
- Number of Shutdown Events
- Cell Balancing Time for Each Cell
(This data is updated every 2 hours if a difference is detected.)
- Total FW Runtime and Time Spent in Each Temperature Range
(This data is updated every 2 hours if a difference is detected.)

Feature Description (continued)

8.3.9 Authentication

The bq40z50-R1 supports authentication by the host using SHA-1.

8.3.10 LED Display

The bq40z50-R1 can drive a 3-, 4-, or 5- segment LED display for remaining capacity indication and/or a permanent fail (PF) error code indication.

8.3.11 Voltage

The bq40z50-R1 updates the individual series cell voltages at 0.25-second intervals. The internal ADC of the bq40z50-R1 measures the voltage, and scales and calibrates it appropriately. This data is also used to calculate the impedance of the cell for the Impedance Track gas gauging.

8.3.12 Current

The bq40z50-R1 uses the SRP and SRN inputs to measure and calculate the battery charge and discharge current using a 1-m Ω to 3-m Ω typ. sense resistor.

8.3.13 Temperature

The bq40z50-R1 has an internal temperature sensor and inputs for four external temperature sensors. All five temperature sensor options can be individually enabled and configured for cell or FET temperature usage. Two configurable thermistor models are provided to allow the monitoring of cell temperature in addition to FET temperature, which use a different thermistor profile.

8.3.14 Communications

The bq40z50-R1 uses SMBus v1.1 with MASTER mode and packet error checking (PEC) options per the SBS specification.

8.3.14.1 SMBus On and Off State

The bq40z50-R1 detects an SMBus off state when SMBC and SMBD are low for two or more seconds. Clearing this state requires that either SMBC or SMBD transition high. The communication bus will resume activity within 1 ms.

8.3.14.2 SBS Commands

See the *bq40z50-R1 Technical Reference Manual* ([SLUUBC1](#)) for further details.

8.4 Device Functional Modes

The bq40z50-R1 supports three power modes to reduce power consumption:

- In NORMAL mode, the bq40z50-R1 performs measurements, calculations, protection decisions, and data updates in 250-ms intervals. Between these intervals, the bq40z50-R1 is in a reduced power stage.
- In SLEEP mode, the bq40z50-R1 performs measurements, calculations, protection decisions, and data updates in adjustable time intervals. Between these intervals, the bq40z50-R1 is in a reduced power stage. The bq40z50-R1 has a wake function that enables exit from SLEEP mode when current flow or failure is detected.
- In SHUTDOWN mode, the bq40z50-R1 is completely disabled.

9 Applications and Implementation

NOTE

Information in the following applications sections is not part of the TI component specification, and TI does not warrant its accuracy or completeness. TI's customers are responsible for determining suitability of components for their purposes. Customers should validate and test their design implementation to confirm system functionality.

9.1 Application Information

The bq40z50-R1 is a gas gauge with primary protection support, and that can be used with a 1-series to 4-series Li-Ion/Li Polymer battery pack. To implement and design a comprehensive set of parameters for a specific battery pack, users need the Battery Management Studio (bqSTUDIO) graphical user-interface tool installed on a PC during development. The firmware installed on the bqSTUDIO tool has default values for this product, which are summarized in the *bq40z50-R1 Technical Reference Manual* ([SLUUBC1](#)). Using the bqSTUDIO tool, these default values can be changed to cater to specific application requirements during development once the system parameters, such as fault trigger thresholds for protection, enable/disable of certain features for operation, configuration of cells, chemistry that best matches the cell used, and more are known. This data is referred to as the "golden image."

9.2 Typical Applications

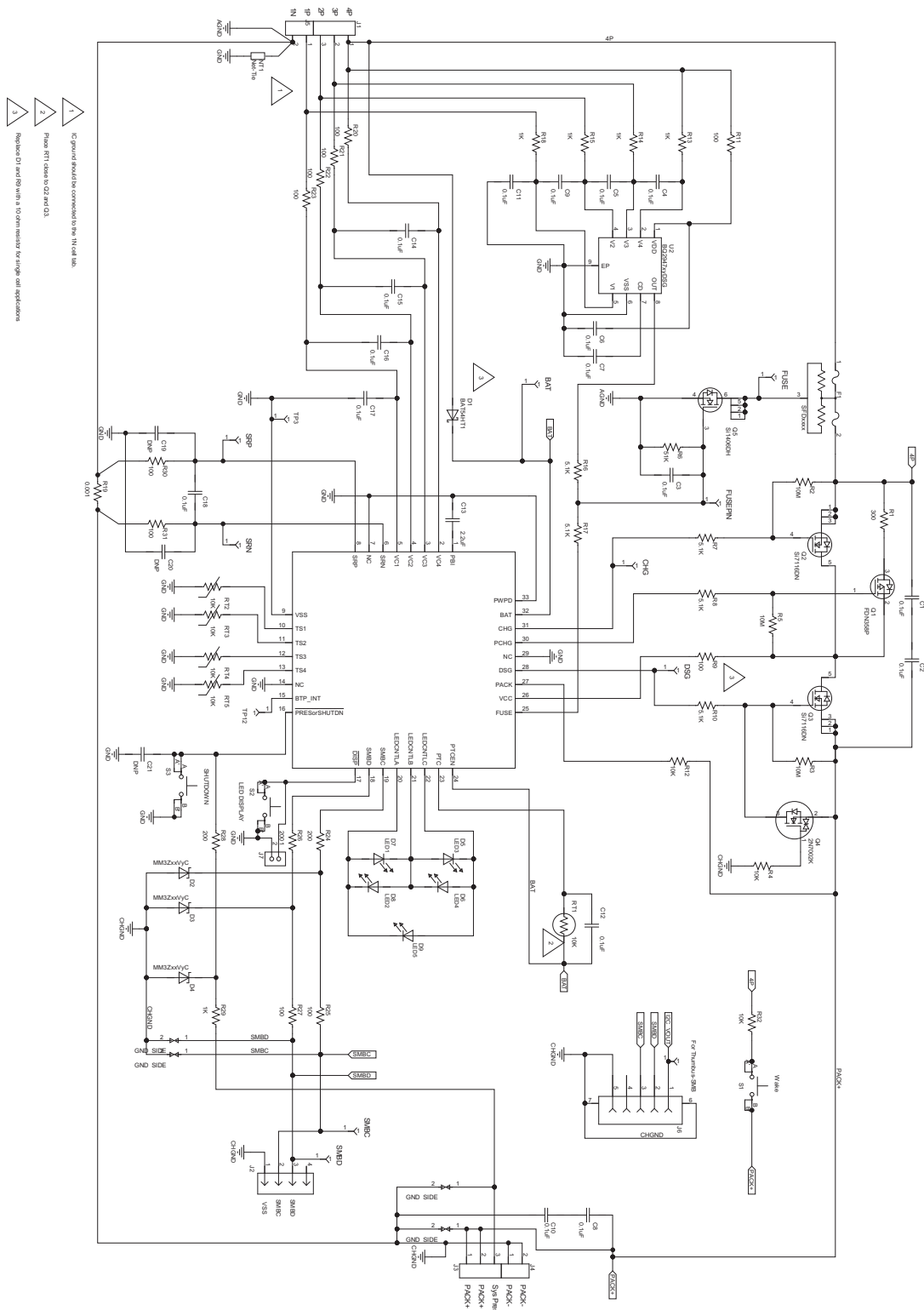

Figure 21. Application Schematic

Typical Applications (continued)

9.2.1 Design Requirements

Table 1 shows the default settings for the main parameters. Use the bqSTUDIO tool to update the settings to meet the specific application or battery pack configuration requirements.

The device should be calibrated before any gauging test. Follow the bqSTUDIO **Calibration** page to calibrate the device, and use the bqSTUDIO **Chemistry** page to update the match chemistry profile to the device.

Table 1. Design Parameters

DESIGN PARAMETER	EXAMPLE
Cell Configuration	3s1p (3-series with 1 Parallel) ⁽¹⁾
Design Capacity	4400 mAh
Device Chemistry	1210 (LiCoO ₂ /graphitized carbon)
Cell Overvoltage at Standard Temperature	4300 mV
Cell Undervoltage	2500 mV
Shutdown Voltage	2300 mV
Overcurrent in CHARGE Mode	6000 mA
Overcurrent in DISCHARGE Mode	–6000 mA
Short Circuit in CHARGE Mode	0.1 V/R _{sense} across SRP, SRN
Short Circuit in DISCHARGE Mode	0.1 V/R _{sense} across SRP, SRN
Safety Overvoltage	4500 mV
Cell Balancing	Disabled
Internal and External Temperature Sensor	External Temperature Sensor is used.
Undertemperature Charging	0°C
Undertemperature Discharging	0°C
BROADCAST Mode	Disabled
Battery Trip Point (BTP) with active high interrupt	Disabled

(1) When using the device the first time, if the a 1-s or 2-s battery pack is used, then a charger or power supply should be connected to the PACK+ terminal to prevent device shutdown. Then update the cell configuration (see the *bq40z50-R1 Technical Reference Manual [SLUUBC1]* for details) before removing the charger connection.

9.2.2 Detailed Design Procedure

9.2.2.1 High-Current Path

The high-current path begins at the PACK+ terminal of the battery pack. As charge current travels through the pack, it finds its way through protection FETs, a chemical fuse, the lithium-ion cells and cell connections, and the sense resistor, and then returns to the PACK– terminal (see [Figure 22](#)). In addition, some components are placed across the PACK+ and PACK– terminals to reduce effects from electrostatic discharge.

9.2.2.1.1 Protection FETs

Select the N-channel charge and discharge FETs for a given application. Most portable battery applications are a good match for the CSD17308Q3. The TI CSD17308Q3 is a 47A, 30-V device with R_{ds(on)} of 8.2 mΩ when the gate drive voltage is 8 V.

If a precharge FET is used, R₁ is calculated to limit the precharge current to the desired rate. Be sure to account for the power dissipation of the series resistor. The precharge current is limited to $(V_{\text{CHARGER}} - V_{\text{BAT}})/R_1$ and maximum power dissipation is $(V_{\text{charger}} - V_{\text{bat}})^2/R_1$.

The gates of all protection FETs are pulled to the source with a high-value resistor between the gate and source to ensure they are turned off if the gate drive is open.

Capacitors C1 and C2 help protect the FETs during an ESD event. Using two devices ensures normal operation if one becomes shorted. To have good ESD protection, the copper trace inductance of the capacitor leads must be designed to be as short and wide as possible. Ensure that the voltage rating of both C1 and C2 are adequate to hold off the applied voltage if one of the capacitors becomes shorted.

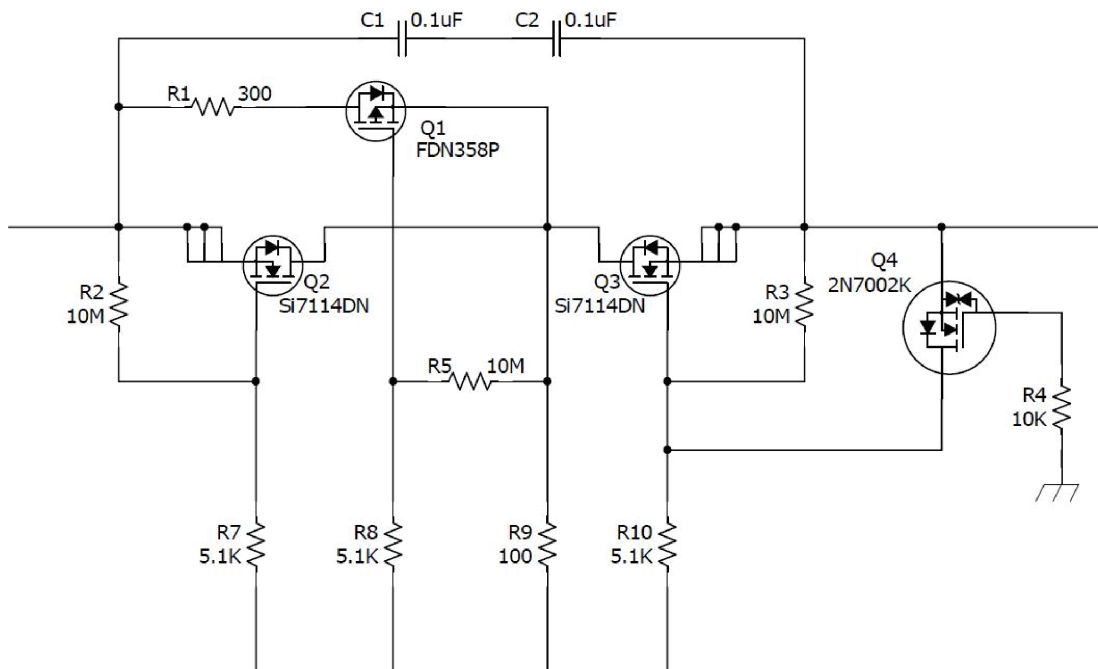

Figure 22. bq40z50-R1 Protection FETs

9.2.2.1.2 Chemical Fuse

The chemical fuse (Dexerials, Uchihashi, and so forth) is ignited under command from either the bq294700 secondary voltage protection IC or from the FUSE pin of the gas gauge. Either of these events applies a positive voltage to the gate of Q5, shown in [Figure 23](#), which then sinks current from the third terminal of the fuse, causing it to ignite and open permanently.

It is important to carefully review the fuse specifications and match the required ignition current to that available from the N-channel FET. Ensure that the proper voltage, current, and $R_{ds(on)}$ ratings are used for this device. The fuse control circuit is discussed in detail in [FUSE Circuitry](#).

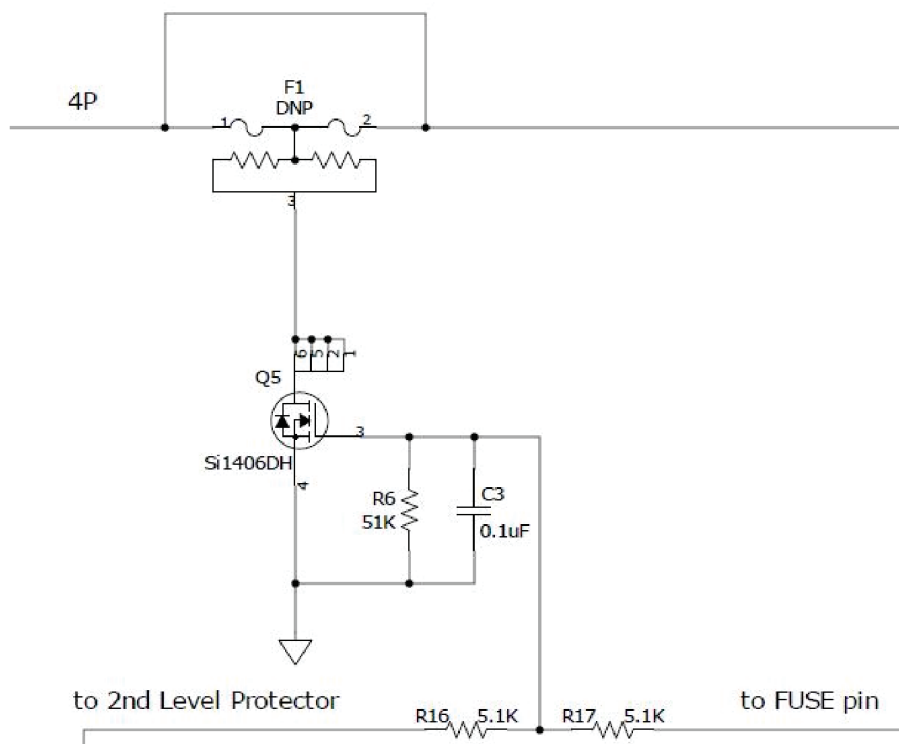

Figure 23. FUSE Circuit

9.2.2.1.3 Lithium-Ion Cell Connections

The important part to remember about the cell connections is that high current flows through the top and bottom connections; therefore, the voltage sense leads at these points must be made with a Kelvin connection to avoid any errors due to a drop in the high-current copper trace. The location marked 4P in Figure 24 indicates the Kelvin connection of the most positive battery node. The connection marked 1N is equally important. The VC5 pin (a ground reference for cell voltage measurement), which is in the older generation devices, is not in the bq40z50-R1 device. Therefore, the single-point connection at 1N to the low-current ground is needed to avoid an undesired voltage drop through long traces while the gas gauge is measuring the bottom cell voltage.

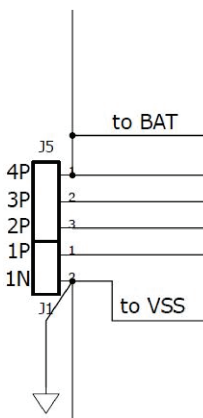

Figure 24. Lithium-Ion Cell Connections

9.2.2.1.4 Sense Resistor

As with the cell connections, the quality of the Kelvin connections at the sense resistor is critical. The sense resistor must have a temperature coefficient no greater than 50 ppm in order to minimize current measurement drift with temperature. Choose the value of the sense resistor to correspond to the available overcurrent and short-circuit ranges of the bq40z50-R1. Select the smallest value possible to minimize the negative voltage generated on the bq40z50-R1 V_{SS} node(s) during a short circuit. This pin has an absolute minimum of -0.3 V. Parallel resistors can be used as long as good Kelvin sensing is ensured. The device is designed to support a 1-m Ω to 3-m Ω sense resistor.

The ground scheme of bq40z50-R1 is different from the older generation devices. In previous devices, the device ground (or low current ground) is connected to the SRN side of the Rsense resistor pad. The bq40z50-R1, however, connects the low-current ground on the SRP side of the Rsense resistor pad, close to the battery 1N terminal (see [Lithium-Ion Cell Connections](#)). This is because the bq40z50-R1 has one less VC pin (a ground reference pin VC5) compared to the previous devices. The pin was removed and was internally combined to SRP.

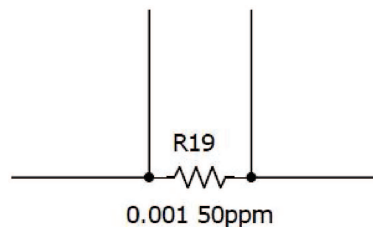

Figure 25. Sense Resistor

9.2.2.1.5 ESD Mitigation

A pair of series 0.1- μ F ceramic capacitors is placed across the PACK+ and PACK– terminals to help in the mitigation of external electrostatic discharges. The two devices in series ensure continued operation of the pack if one of the capacitors becomes shorted.

Optionally, a tranzorb such as the SMBJ2A can be placed across the terminals to further improve ESD immunity.

9.2.2.2 Gas Gauge Circuit

The Gas Gauge Circuit includes the bq40z50-R1 and its peripheral components. These components are divided into the following groups: Differential Low-Pass Filter, PBI, System Present, SMBus Communication, FUSE circuit, and LED.

9.2.2.2.1 Coulomb-Counting Interface

The bq40z50-R1 uses an integrating delta-sigma ADC for current measurements. Add a 100- Ω resistor from the sense resistor to the SRP and SRN inputs of the device. Place a 0.1- μ F (C18) filter capacitor across the SRP and SRN inputs. Optional 0.1- μ F filter capacitors (C19 and C20) can be added for additional noise filtering, if required for your circuit.

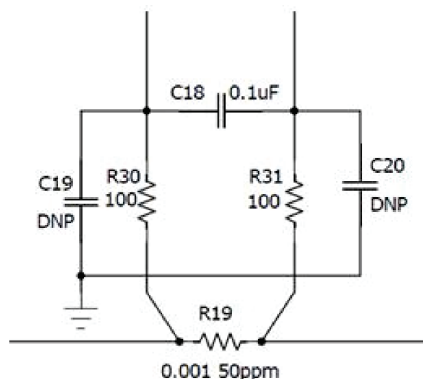

Figure 26. Differential Filter

9.2.2.2.2 Power Supply Decoupling and PBI

The bq40z50-R1 has an internal LDO that is internally compensated and does not require an external decoupling capacitor.

The PBI pin is used as a power supply backup input pin providing power during brief transient power outages. A standard 2.2- μ F ceramic capacitor is connected from the PBI pin to ground as shown in Figure 27.

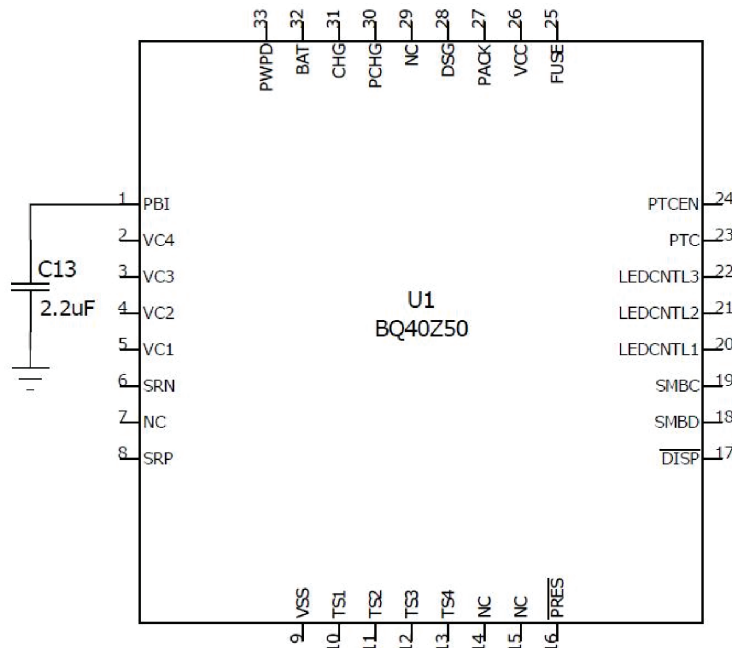

Figure 27. Power Supply Decoupling

9.2.2.2.3 System Present

The System Present signal is used to inform the gas gauge whether the pack is installed into or removed from the system. In the host system, this pin is grounded. The PRES pin of the bq40z50-R1 is occasionally sampled to test for system present. To save power, an internal pullup is provided by the gas gauge during a brief 4- μ s sampling pulse once per second. A resistor can be used to pull the signal low and the resistance must be 20 k Ω or lower to insure that the test pulse is lower than the VIL limit. The pull-up current source is typically 10 μ A to 20 μ A.

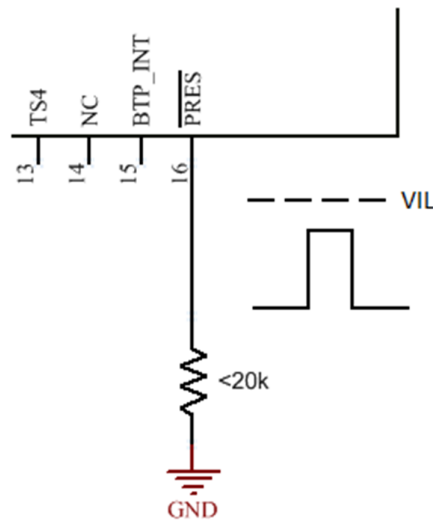

Figure 28. System Present Pull-Down Resistor

Because the System Present signal is part of the pack connector interface to the outside world, it must be protected from external electrostatic discharge events. An integrated ESD protection on the PRES device pin reduces the external protection requirement to just R29 for an 8-kV ESD contact rating. However, if it is possible that the System Present signal may short to PACK+, then R28 and D4 must be included for high-voltage protection.

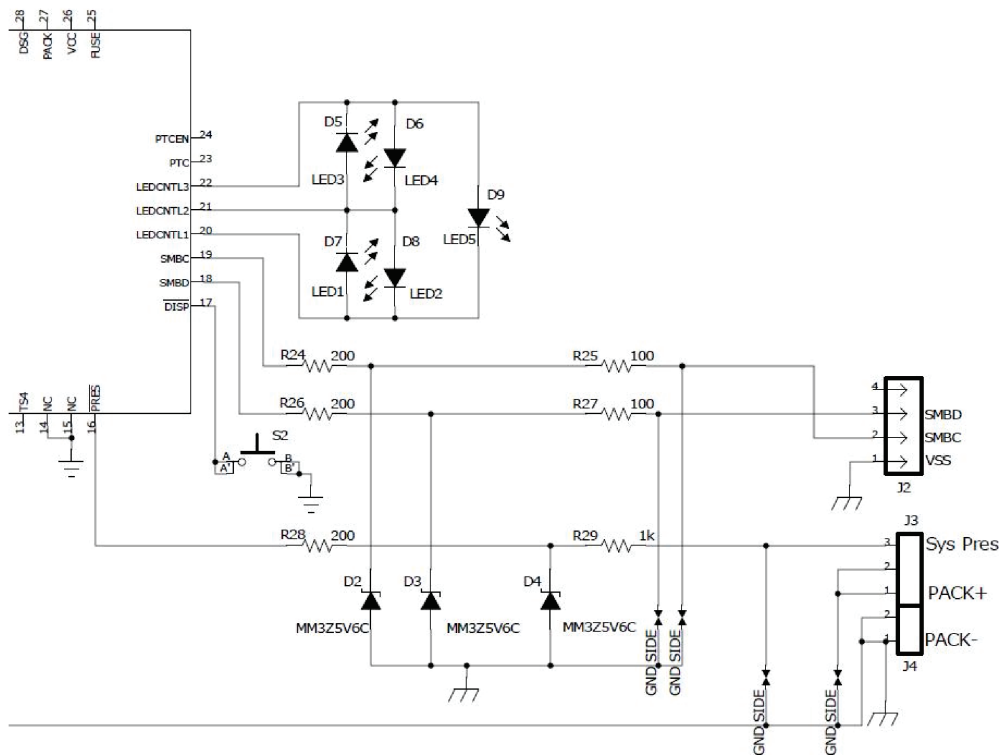

Figure 29. System Present ESD and Short Protection

9.2.2.2.4 SMBus Communication

The SMBus clock and data pins have integrated high-voltage ESD protection circuits, however, adding a Zener diode (D2 and D3) and series resistor (R24 and R26) provides more robust ESD performance.

The SMBus clock and data lines have internal pulldown. When the gas gauge senses that both lines are low (such as during removal of the pack), the device performs auto-offset calibration and then goes into SLEEP mode to conserve power.

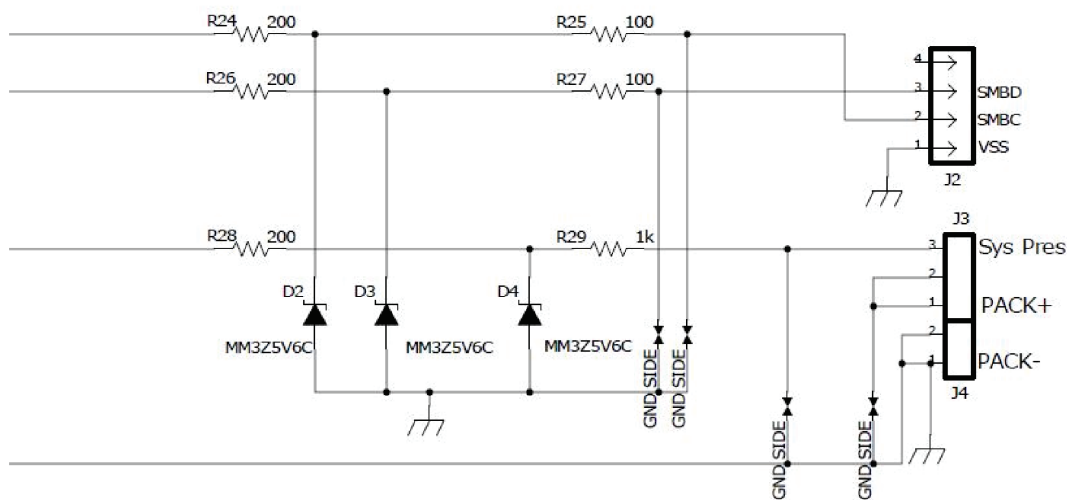

Figure 30. ESD Protection for SMB Communication

9.2.2.2.5 FUSE Circuitry

The FUSE pin of the bq40z50-R1 is designed to ignite the chemical fuse if one of the various safety criteria is violated. The FUSE pin also monitors the state of the secondary-voltage protection IC. Q5 ignites the chemical fuse when its gate is high. The 7-V output of the bq294700 is divided by R16 and R6, which provides adequate gate drive for Q5 while guarding against excessive back current into the bq294700 if the FUSE signal is high.

Using C3 is generally a good practice, especially for RFI immunity. C3 may be removed, if desired, because the chemical fuse is a comparatively slow device and is not affected by any sub-microsecond glitches that come from the FUSE output during the cell connection process.

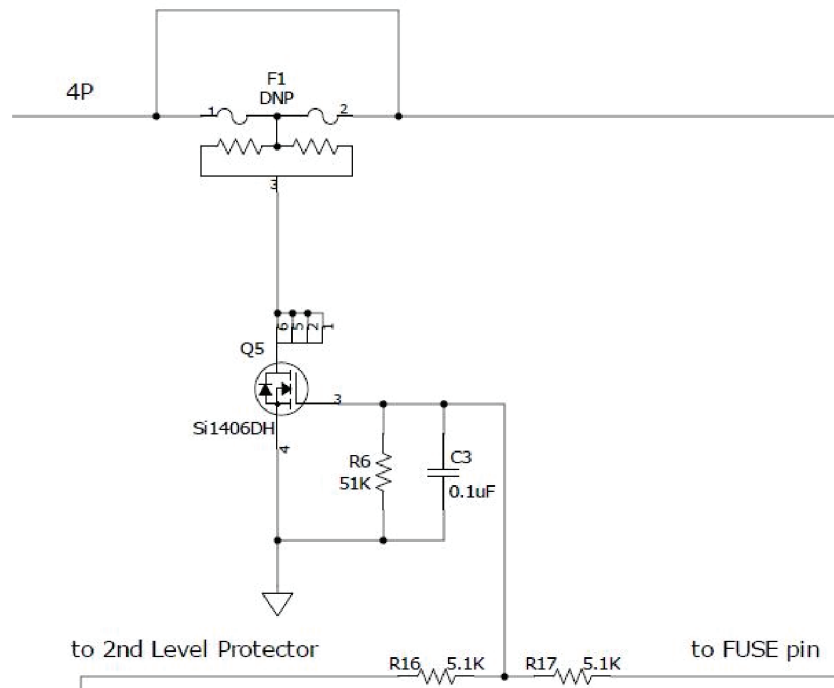

Figure 31. FUSE Circuit

When the bq40z50-R1 is commanded to ignite the chemical fuse, the FUSE pin activates to give a typical 8-V output. The new design makes it possible to use a higher V_{gs} FET for Q5. This improves the robustness of the system, as well as widens the choices for Q5.

9.2.2.3 Secondary-Current Protection

The bq40z50-R1 provides secondary overcurrent and short-circuit protection, cell balancing, cell voltage multiplexing, and voltage translation. The following discussion examines Cell and Battery Inputs, Pack and FET Control, Temperature Output, and Cell Balancing.

9.2.2.3.1 Cell and Battery Inputs

Each cell input is conditioned with a simple RC filter, which provides ESD protection during cell connect and acts to filter unwanted voltage transients. The resistor value allows some trade-off for cell balancing versus safety protection.

The integrated cell balancing FETs allow the AFE to bypass cell current around a given cell or numerous cells, effectively balancing the entire battery stack. External series resistors placed between the cell connections and the VCx I/O pins set the balancing current magnitude. The internal FETs provide a 200- Ω resistance ($2\text{ V} < V_{DS} < 4\text{ V}$). Series input resistors between 100 Ω and 1 k Ω are recommended for effective cell balancing.

The BAT input uses a diode (D1) to isolate and decouple it from the cells in the event of a transient dip in voltage caused by a short-circuit event.

Also, as described in [High-Current Path](#), the top and bottom nodes of the cells must be sensed at the battery connections with a Kelvin connection to prevent voltage sensing errors caused by a drop in the high-current PCB copper.

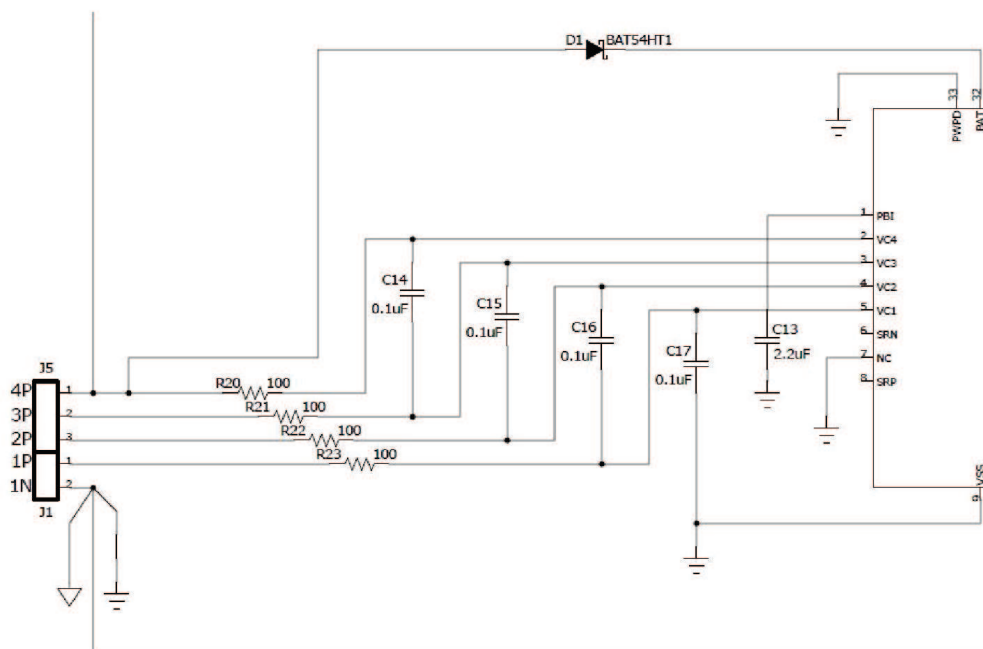

Figure 32. Cell and BAT Inputs

9.2.2.3.2 External Cell Balancing

Internal cell balancing can only support up to 10 mA. External cell balancing provide as another option for faster cell balancing. For details, refer to the application note, *Fast Cell Balancing Using External MOSFET (SLUA420)*.

9.2.2.3.3 PACK and V_{CC} Control

The PACK and V_{CC} inputs provide power to the bq40z50-R1 from the charger. The PACK input also provides a method to measure and detect the presence of a charger. The PACK input uses a 100-Ω resistor; whereas, the V_{CC} input uses a diode to guard against input transients and prevents mis-operation of the data driver during short-circuit events.

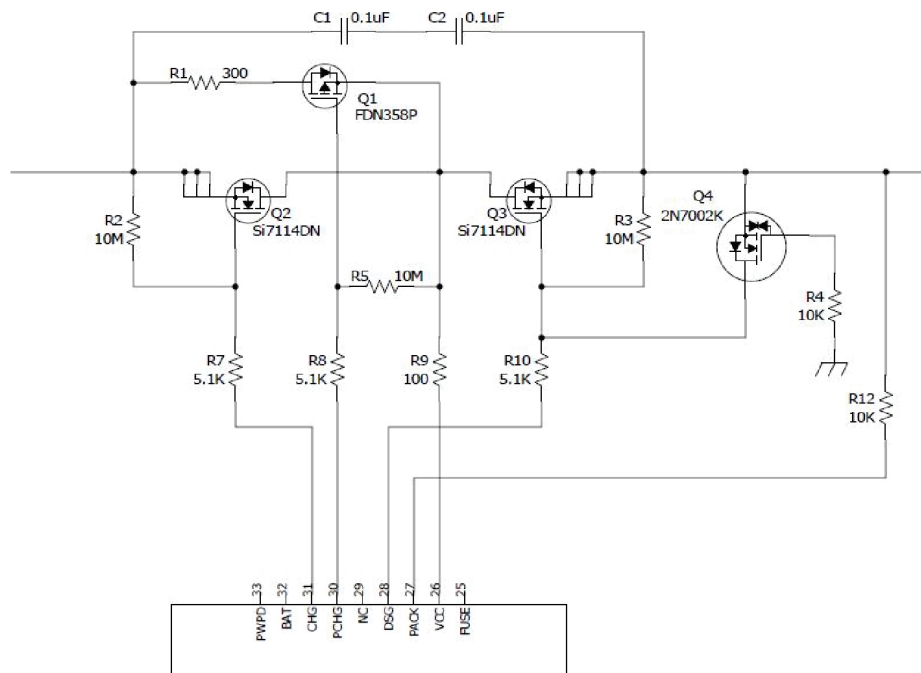

Figure 33. bq40z50-R1 PACK and FET Control

The N-channel charge and discharge FETs are controlled with 5.1-k Ω series gate resistors, which provide a switching time constant of a few microseconds. The 10-M Ω resistors ensure that the FETs are off in the event of an open connection to the FET drivers. Q4 is provided to protect the discharge FET (Q3) in the event of a reverse-connected charger. Without Q4, Q3 can be driven into its linear region and suffer severe damage if the PACK+ input becomes slightly negative.

Q4 turns on in that case to protect Q3 by shorting its gate to source. To use the simple ground gate circuit, the FET must have a low gate turn-on threshold. If it is desired to use a more standard device, such as the 2N7002 as the reference schematic, the gate should be biased up to 3.3 V with a high-value resistor. The bq40z50-R1 device has the capability to provide a current-limited charging path typically used for low battery voltage or low temperature charging. The bq40z50-R1 device uses an external P-channel, pre-charge FET controlled by PCHG.

9.2.2.3.4 Temperature Output

For the bq40z50-R1 device, TS1, TS2, TS3, and TS4 provide thermistor drive-under program control. Each pin can be enabled with an integrated 18-k Ω (typical) linearization pullup resistor to support the use of a 10-k Ω at 25 $^{\circ}$ C (103) NTC external thermistor such as a Mitsubishi BN35-3H103. The reference design includes four 10-k Ω thermistors: RT1, RT2, RT3, and RT4. The bq40z50-R1 device supports up to four external thermistors. Connect unused thermistor pins to V_{SS} .

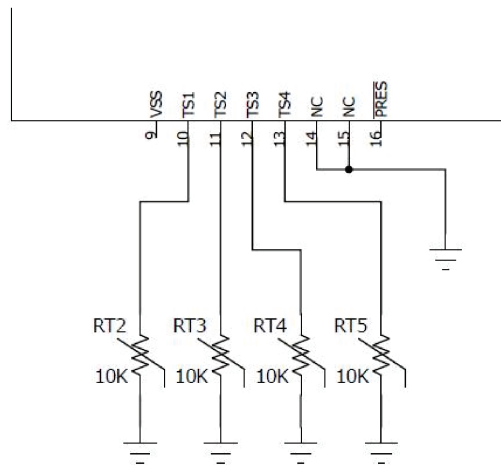

Figure 34. Thermistor Drive

9.2.2.3.5 LEDs

Three LED control outputs provide constant current sinks for the driving external LEDs. These outputs are configured to provide voltage and control for up to 5 LEDs. No external bias voltage is required. Unused LEDCNTL pins can remain open or they can be connected to V_{SS}. The DISP pin should be connected to V_{SS}, if the LED feature is not used.

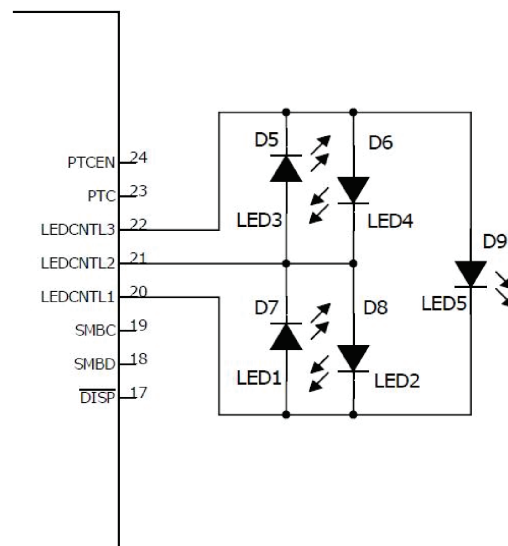

Figure 35. LEDs

9.2.2.3.6 Safety PTC Thermistor

The bq40z50-R1 device provides support for a safety PTC thermistor. The PTC thermistor is connected between the PTC pin and V_{SS}. It can be placed close to the CHG/DSG FETs to monitor the temperature. The PTC pin outputs a very small current, typical ~370 nA, and the PTC fault will be triggered at ~0.7 V typical. A PTC fault is one of the permanent failure modes. It can only be cleared by a POR.

To disable this feature, connect a 10-kΩ resistor between PTC and V_{SS}.

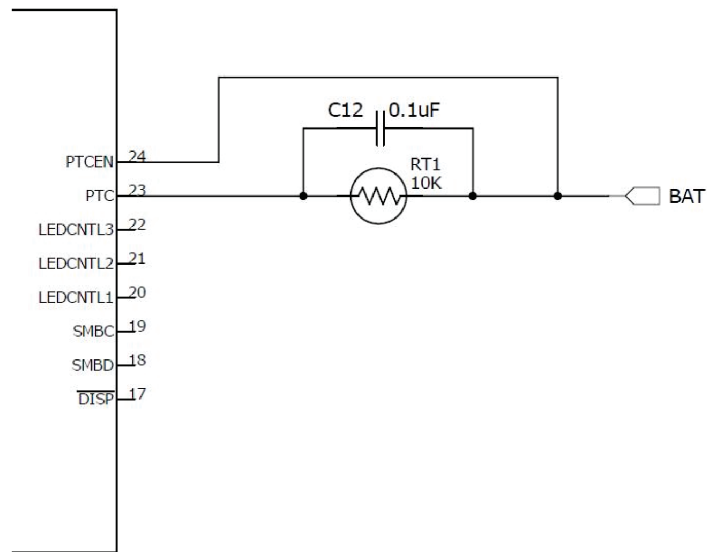
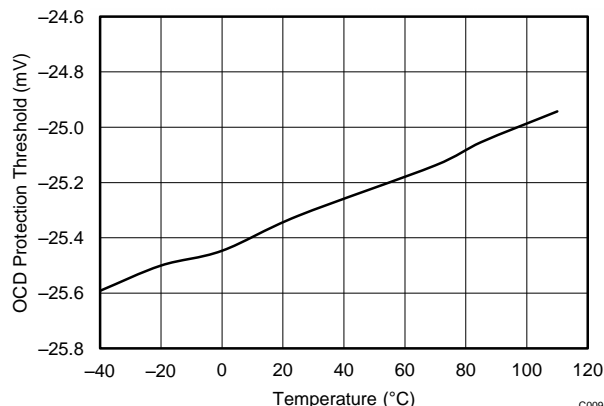

Figure 36. PTC Thermistor

9.2.3 Application Curves



Threshold setting is 25 mV.

Figure 37. Overcurrent Discharge Protection Threshold Vs. Temperature

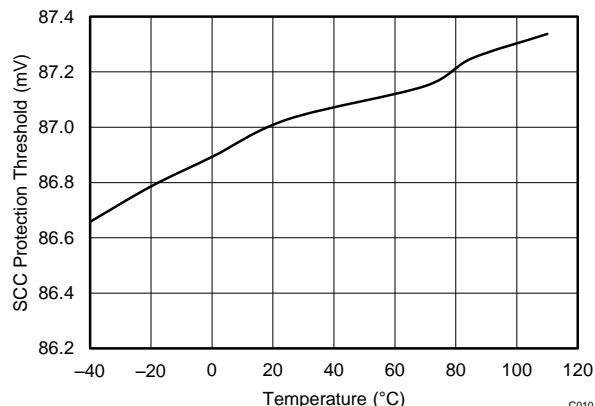

Threshold setting is 25 mV.

Figure 38. Short Circuit Charge Protection Threshold Vs. Temperature

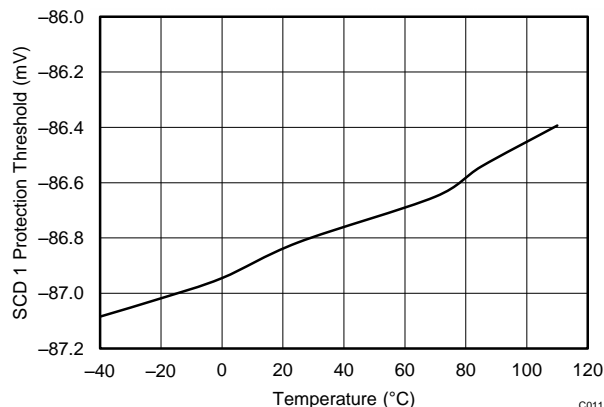

Threshold setting is -88.85 mV.

Figure 39. Short Circuit Discharge 1 Protection Threshold Vs. Temperature

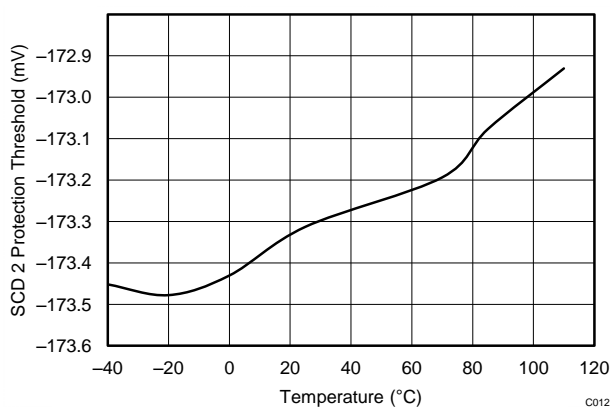

Threshold setting is -177.7 mV.

Figure 40. Short Circuit Discharge 2 Protection Threshold Vs. Temperature

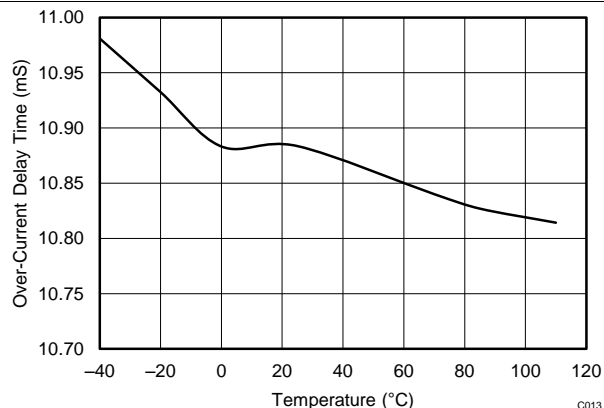

Threshold setting is 11 ms.

Figure 41. Overcurrent Delay Time Vs. Temperature

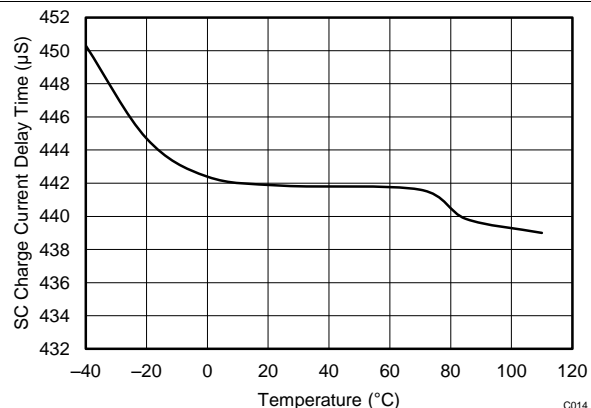

Threshold setting is 465 μs.

Figure 42. Short Circuit Charge Current Delay Time Vs. Temperature

10 Power Supply Recommendations

The device manages its supply voltage dynamically according to the operation conditions. Normally, the BAT input is the primary power source to the device. The BAT pin should be connected to the positive termination of the battery stack. The input voltage for the BAT pin ranges from 2.2 V to 26 V.

The VCC pin is the secondary power input, which activates when the BAT voltage falls below minimum Vcc. This allows the device to source power from a charger (if present) connected to the PACK pin. The VCC pin should be connected to the common drain of the CHG and DSG FETs. The charger input should be connected to the PACK pin.

11 Layout

11.1 Layout Guidelines

A battery fuel gauge circuit board is a challenging environment due to the fundamental incompatibility of high-current traces and ultra-low current semiconductor devices. The best way to protect against unwanted trace-to-trace coupling is with a component placement, such as that shown in Figure 43, where the high-current section is on the opposite side of the board from the electronic devices. Clearly this is not possible in many situations due to mechanical constraints. Still, every attempt should be made to route high-current traces away from signal traces, which enter the bq40z50-R1 directly. IC references and registers can be disturbed and in rare cases damaged due to magnetic and capacitive coupling from the high-current path. Note that during surge current and ESD events, the high-current traces appear inductive and can couple unwanted noise into sensitive nodes of the gas gauge electronics, as illustrated in Figure 44.

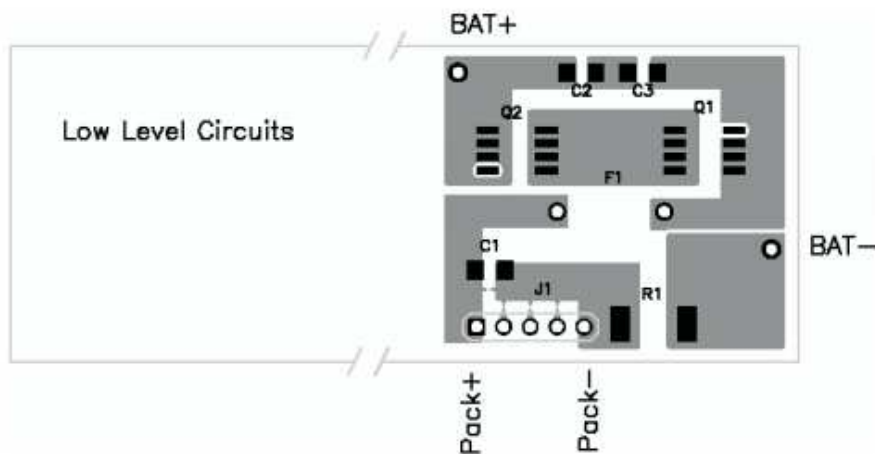

Figure 43. Separating High- and Low-Current Sections Provides an Advantage in Noise Immunity

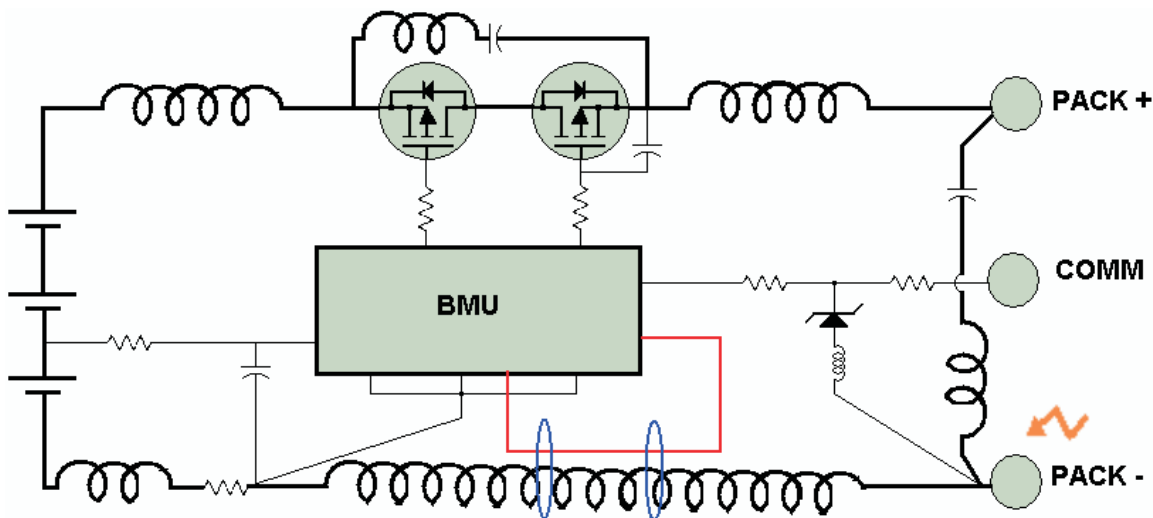

Figure 44. Avoid Close Spacing Between High-Current and Low-Level Signal Lines

Kelvin voltage sensing is extremely important in order to accurately measure current and top and bottom cell voltages. Place all filter components as close as possible to the device. Route the traces from the sense resistor in parallel to the filter circuit. Adding a ground plane around the filter network can add additional noise immunity. Figure 45 and Figure 46 demonstrates correct kelvin current sensing.

Layout Guidelines (continued)

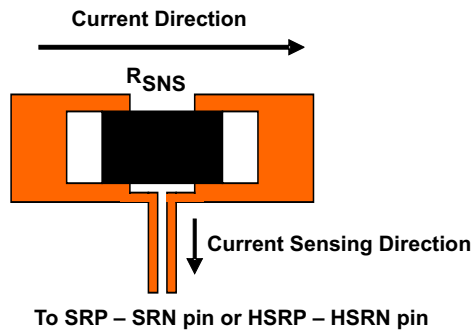

Figure 45. Sensing Resistor PCB Layout

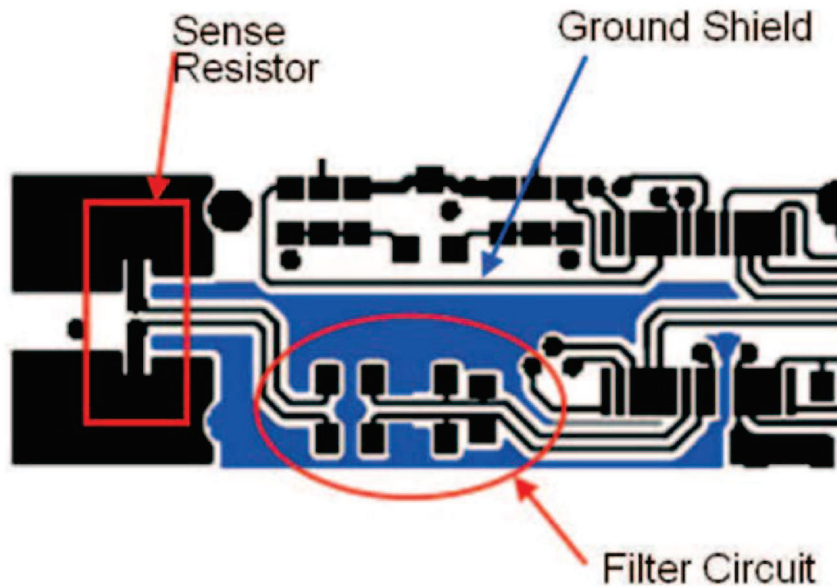

Figure 46. Sense Resistor, Ground Shield, and Filter Circuit Layout

11.1.1 Protector FET Bypass and Pack Terminal Bypass Capacitors

The general principle is to use wide copper traces to lower the inductance of the bypass capacitor circuit. In Figure 47, an example layout demonstrates this technique.

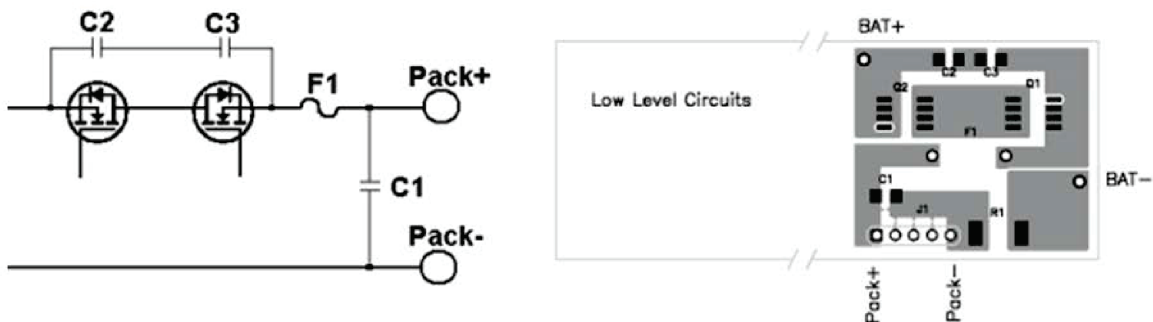

Figure 47. Use Wide Copper Traces to Lower the Inductance of Bypass Capacitors C1, C2, and C3

Layout Guidelines (continued)

11.1.2 ESD Spark Gap

Protect SMBus Clock, Data, and other communication lines from ESD with a spark gap at the connector. The pattern in Figure 48 recommended, with 0.2-mm spacing between the points.

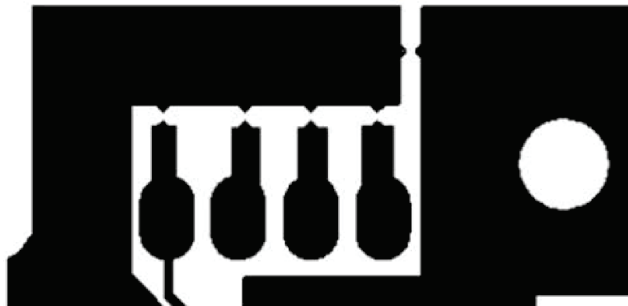

Figure 48. Recommended Spark-Gap Pattern Helps Protect Communication Lines from ESD

11.2 Layout Example

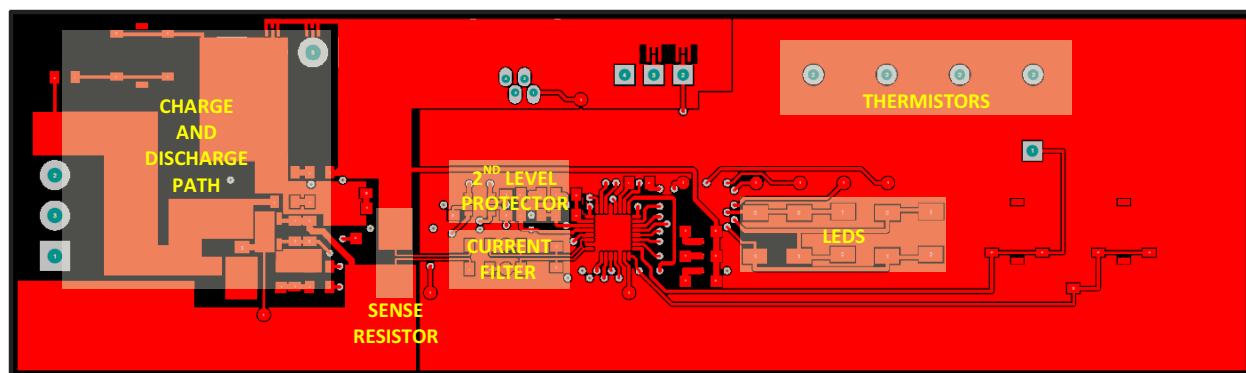

Figure 49. Top Layer

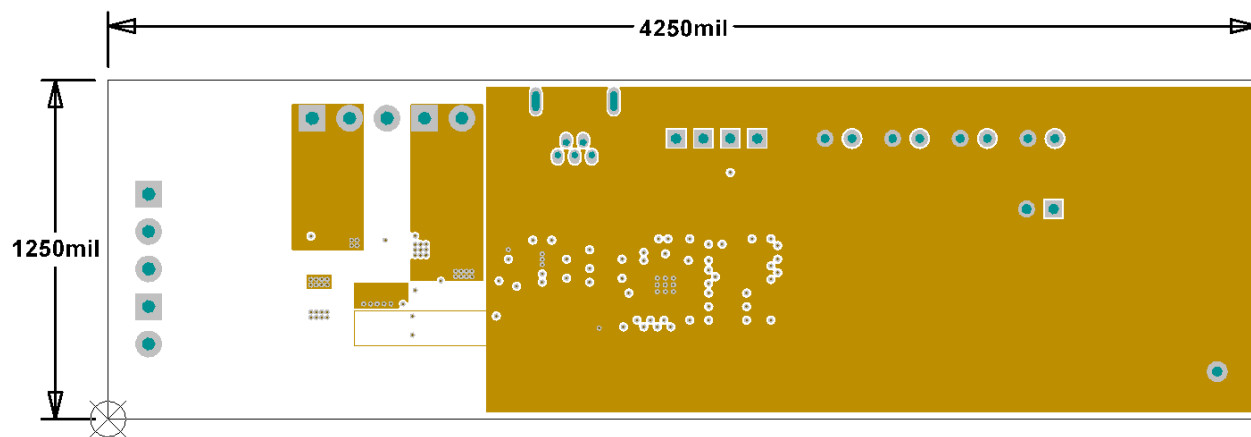

Figure 50. Internal Layer 1

Layout Example (continued)

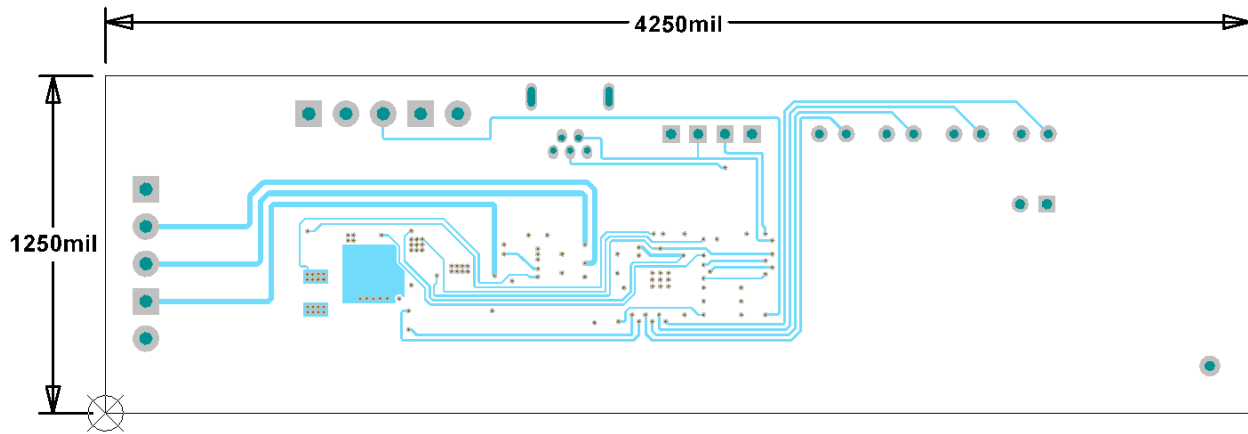

Figure 51. Internal Layer 2

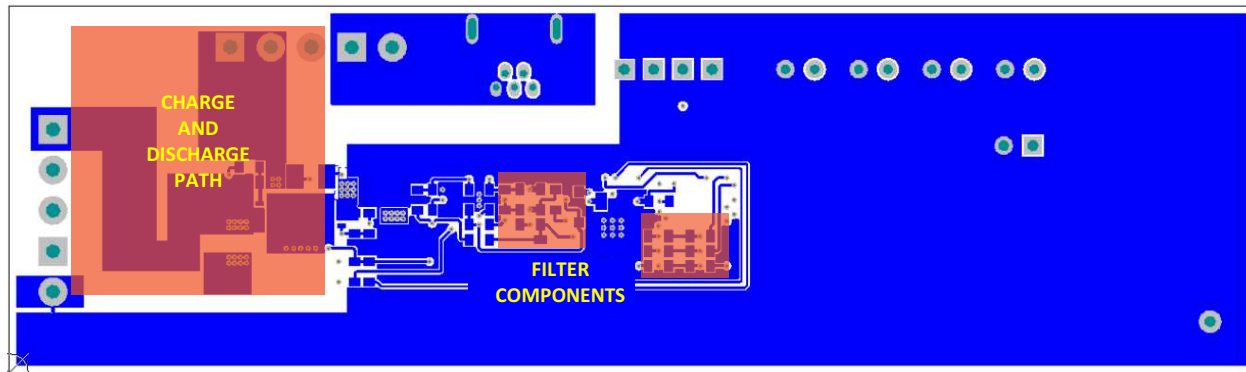

Figure 52. Bottom Layer

12 器件和文档支持

12.1 文档支持

12.1.1 相关文档

如需相关文档，请参见《*bq40z50-R1 技术参考手册*》（文献编号：[SLUUBC1](#)）。

12.2 社区资源

The following links connect to TI community resources. Linked contents are provided "AS IS" by the respective contributors. They do not constitute TI specifications and do not necessarily reflect TI's views; see TI's [Terms of Use](#).

TI E2E™ Online Community *TI's Engineer-to-Engineer (E2E) Community*. Created to foster collaboration among engineers. At [e2e.ti.com](#), you can ask questions, share knowledge, explore ideas and help solve problems with fellow engineers.

Design Support *TI's Design Support* Quickly find helpful E2E forums along with design support tools and contact information for technical support.

12.3 商标

Impedance Track, E2E are trademarks of Texas Instruments.
All other trademarks are the property of their respective owners.

12.4 静电放电警告



ESD 可能会损坏该集成电路。德州仪器 (TI) 建议通过适当的预防措施处理所有集成电路。如果不遵守正确的处理措施和安装程序，可能会损坏集成电路。

ESD 的损坏小至导致微小的性能降级，大至整个器件故障。精密的集成电路可能更容易受到损坏，这是因为非常细微的参数更改都可能会导致器件与其发布的规格不相符。

12.5 Glossary

[SLYZ022](#) — *TI Glossary*.

This glossary lists and explains terms, acronyms, and definitions.

13 机械、封装和可订购信息

以下页中包括机械、封装和可订购信息。 这些信息是针对指定器件可提供的最新数据。 这些数据会在无通知且不
对本文档进行修订的情况下发生改变。 欲获得该数据表的浏览器版本，请查阅左侧的导航栏。

重要声明

德州仪器(TI)及其下属子公司有权根据 JESD46 最新标准,对所提供的产品和服务进行更正、修改、增强、改进或其它更改,并有权根据 JESD48 最新标准中止提供任何产品和服务。客户在下订单前应获取最新的相关信息,并验证这些信息是否完整且是最新的。所有产品的销售都遵循在订单确认时所提供的TI 销售条款与条件。

TI 保证其所销售的组件的性能符合产品销售时 TI 半导体产品销售条件与条款的适用规范。仅在 TI 保证的范围内,且 TI 认为有必要时才会使用测试或其它质量控制技术。除非适用法律做出了硬性规定,否则没有必要对每种组件的所有参数进行测试。

TI 对应用帮助或客户产品设计不承担任何义务。客户应对其使用 TI 组件的产品和应用自行负责。为尽量减小与客户产品和应用相关的风险,客户应提供充分的设计与操作安全措施。

TI 不对任何 TI 专利权、版权、屏蔽作品权或其它与使用了 TI 组件或服务的组合设备、机器或流程相关的 TI 知识产权中授予的直接或隐含权限作出任何保证或解释。TI 所发布的与第三方产品或服务有关的信息,不能构成从 TI 获得使用这些产品或服务的许可、授权、或认可。使用此类信息可能需要获得第三方的专利权或其它知识产权方面的许可,或是 TI 的专利权或其它知识产权方面的许可。

对于 TI 的产品手册或数据表中 TI 信息的重要部分,仅在没有对内容进行任何篡改且带有相关授权、条件、限制和声明的情况下才允许进行复制。TI 对此类篡改过的文件不承担任何责任或义务。复制第三方的信息可能需要服从额外的限制条件。

在转售 TI 组件或服务时,如果对该组件或服务参数的陈述与 TI 标明的参数相比存在差异或虚假成分,则会失去相关 TI 组件或服务的所有明示或暗示授权,且这是不正当的、欺诈性商业行为。TI 对任何此类虚假陈述均不承担任何责任或义务。

客户认可并同意,尽管任何应用相关信息或支持仍可能由 TI 提供,但他们将独立负责满足与其产品及其在应用中使用的 TI 产品相关的所有法律、法规和安全相关要求。客户声明并同意,他们具备制定与实施安全措施所需的全部专业技术和知识,可预见故障的危险后果、监测故障及其后果、降低有可能造成人身伤害的故障的发生机率并采取适当的补救措施。客户将全额赔偿因在此类安全关键应用中使用任何 TI 组件而对 TI 及其代理造成的任何损失。

在某些场合中,为了推进安全相关应用有可能对 TI 组件进行特别的促销。TI 的目标是利用此类组件帮助客户设计和创立其特有的可满足适用的功能安全性标准和要求的终端产品解决方案。尽管如此,此类组件仍然服从这些条款。

TI 组件未获得用于 FDA Class III (或类似的生命攸关医疗设备)的授权许可,除非各方授权官员已经达成了专门管控此类使用的特别协议。

只有那些 TI 特别注明属于军用等级或“增强型塑料”的 TI 组件才是设计或专门用于军事/航空应用或环境的。购买者认可并同意,对并非指定面向军事或航空航天用途的 TI 组件进行军事或航空航天方面的应用,其风险由客户单独承担,并且由客户独立负责满足与此类使用相关的所有法律和法规要求。

TI 已明确指定符合 ISO/TS16949 要求的产品,这些产品主要用于汽车。在任何情况下,因使用非指定产品而无法达到 ISO/TS16949 要求, TI 不承担任何责任。

	产品		应用
数字音频	www.ti.com.cn/audio	通信与电信	www.ti.com.cn/telecom
放大器和线性器件	www.ti.com.cn/amplifiers	计算机及周边	www.ti.com.cn/computer
数据转换器	www.ti.com.cn/dataconverters	消费电子	www.ti.com.cn/consumer-apps
DLP® 产品	www.dlp.com	能源	www.ti.com.cn/energy
DSP - 数字信号处理器	www.ti.com.cn/dsp	工业应用	www.ti.com.cn/industrial
时钟和计时器	www.ti.com.cn/clockandtimers	医疗电子	www.ti.com.cn/medical
接口	www.ti.com.cn/interface	安防应用	www.ti.com.cn/security
逻辑	www.ti.com.cn/logic	汽车电子	www.ti.com.cn/automotive
电源管理	www.ti.com.cn/power	视频和影像	www.ti.com.cn/video
微控制器 (MCU)	www.ti.com.cn/microcontrollers		
RFID 系统	www.ti.com.cn/rfidsys		
OMAP应用处理器	www.ti.com/omap		
无线连通性	www.ti.com.cn/wirelessconnectivity	德州仪器在线技术支持社区	www.deyisupport.com

邮寄地址: 上海市浦东新区世纪大道1568号, 中建大厦32楼邮政编码: 200122
Copyright © 2015, 德州仪器半导体技术(上海)有限公司

PACKAGING INFORMATION

Orderable Device	Status (1)	Package Type	Package Drawing	Pins	Package Qty	Eco Plan (2)	Lead finish/ Ball material (6)	MSL Peak Temp (3)	Op Temp (°C)	Device Marking (4/5)	Samples
BQ40Z50RSMR-R1	ACTIVE	VQFN	RSM	32	3000	RoHS & Green	NIPDAU	Level-2-260C-1 YEAR	-40 to 85	BQ40Z50	Samples
BQ40Z50RSMT-R1	ACTIVE	VQFN	RSM	32	250	RoHS & Green	NIPDAU	Level-2-260C-1 YEAR	-40 to 85	BQ40Z50	Samples

(1) The marketing status values are defined as follows:

ACTIVE: Product device recommended for new designs.

LIFEBUY: TI has announced that the device will be discontinued, and a lifetime-buy period is in effect.

NRND: Not recommended for new designs. Device is in production to support existing customers, but TI does not recommend using this part in a new design.

PREVIEW: Device has been announced but is not in production. Samples may or may not be available.

OBSOLETE: TI has discontinued the production of the device.

(2) **RoHS:** TI defines "RoHS" to mean semiconductor products that are compliant with the current EU RoHS requirements for all 10 RoHS substances, including the requirement that RoHS substance do not exceed 0.1% by weight in homogeneous materials. Where designed to be soldered at high temperatures, "RoHS" products are suitable for use in specified lead-free processes. TI may reference these types of products as "Pb-Free".

RoHS Exempt: TI defines "RoHS Exempt" to mean products that contain lead but are compliant with EU RoHS pursuant to a specific EU RoHS exemption.

Green: TI defines "Green" to mean the content of Chlorine (Cl) and Bromine (Br) based flame retardants meet JS709B low halogen requirements of <=1000ppm threshold. Antimony trioxide based flame retardants must also meet the <=1000ppm threshold requirement.

(3) MSL, Peak Temp. - The Moisture Sensitivity Level rating according to the JEDEC industry standard classifications, and peak solder temperature.

(4) There may be additional marking, which relates to the logo, the lot trace code information, or the environmental category on the device.

(5) Multiple Device Markings will be inside parentheses. Only one Device Marking contained in parentheses and separated by a "~" will appear on a device. If a line is indented then it is a continuation of the previous line and the two combined represent the entire Device Marking for that device.

(6) Lead finish/Ball material - Orderable Devices may have multiple material finish options. Finish options are separated by a vertical ruled line. Lead finish/Ball material values may wrap to two lines if the finish value exceeds the maximum column width.

Important Information and Disclaimer:The information provided on this page represents TI's knowledge and belief as of the date that it is provided. TI bases its knowledge and belief on information provided by third parties, and makes no representation or warranty as to the accuracy of such information. Efforts are underway to better integrate information from third parties. TI has taken and continues to take reasonable steps to provide representative and accurate information but may not have conducted destructive testing or chemical analysis on incoming materials and chemicals. TI and TI suppliers consider certain information to be proprietary, and thus CAS numbers and other limited information may not be available for release.

In no event shall TI's liability arising out of such information exceed the total purchase price of the TI part(s) at issue in this document sold by TI to Customer on an annual basis.

GENERIC PACKAGE VIEW

RSM 32

VQFN - 1 mm max height

4 x 4, 0.4 mm pitch

PLASTIC QUAD FLATPACK - NO LEAD

This image is a representation of the package family, actual package may vary.
Refer to the product data sheet for package details.



4224982/A

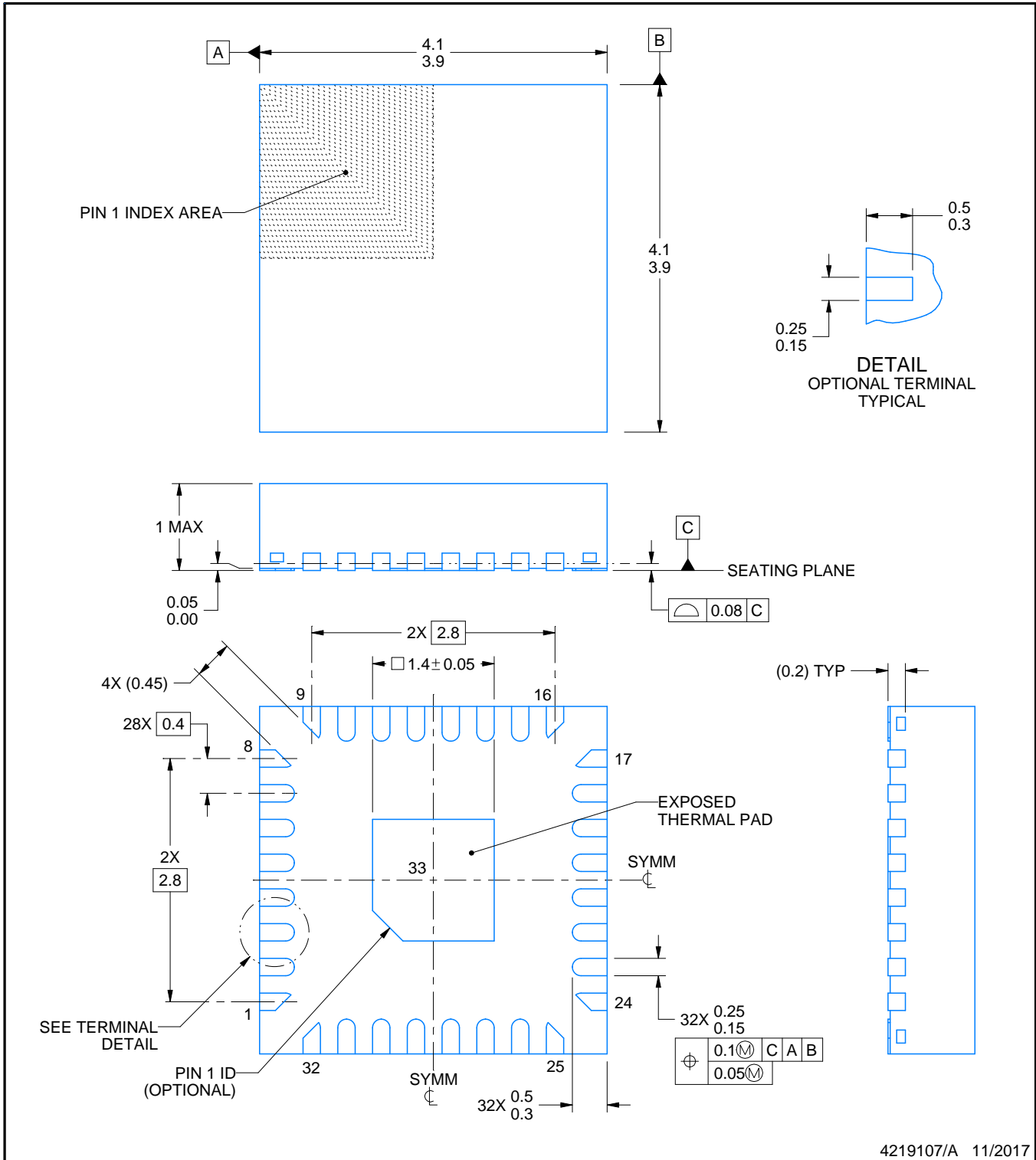
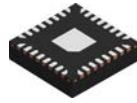

NOTES:

1. All linear dimensions are in millimeters. Any dimensions in parenthesis are for reference only. Dimensioning and tolerancing per ASME Y14.5M.
2. This drawing is subject to change without notice.
3. The package thermal pad must be soldered to the printed circuit board for thermal and mechanical performance.

EXAMPLE BOARD LAYOUT

RSM0032A

VQFN - 1 mm max height

PLASTIC QUAD FLATPACK - NO LEAD

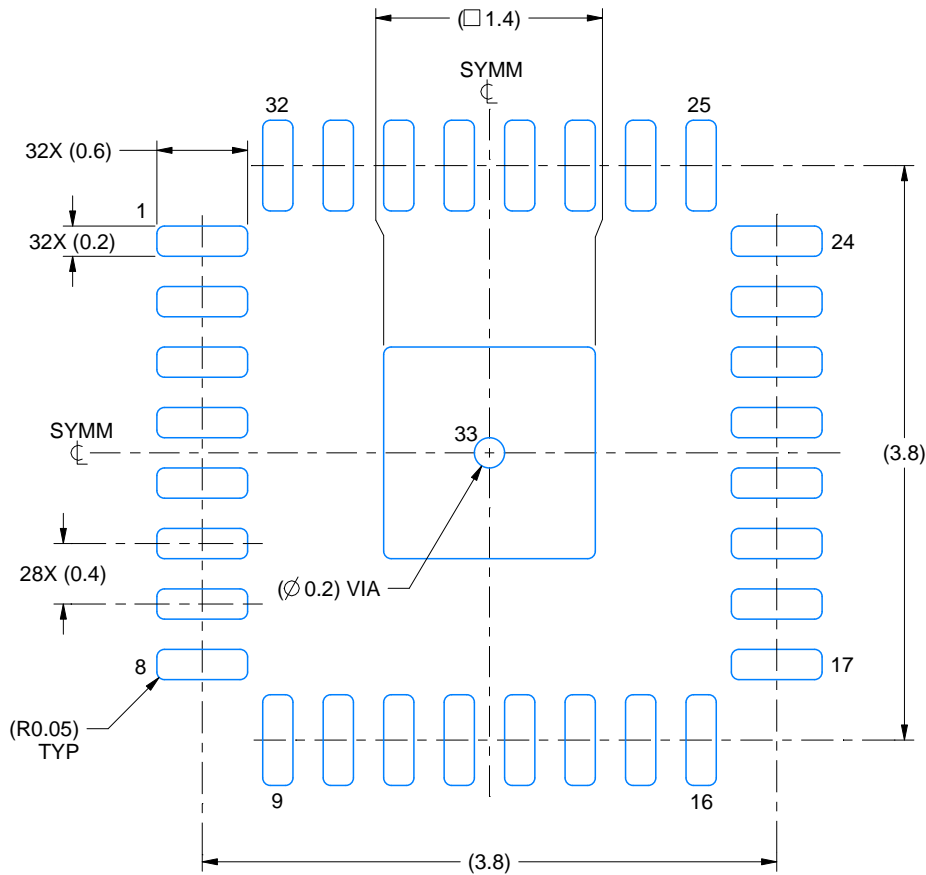

LAND PATTERN EXAMPLE
EXPOSED METAL SHOWN
SCALE:20X

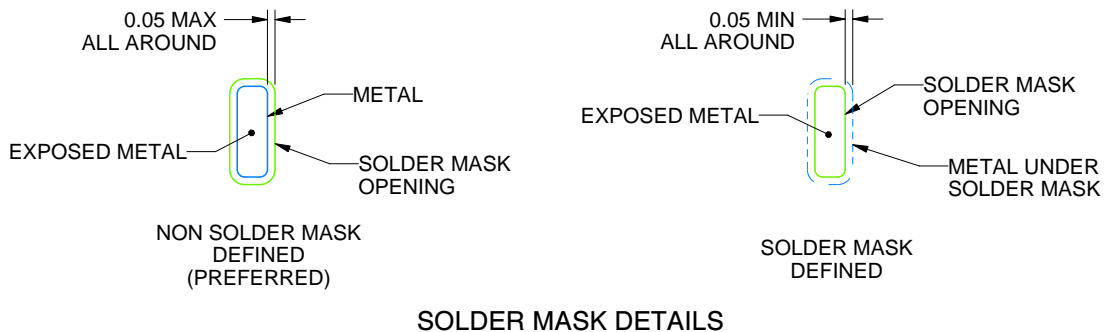

SOLDER MASK DETAILS

4219107/A 11/2017

NOTES: (continued)

- This package is designed to be soldered to a thermal pad on the board. For more information, see Texas Instruments literature number SLUA271 (www.ti.com/lit/sluea271).
- Vias are optional depending on application, refer to device data sheet. If any vias are implemented, refer to their locations shown on this view. It is recommended that vias under paste be filled, plugged or tented.

EXAMPLE STENCIL DESIGN

RSM0032A

VQFN - 1 mm max height

PLASTIC QUAD FLATPACK - NO LEAD

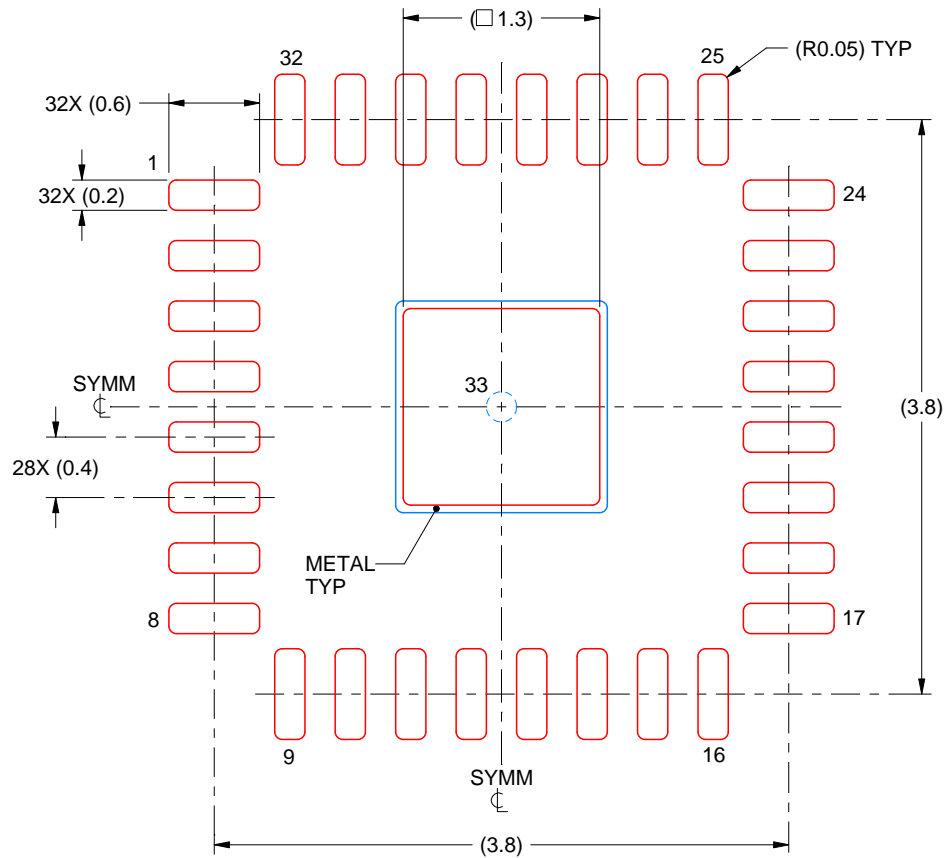

SOLDER PASTE EXAMPLE
BASED ON 0.1 mm THICK STENCIL

EXPOSED PAD 33:
86% PRINTED SOLDER COVERAGE BY AREA UNDER PACKAGE
SCALE:20X

4219107/A 11/2017

NOTES: (continued)

6. Laser cutting apertures with trapezoidal walls and rounded corners may offer better paste release. IPC-7525 may have alternate design recommendations.

重要声明和免责声明

TI 均以“原样”提供技术性及其可靠性数据（包括数据表）、设计资源（包括参考设计）、应用或其他设计建议、网络工具、安全信息和其他资源，不保证其中不含任何瑕疵，且不做任何明示或暗示的担保，包括但不限于对适销性、适合某特定用途或不侵犯任何第三方知识产权的暗示担保。

所述资源可供专业开发人员应用TI 产品进行设计使用。您将对以下行为独自承担全部责任：(1) 针对您的应用选择合适的TI 产品；(2) 设计、验证并测试您的应用；(3) 确保您的应用满足相应标准以及任何其他安全、安保或其他要求。所述资源如有变更，恕不另行通知。TI 对您使用所述资源的授权仅限于开发资源所涉及TI 产品的相关应用。除此之外不得复制或展示所述资源，也不提供其它TI 或任何第三方的知识产权授权许可。如因使用所述资源而产生任何索赔、赔偿、成本、损失及债务等，TI 对此概不负责，并且您须赔偿由此对TI 及其代表造成的损害。

TI 所提供产品均受TI 的销售条款 (<http://www.ti.com.cn/zh-cn/legal/termsofsale.html>) 以及ti.com.cn 上或随附TI 产品提供的其他可适用条款的约束。TI 提供所述资源并不扩展或以其他方式更改TI 针对TI 产品所发布的可适用的担保范围或担保免责声明。

邮寄地址：上海市浦东新区世纪大道 1568 号中建大厦 32 楼，邮政编码：200122

Copyright © 2020 德州仪器半导体技术（上海）有限公司