

DLP4621-Q1 0.46 英寸 0.9 百万像素数字微镜器件（适用于汽车外部照明）

1 特性

- 符合汽车应用要求
 - DMD 阵列工作温度范围 -40°C 至 105°C
- DLP4621-Q1 汽车芯片组包括：
 - DLP4621-Q1 DMD
 - DLPC230-Q1 DMD 控制器
 - TPS99001-Q1 系统管理和照明控制器
- 0.46 英寸对角线微镜阵列
 - 7.6 μm 微镜间距
 - $\pm 12^\circ$ 微镜倾斜角（相对于平面）
 - Bottom 照明可实现高效率 and 更小的发动机尺寸
 - 0.9 百万像素阵列（960 × 960，2:1），支持高分辨率和宽宽高比汽车类应用
 - 与 LED 或激光照明兼容
- 600MHz subLVDS DMD 接口，可实现低功耗和低排放
- 温度极值下 DMD 刷新率为 10 kHz
- DMD 存储器单元的内置自检 (BIST)

2 应用

- 高分辨率前照灯
- 激光雷达光学滤波器
- 符号投影
- 个性化

3 说明

DLP4621-Q1 汽车数字微镜器件 (DMD) 与 DLPC230-Q1 DMD 控制器和 TPS99001-Q1 系统管理和照明控制器结合使用，能够实现具有高性能、高分辨率的前照灯系统。采用 2:1 宽高比，支持超宽宽高比设计；具有 0.9 百万像素分辨率，支持高分辨率符号投影和自适应远光灯应用。DLP4621-Q1 的光通量经过优化，可利用业内出色的 LED 和激光技术更大限度地提高流明。DLP4621-Q1 汽车 DMD 微镜阵列针对底部照明而配置，可实现更高效率以及更紧凑的光学引擎设计。DLP4621-Q1 器件采用面板封装，可优化系统成本。该封装针对 DMD 阵列而言具有低热阻的特点，可实现高效的散热解决方案。

器件信息

器件型号	封装 ^{(1) (2)}	封装尺寸 (标称值)
DLP4621-Q1	FQX	25.2 mm × 11.0 mm

- 如需了解所有可用封装，请参阅数据表末尾的可订购产品附录。
- 本数据表包含了有关此 DMD 在前照灯应用中的规格以及应用信息。有关抬头显示规格和应用的信息，请参阅 *DLP4620S-Q1 数据表 (DLPS230)*。

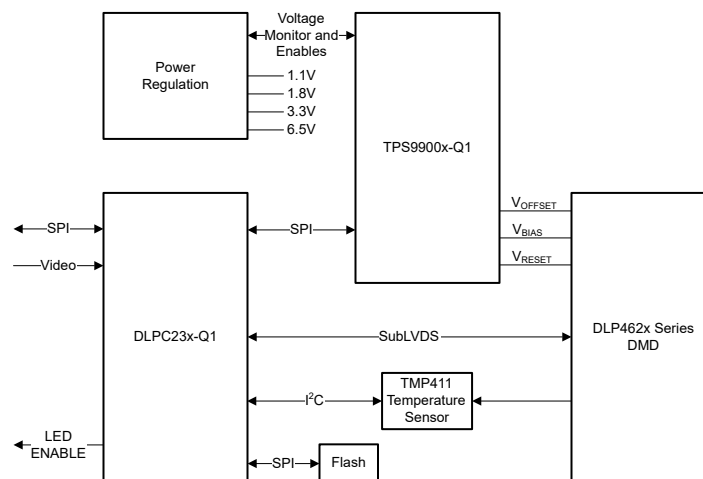

DLP4621-Q1 DLP® 芯片组系统方框图



Table of Contents

1 特性	1	7.4 System Optical Considerations.....	20
2 应用	1	7.5 DMD Image Performance Specification.....	21
3 说明	1	7.6 Micromirror Array Temperature Calculation.....	22
4 Revision History	2	7.7 Micromirror Landed-On/Landed-Off Duty Cycle.....	24
5 Pin Configuration and Functions	3	8 Application and Implementation	26
6 Specifications	8	8.1 Application Information.....	26
6.1 Absolute Maximum Ratings.....	8	8.2 Typical Application.....	26
6.2 Storage Conditions.....	8	9 Power Supply Recommendations	30
6.3 ESD Ratings.....	9	9.1 Power Supply Power-Up Procedure.....	30
6.4 Recommended Operating Conditions.....	9	9.2 Power Supply Power-Down Procedure.....	30
6.5 Thermal Information.....	10	9.3 Power Supply Sequencing Requirements.....	31
6.6 Electrical Characteristics.....	10	10 Layout	32
6.7 Timing Requirements.....	11	10.1 Layout Guidelines.....	32
6.8 Switching Characteristics.....	14	11 Device and Documentation Support	33
6.9 System Mounting Interface Loads.....	15	11.1 第三方产品免责声明.....	33
6.10 Physical Characteristics of the Micromirror Array ..	15	11.2 Device Support.....	33
6.11 Micromirror Array Optical Characteristics	17	11.3 Trademarks.....	33
6.12 Window Characteristics.....	17	11.4 静电放电警告.....	33
6.13 Chipset Component Usage Specification.....	17	11.5 DMD Handling.....	34
7 Detailed Description	18	11.6 术语表.....	34
7.1 Overview.....	18	12 Mechanical, Packaging, and Orderable Information	34
7.2 Functional Block Diagram.....	18		
7.3 Feature Description.....	19		

4 Revision History

DATE	REVISION	NOTES
December 2022	*	Advance Information

5 Pin Configuration and Functions



图 5-1. FQX Package 120-Pin LGA Bottom View

表 5-1. Pin Functions—Connector Pins

PIN		TYPE	SIGNAL	DATA RATE	DESCRIPTION
NAME	NO.				
DATA INPUTS					
D_AN(0)	A3	I	SubLVDS	Double	Data, Negative
D_AN(1)	B1	I	SubLVDS	Double	Data, Negative
D_AN(2)	C2	I	SubLVDS	Double	Data, Negative
D_AN(3)	F2	I	SubLVDS	Double	Data, Negative
D_AN(4)	H2	I	SubLVDS	Double	Data, Negative
D_AN(5)	K1	I	SubLVDS	Double	Data, Negative
D_AN(6)	K4	I	SubLVDS	Double	Data, Negative
D_AN(7)	K6	I	SubLVDS	Double	Data, Negative
D_AP(0)	A2	I	SubLVDS	Double	Data, Positive
D_AP(1)	C1	I	SubLVDS	Double	Data, Positive
D_AP(2)	D2	I	SubLVDS	Double	Data, Positive
D_AP(3)	E2	I	SubLVDS	Double	Data, Positive
D_AP(4)	G2	I	SubLVDS	Double	Data, Positive
D_AP(5)	K2	I	SubLVDS	Double	Data, Positive
D_AP(6)	K3	I	SubLVDS	Double	Data, Positive
D_AP(7)	K5	I	SubLVDS	Double	Data, Positive
D_BN(0)	A22	I	SubLVDS	Double	Data, Negative
D_BN(1)	B24	I	SubLVDS	Double	Data, Negative
D_BN(2)	D23	I	SubLVDS	Double	Data, Negative
D_BN(3)	F23	I	SubLVDS	Double	Data, Negative
D_BN(4)	H23	I	SubLVDS	Double	Data, Negative

表 5-1. Pin Functions—Connector Pins (continued)

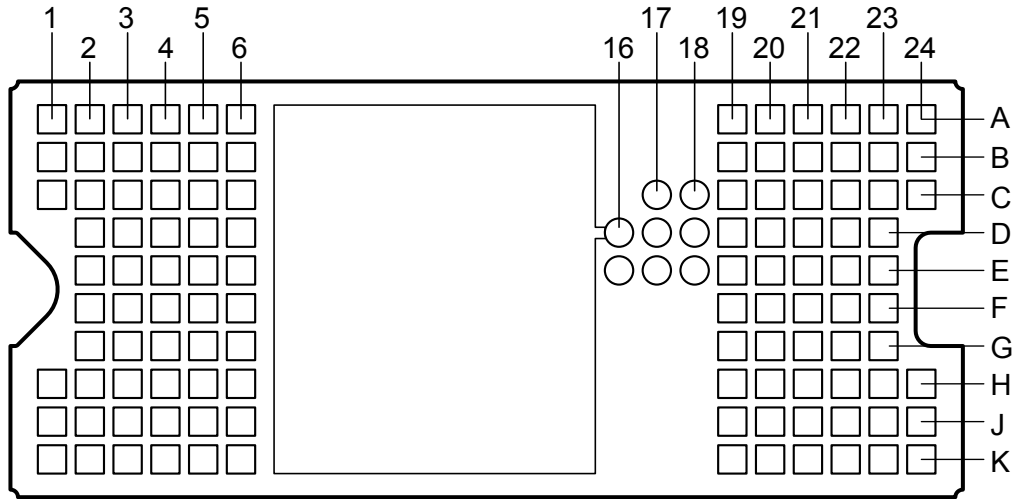
PIN		TYPE	SIGNAL	DATA RATE	DESCRIPTION
NAME	NO.				
D_BN(5)	K24	I	SubLVDS	Double	Data, Negative
D_BN(6)	K21	I	SubLVDS	Double	Data, Negative
D_BN(7)	K19	I	SubLVDS	Double	Data, Negative
D_BP(0)	A23	I	SubLVDS	Double	Data, Positive
D_BP(1)	C24	I	SubLVDS	Double	Data, Positive
D_BP(2)	C23	I	SubLVDS	Double	Data, Positive
D_BP(3)	E23	I	SubLVDS	Double	Data, Positive
D_BP(4)	G23	I	SubLVDS	Double	Data, Positive
D_BP(5)	K23	I	SubLVDS	Double	Data, Positive
D_BP(6)	K22	I	SubLVDS	Double	Data, Positive
D_BP(7)	K20	I	SubLVDS	Double	Data, Positive
DCLK_AN	J1	I	SubLVDS	Double	Clock, Negative
DCLK_AP	H1	I	SubLVDS	Double	Clock, Positive
DCLK_BN	J24	I	SubLVDS	Double	Clock, Negative
DCLK_BP	H24	I	SubLVDS	Double	Clock, Positive
LS_CLKN	C3	I	SubLVDS	Single	Clock for Low Speed Interface, Negative
LS_CLKP	C4	I	SubLVDS	Single	Clock for Low Speed Interface, Positive
LS_WDATAN	C5	I	SubLVDS	Single	Write Data for Low Speed Interface, Negative
LS_WDATAP	C6	I	SubLVDS	Single	Write Data for Low Speed Interface, Positive
CONTROL INPUTS					
DMD_DEN_ARSTZ	E6	I	LPSDR		Asynchronous Reset Active Low. Logic High Enables DMD
LS_RDATA_A	E19	O	LPSDR	Single	Read Data for Low Speed Interface
LS_RDATA_B	F19	O	LPSDR	Single	Read Data for Low Speed Interface
TEMPERATURE SENSE DIODE					
TEMP_N	F6	O			Calibrated temperature diode used to assist accurate temperature measurements of DMD die
TEMP_P	G6	I			

表 5-1. Pin Functions—Connector Pins (continued)

PIN		TYPE	SIGNAL	DATA RATE	DESCRIPTION
NAME	NO.				
POWER					
VBIAS	A4	Power			Supply voltage for positive bias level at micromirrors
VBIAS	A21	Power			
VOFFSET	B3	Power			Supply voltage for high-voltage CMOS core logic. Supply voltage for offset level at micromirrors
VOFFSET	B4	Power			
VOFFSET	B21	Power			
VOFFSET	B22	Power			
VOFFSET	J4	Power			
VOFFSET	J21	Power			
VRESET	B6	Power			Supply voltage for negative reset level at micromirrors
VRESET	B19	Power			
VDD	A5	Power			Supply voltage for Low Voltage CMOS core logic; for LPSDR inputs; for normal high level at micromirror address electrodes
VDD	A20	Power			
VDD	C20	Power			
VDD	D4	Power			
VDD	D19	Power			
VDD	D21	Power			
VDD	E3	Power			
VDD	E22	Power			
VDD	F4	Power			
VDD	G3	Power			
VDD	G21	Power			
VDD	H22	Power			
VDD	J3	Power			
VDD	J6	Power			
VDD	J19	Power			
VDDI	E5	Power			
VDDI	E20	Power			
VDDI	F5	Power			
VDDI	F20	Power			
VDDI	G5	Power			
VDDI	G20	Power			
VDDI	H5	Power			
VDDI	H20	Power			

ADVANCE INFORMATION

表 5-1. Pin Functions—Connector Pins (continued)

PIN		TYPE	SIGNAL	DATA RATE	DESCRIPTION
NAME	NO.				
VSS	A1	Ground			Common return. Ground for all power
VSS	A6	Ground			
VSS	A19	Ground			
VSS	A24	Ground			
VSS	B2	Ground			
VSS	B5	Ground			
VSS	B20	Ground			
VSS	B23	Ground			
VSS	C19	Ground			
VSS	C21	Ground			
VSS	C22	Ground			
VSS	D3	Ground			
VSS	D5	Ground			
VSS	D6	Ground			
VSS	D20	Ground			
VSS	D22	Ground			
VSS	E4	Ground			
VSS	E21	Ground			
VSS	F3	Ground			
VSS	F21	Ground			
VSS	F22	Ground			
VSS	G4	Ground			
VSS	G19	Ground			
VSS	G22	Ground			
VSS	H3	Ground			
VSS	H4	Ground			
VSS	H6	Ground			
VSS	H19	Ground			
VSS	H21	Ground			
VSS	J2	Ground			
VSS	J5	Ground			
VSS	J20	Ground			
VSS	J22	Ground			
VSS	J23	Ground			

表 5-2. Pin Functions—Test Pads

NUMBER	SYSTEM BOARD
TP0	Do not connect.
TP1	Do not connect.
TP2	Do not connect.
MBRST(0)	Do not connect.
MBRST(1)	Do not connect.
MBRST(6)	Do not connect.
MBRST(7)	Do not connect.

6 Specifications

6.1 Absolute Maximum Ratings

Operation outside the Absolute Maximum Ratings may cause permanent device damage. Absolute Maximum Ratings do not imply functional operation of the device at these or any other conditions beyond those listed under Recommended Operating Conditions. If outside the Recommended Operating Conditions but within the Absolute Maximum Ratings, the device may not be fully functional, and this may affect device reliability, functionality, performance, and shorten the device lifetime.

		MIN	MAX	UNIT
SUPPLY VOLTAGE				
V_{DD}	Supply voltage for LVCMOS core logic ⁽¹⁾ Supply voltage for LPSDR low speed interface	- 0.5	2.3	V
V_{DDI}	Supply voltage for subLVDS receivers ⁽¹⁾	- 0.5	2.3	V
V_{OFFSET}	Supply voltage for HVCMOS and micromirror electrode ^{(1) (2)}	- 0.5	8.75	V
V_{BIAS}	Supply voltage for micromirror electrode ⁽¹⁾	- 0.5	17	V
V_{RESET}	Supply voltage for micromirror electrode ⁽¹⁾	- 11	0.5	V
$ V_{DDI} - V_{DD} $	Supply voltage delta (absolute value) ⁽³⁾		0.3	V
$ V_{BIAS} - V_{OFFSET} $	Supply voltage delta (absolute value) ⁽⁴⁾		8.75	V
$ V_{BIAS} - V_{RESET} $	Supply voltage delta (absolute value) ⁽⁵⁾		28	V
INPUT VOLTAGE				
Input voltage for LVCMOS inputs ⁽¹⁾		- 0.5	$V_{DD} + 0.5$	V
Input voltage for other inputs subLVDS ^{(1) (6)}		- 0.5	$V_{DDI} + 0.5$	V
INPUT PINS				
$ V_{ID} $	SubLVDS input differential voltage (absolute value) ⁽⁶⁾		810	mV
$ I_{ID} $	SubLVDS input differential current		10	mA
CLOCK FREQUENCY				
F_{max_LS}	Clock frequency for low speed interface LS_CLK	100	130	MHz
TEMPERATURE DIODE				
I_{TEMP_DIODE}	Max current source into temperature diode		120	μ A
ENVIRONMENTAL				
T_{ARRAY}	Operating DMD array temperature	- 40	105	$^{\circ}$ C

- (1) All voltage values are with respect to the ground terminals (VSS). The following power supplies are all required to operate the DMD: VDD, VDDI, VOFFSET, VBIAS, and VRESET. All VSS connections are also required.
- (2) VOFFSET supply transients must fall within specified voltages.
- (3) Exceeding the recommended allowable absolute voltage difference between VDDI and VDD may result in excessive current draw and permanent damage to the device.
- (4) Exceeding the recommended allowable absolute voltage difference between VBIAS and VOFFSET may result in excessive current draw and permanent damage to the device.
- (5) Exceeding the recommended allowable absolute voltage difference between VBIAS and VRESET may result in excessive current draw and permanent damage to the device.
- (6) This maximum input voltage rating applies when each input of a differential pair is at the same voltage potential. SubLVDS differential inputs must not exceed the specified limit or damage to the internal termination resistors may result.

6.2 Storage Conditions

Applicable for the DMD as a component or non-operating in a system.

		MIN	MAX	UNIT
T_{stg}	DMD storage temperature	- 40	125	$^{\circ}$ C

6.3 ESD Ratings

		VALUE	UNIT
V _(ESD)	Electrostatic discharge	Human body model (HBM), per AEC Q100-002 ⁽¹⁾	±2000
		Charged device model (CDM), per AEC Q100-011	±750

(1) AEC Q100-002 indicates that HBM stressing shall be in accordance with the ANSI/ESDA/JEDEC JS-001 specification.

6.4 Recommended Operating Conditions

Over operating free-air temperature range (unless otherwise noted)^{(1) (2)}

		MIN	NOM	MAX	UNIT
SUPPLY VOLTAGE					
V _{DD}	Supply voltage for LVCMOS core logic Supply voltage for LPSDR low-speed interface	1.65	1.8	1.95	V
V _{DDI}	Supply voltage for SubLVDS receivers	1.65	1.8	1.95	V
V _{OFFSET}	Supply voltage for HVCMOS and micromirror electrode ⁽³⁾	8.25	8.5	8.75	V
V _{BIAS}	Supply voltage for mirror electrode	15.5	16	16.5	V
V _{RESET}	Supply voltage for micromirror electrode	- 9.5	- 10	- 10.5	V
V _{DDI} - V _{DD}	Supply voltage delta (absolute value) ⁽⁴⁾			0.3	V
V _{BIAS} - V _{OFFSET}	Supply voltage delta (absolute value) ⁽⁵⁾			8.75	V
V _{BIAS} - V _{RESET}	Supply voltage delta (absolute value) ⁽⁶⁾			28	V
LOW-SPEED LPSDR INTERFACE					
f _{clock_LS}	Clock frequency for low speed interface LS_CLK	108		120	MHz
DCD _{IN}	LSIF duty cycle distortion (LS_CLK)	44		56	%
SUBLVDS INTERFACE					
f _{clock_HS}	Clock frequency for high-speed interface DCLK	300		540	MHz
DCD _{IN}	LVDS duty cycle distortion (DCLK)	44		56	%
V _{ID}	LVDS differential input voltage magnitude ⁽⁷⁾	150	250	350	mV
V _{CM}	Common mode voltage ⁽⁷⁾	700	900	1100	mV
V _{SUBLVDS}	SubLVDS voltage ⁽⁷⁾	525		1275	mV
Z _{LINE}	Line differential impedance (PWB/trace)	90	100	110	Ω
Z _{IN}	Internal differential termination resistance ⁽⁸⁾	80	100	120	Ω
	100-Ω differential PCD trace	6.35		152.4	mm
ENVIRONMENTAL					
T _{ARRAY}	Array Temperature ^{(9) (11)}	-40		105	°C
Illumination					
ILL _{UV}	Illumination, wavelength < 395 nm ⁽¹⁰⁾			2	mW/cm ²
ILL _{OVERFILL}	Illumination overfill maximum heat load in area shown in Figure 6-1			90	mW/mm ²

- (1) Recommended Operating Conditions are applicable after the DMD is installed in the final product.
- (2) The following power supplies are all required to operate the DMD: VDD, VDDI, VOFFSET, VBIAS, and VRESET. All VSS connections are also required.
- (3) VOFFSET supply transients must fall within specified min/max voltages.
- (4) To prevent excess current, the supply voltage delta |VDDI - VDD| must be less than the specified limit.
- (5) To prevent excess current, the supply voltage delta |VBIAS - VOFFSET| must be less than the specified limit.
- (6) To prevent excess current, the supply voltage delta |VBIAS - VRESET| must be less than the specified limit.
- (7) See Figure 6-6 and Figure 6-7.
- (8) See Figure 6-8.
- (9) DMD Active Array temperature can be calculated as shown in the *Micromirror Array Temperature Calculation*.
- (10) The maximum operation conditions for operating temperature and UV illumination must not be implemented simultaneously.
- (11) The operating profile information for the device micromirror landed duty-cycle and temperature is provided upon request.

6.4.1 Illumination Overfill Diagram



图 6-1. Illumination Overfill Diagram

6.5 Thermal Information

THERMAL METRIC		DLP4621-Q1	
		FQX	UNIT
		120 Pins	
Thermal resistance	Active area-to-test point 1 (TP1) ⁽¹⁾ ⁽²⁾	1.5	°C/W
Thermal resistance	Active area-to-temperature sense diode ⁽¹⁾ ⁽²⁾	0.5	°C/W

- (1) The DMD is designed to conduct absorbed and dissipated heat to the back of the package. The cooling system must be capable of maintaining the package within the temperature range specified in the *Recommended Operating Conditions*. The total heat load on the DMD is largely driven by the incident light absorbed by the active area, although other contributions include light energy absorbed by the window aperture and electrical power dissipation of the array. Optical systems should be designed to minimize the light energy falling outside the window clear aperture since any additional thermal load in this area can significantly degrade the reliability of the device.
- (2) The thermal resistance values provided here assumes a non-uniform illumination profile. Refer to *Micromirror Array Temperature Calculation* for details.

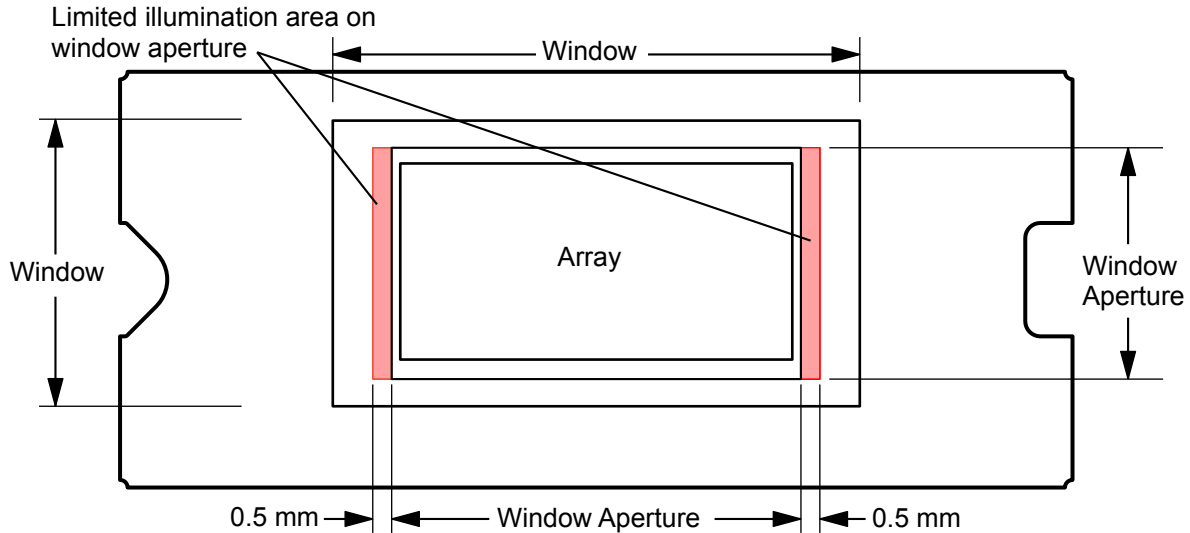
6.6 Electrical Characteristics

Over operating free-air temperature range (unless otherwise noted) ⁽¹⁾

PARAMETER		TEST CONDITIONS	MIN	TYP	MAX	UNIT
CURRENT						
I_{DD}	Supply current: VDD ⁽²⁾	VDD = 1.95 V			220	mA
I_{DDI}	Supply current: VDDI ⁽²⁾	VDDI = 1.95 V			55	mA
I_{OFFSET}	Supply current: VOFFSET	VOFFSET = 8.75 V			35	mA
I_{BIAS}	Supply current: VBIAS	VBIAS = 16.5 V			1.5	mA
I_{RESET}	Supply current: VRESET	VRESET = - 10.5 V			16	mA
POWER						
P_{DD}	Supply power dissipation: VDD ⁽²⁾	VDD = 1.95 V			430	mW
P_{DDI}	Supply power dissipation: VDDI ⁽²⁾	VDDI = 1.95 V			108	mW
P_{OFFSET}	Supply power dissipation: VOFFSET	VOFFSET = 8.75 V			307	mW
P_{BIAS}	Supply power dissipation: VBIAS	VBIAS = 16.5 V			25	mW
P_{RESET}	Supply power dissipation: VRESET	VRESET = - 10.5 V			168	mW

6.6 Electrical Characteristics (continued)

Over operating free-air temperature range (unless otherwise noted) ⁽¹⁾

PARAMETER		TEST CONDITIONS	MIN	TYP	MAX	UNIT
P _{TOTAL}	Supply power dissipation: total				1038	mW
LVC MOS INPUT						
V _{IH}	High-level input voltage ⁽³⁾		0.7 × V _{DD}		V _{DD} + 0.3	V
V _{IL}	Low-level input voltage ⁽³⁾		- 0.3		0.3 × V _{DD}	V
V _{IH(AC)}	AC input high voltage ⁽³⁾		0.8 × V _{DD}		V _{DD} + 0.3	V
V _{IL(AC)}	AC input low voltage ⁽³⁾		- 0.3		0.2 × V _{DD}	V
V _{Hyst}	Input hysteresis ⁽³⁾	See Figure 6-9	0.1 × V _{DD}		0.4 × V _{DD}	V
I _{IL}	Low-level input current ⁽³⁾	V _{DD} = 1.95 V; V _I = 0 V	- 100			nA
I _{IH}	High-level input current ⁽³⁾	V _{DD} = 1.95 V; V _I = 1.95 V			135	μA
LVC MOS OUTPUT						
V _{OH}	DC output high voltage ⁽⁴⁾	I _{OH} = - 2 mA	0.8 × V _{DD}			V
V _{OL}	DC output low voltage ⁽⁴⁾	I _{OL} = 2 mA			0.2 × V _{DD}	V
I _{OZ}	High impedance output current	V _{DD} = 1.95 V			10	μA
CAPACITANCE						
C _{IN}	Input capacitance LVC MOS	F = 1 MHz			10	pF
	Input capacitance subLVDS	F = 1 MHz			20	pF
C _{OUT}	Output capacitance	F = 1 MHz			10	pF
C _{TEMP}	Input capacitance subLVDS	F = 1 MHz			20	pF

- (1) Device electrical characteristics are over *Recommended Operating Conditions* unless otherwise noted.
(2) Supply power dissipation based on non-compressed commands and data.
(3) LPSDR input specifications are for pin DMD_DEN_ARSTZ.
(4) LPSDR output specification is for pins LS_RDATA_A and LS_RDATA_B.

6.7 Timing Requirements

Device electrical characteristics are over *Recommended Operating Conditions* unless otherwise noted

			MIN	NOM	MAX	UNIT
Low-Speed Interface						
t _r	Rise slew rate ^{(1) (2)}	(20% to 80%) × V _{DD}	0.25			V/ns
t _f	Fall slew rate ^{(1) (2)}	(80% to 20%) × V _{DD}	0.25			V/ns
t _c	Cycle time LS_CLK		7.7	8.3		ns
t _{W(H)}	Pulse duration LS_CLK high ⁽³⁾	50% to 50% reference points	3.1			ns
t _{W(L)}	Pulse duration LS_CLK low ⁽³⁾	50% to 50% reference points	3.1			ns
t _{su}	Setup time ⁽³⁾	LS_WDATA valid before LS_CLK ↑ or LS_CLK ↓	1.5			ns
t _h	Hold time ⁽³⁾	LS_WDATA valid after LS_CLK ↑ or LS_CLK ↓	1.5			ns
t _{WINDOW}	Window time	Setup time + hold time	3			ns
t _{DERATING}	Window time derating	For each 0.25 V/ns reduction in slew rate below 1 V/ns		0.35		ns
High-Speed Interface						
t _r	Rise slew rate ⁽²⁾	20% to 80% reference points	0.7	1		V/ns
t _f	Fall slew rate ⁽²⁾	80% to 20% reference points	0.7	1		V/ns

6.7 Timing Requirements (continued)

Device electrical characteristics are over *Recommended Operating Conditions* unless otherwise noted

			MIN	NOM	MAX	UNIT
t_c	Cycle time DCLK ⁽³⁾		1.79	1.85		ns
$t_{W(H)}$	Pulse duration DCLK high ⁽³⁾	50% to 50% reference points	0.79			ns
$t_{W(L)}$	Pulse duration DCLK low ⁽³⁾	50% to 50% reference points	0.79			ns
t_{WINDOW}	Window time ⁽³⁾ ⁽⁴⁾	Setup time + Hold time	0.3			ns
$t_{LVDS-EN+REFGEN}$	Power-up receiver ⁽⁵⁾				2000	ns

- (1) Specification is for DMD_DEN_ARSTZ pin. Refer to LPSDR input rise and fall slew rate in Figure 6-2.
- (2) See Figure 6-3.
- (3) See Figure 6-4.
- (4) See Figure 6-5.
- (5) Specification is for SubLVDS receiver time only and does not take into account commanding and latency after commanding.

Electrical and Timing Diagrams



图 6-2. LPSDR Input Rise and Fall Slew Rate



图 6-3. SubLVDS Input Rise and Fall Slew Rate

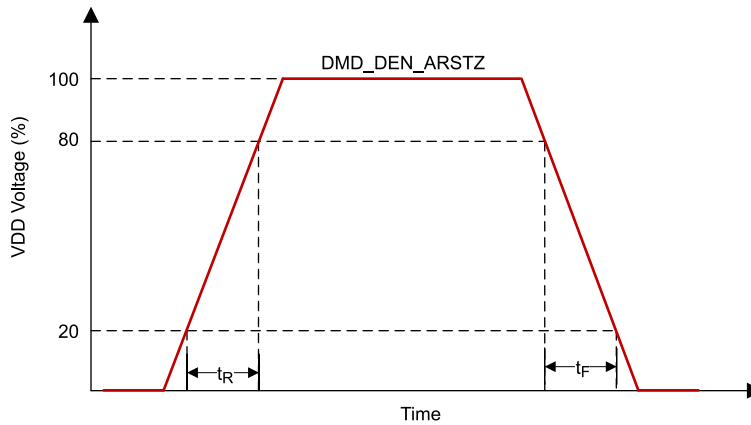

图 6-4. SubLVDS Switching Parameters

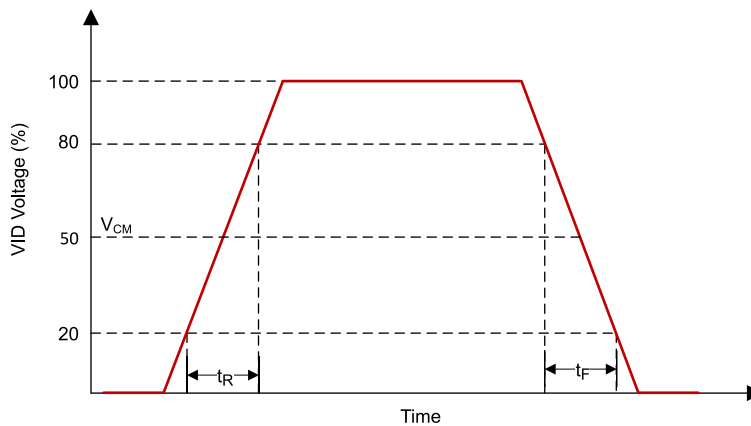

(1) High-speed training scan window

图 6-5. High-Speed Training Scan Window

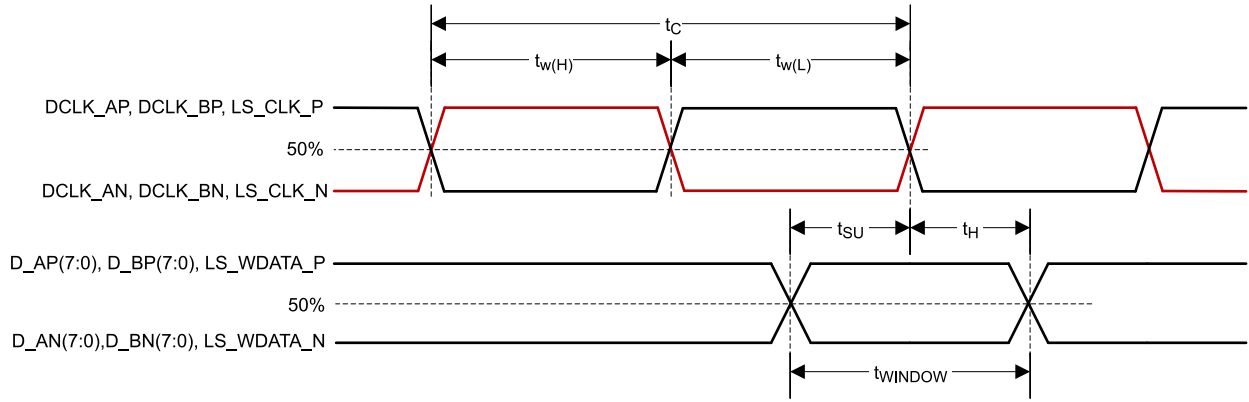
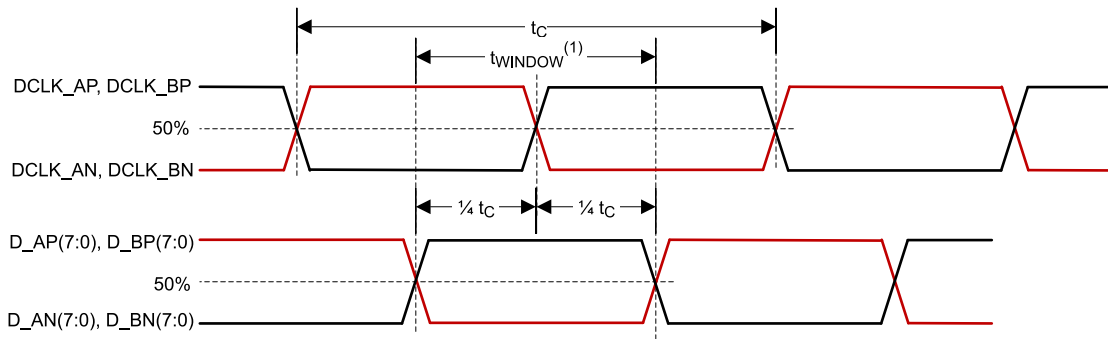

图 6-6. SubLVDS Voltage Parameters



图 6-7. SubLVDS Waveform Parameters

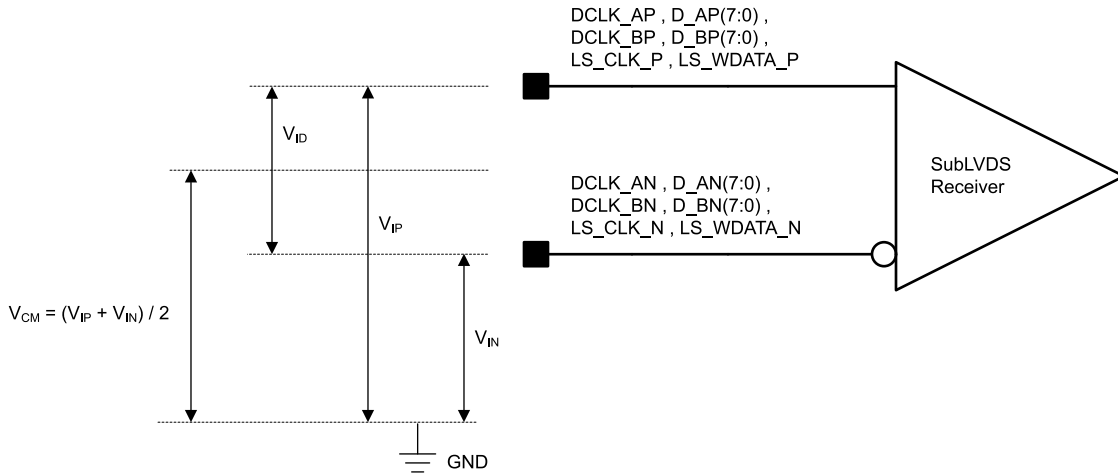

图 6-8. SubLVDS Equivalent Input Circuit

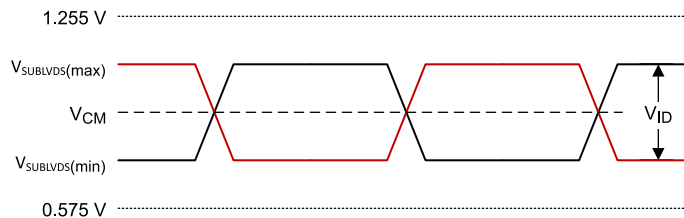

图 6-9. LPSDR Input Hysteresis

6.8 Switching Characteristics

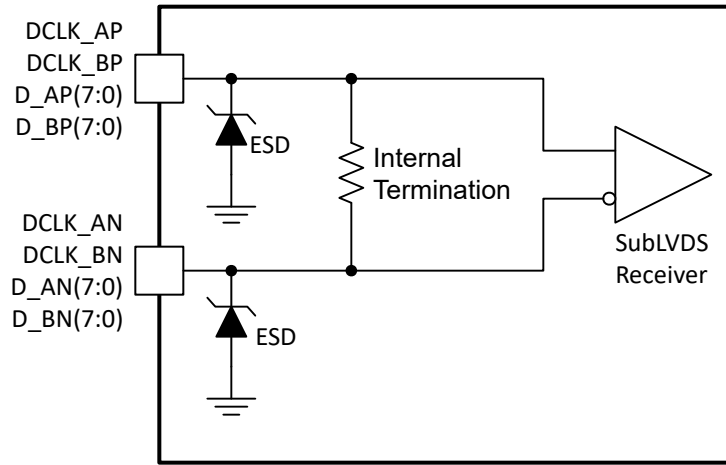
Over operating free-air temperature range (unless otherwise noted)⁽¹⁾

PARAMETER		TEST CONDITIONS	MIN	TYP	MAX	UNIT
t_{PD}	Output propagation, clock to Q, rising edge of LS_CLK (differential clock signal) input to LS_RDATA output ⁽²⁾	$C_L = 45 \text{ pF}$			15	ns
	Slew rate, LS_RDATA		0.5			V/ns
	Output duty cycle distortion, LS_RDATA_A and LS_RDATA_B		40%		60%	

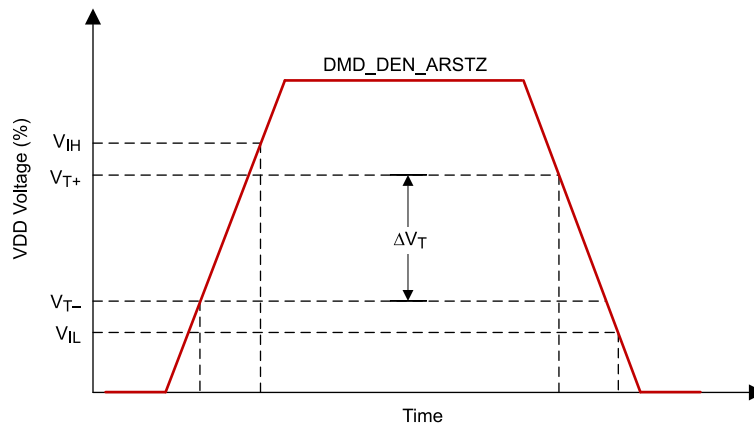
(1) Device electrical characteristics are over *Recommended Operating Conditions* unless otherwise noted.

(2) See 图 6-10 and 图 6-11.

6.8.1 LPSDR and Test Load Circuit Diagrams



图 6-10. LPSDR Read Out



图 6-11. Test Load Circuit for Output Propagation Measurement

6.9 System Mounting Interface Loads

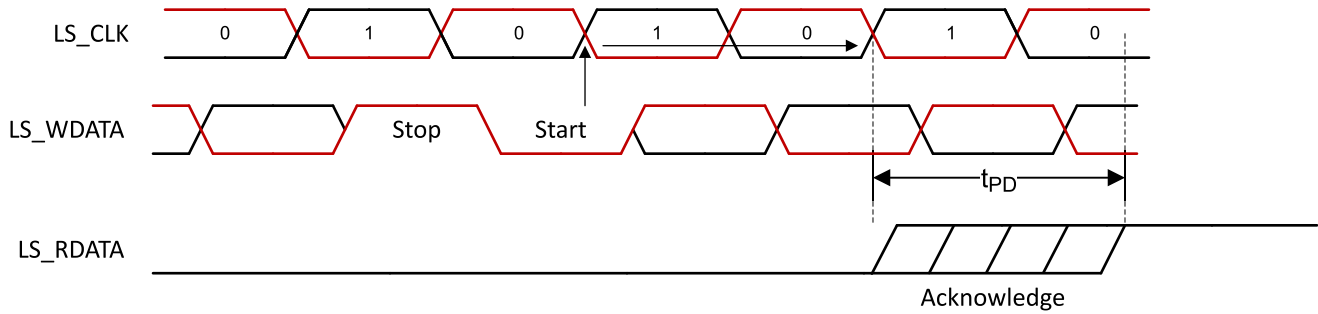
PARAMETER	Condition	MIN	NOM	MAX	UNIT
Thermal interface area	Maximum load uniformly distributed within each area ⁽¹⁾			90	N
Electrical interface area	Maximum load uniformly distributed within each area ⁽¹⁾			135	

(1) See Figure 6-12.

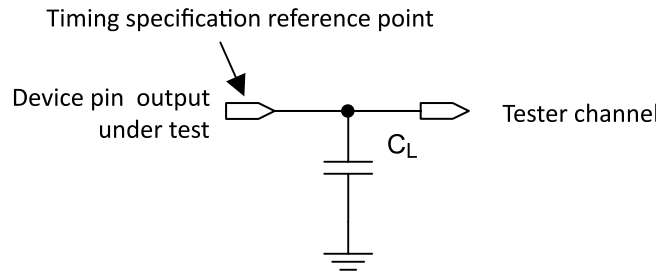
System Interface Loads Diagram



图 6-12. System Interface Loads

6.10 Physical Characteristics of the Micromirror Array

PARAMETER	VALUE	UNIT
M Number of active columns ⁽¹⁾	960	micromirrors
N Number of active rows ⁽¹⁾	960	micromirrors
ϵ Micromirror (pixel) pitch—diagonal ⁽¹⁾	7.6	μm
P Micromirror (pixel) pitch—horizontal and vertical ⁽¹⁾	10.8	μm

6.10 Physical Characteristics of the Micromirror Array (continued)

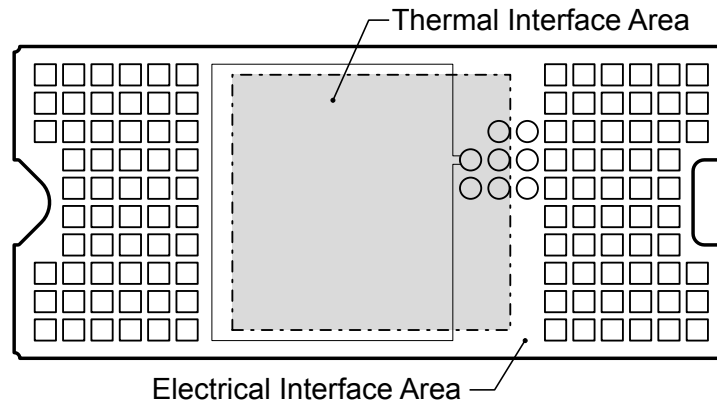
PARAMETER	VALUE	UNIT
Micromirror active array width	$(P \times M) + (P / 2)$	10.373 mm
Micromirror active array height	$(P \times N) / 2 + (P / 2)$	5.189 mm
Micromirror active border	Pond of micromirrors (POM) ⁽²⁾	10 micromirrors/side

- (1) See 图 6-13.
- (2) The structure and qualities of the border around the active array includes a band of partially functional micromirrors called the POM. These micromirrors are structurally and/or electrically prevented from tilting toward the bright or ON state, but still require an electrical bias to tilt toward OFF.

6.10.1 Array Physical Characteristics Diagram

ADVANCE INFORMATION



图 6-13. Micromirror Array Physical Characteristics

6.11 Micromirror Array Optical Characteristics

PARAMETER	TEST CONDITIONS	MIN	NOM	MAX	UNIT
Micromirror tilt angle	DMD landed state ⁽¹⁾		12		degree
Micromirror tilt angle tolerance ⁽²⁾		- 1		1	degree
DMD efficiency ⁽³⁾	420 nm - 700 nm		66%		

- (1) Measured relative to the plane formed by the overall micromirror array at 25°C.
- (2) For some applications, it is critical to account for the micromirror tilt angle variation in the overall optical system design. With some optical system designs, the micromirror tilt angle variation within a device may result in perceivable non-uniformities in the light field reflected from the micromirror array. With some optical system designs, the micromirror tilt angle variation between devices may result in colorimetry variations, system efficiency variations, or system contrast variations.
- (3) DMD efficiency is measured photopically under the following conditions: 24° illumination angle, F/2.4 illumination and collection apertures, uniform source spectrum (halogen), uniform pupil illumination, the optical system is telecentric at the DMD, and the efficiency numbers are measured with 100% electronic micromirror landed duty-cycle and do not include system optical efficiency or overfill loss. This number is measured under conditions described above and deviations from these specified conditions could result in a different efficiency value in a different optical system. The factors that can influence the DMD efficiency related to system application include: light source spectral distribution and diffraction efficiency at those wavelengths (especially with discrete light sources such as LEDs or lasers), and illumination and collection apertures (F/#) and diffraction efficiency. The interaction of these system factors as well as the DMD efficiency factors that are not system dependent are described in detail in [DMD Optical Efficiency for Visible Wavelengths Application Note](#).

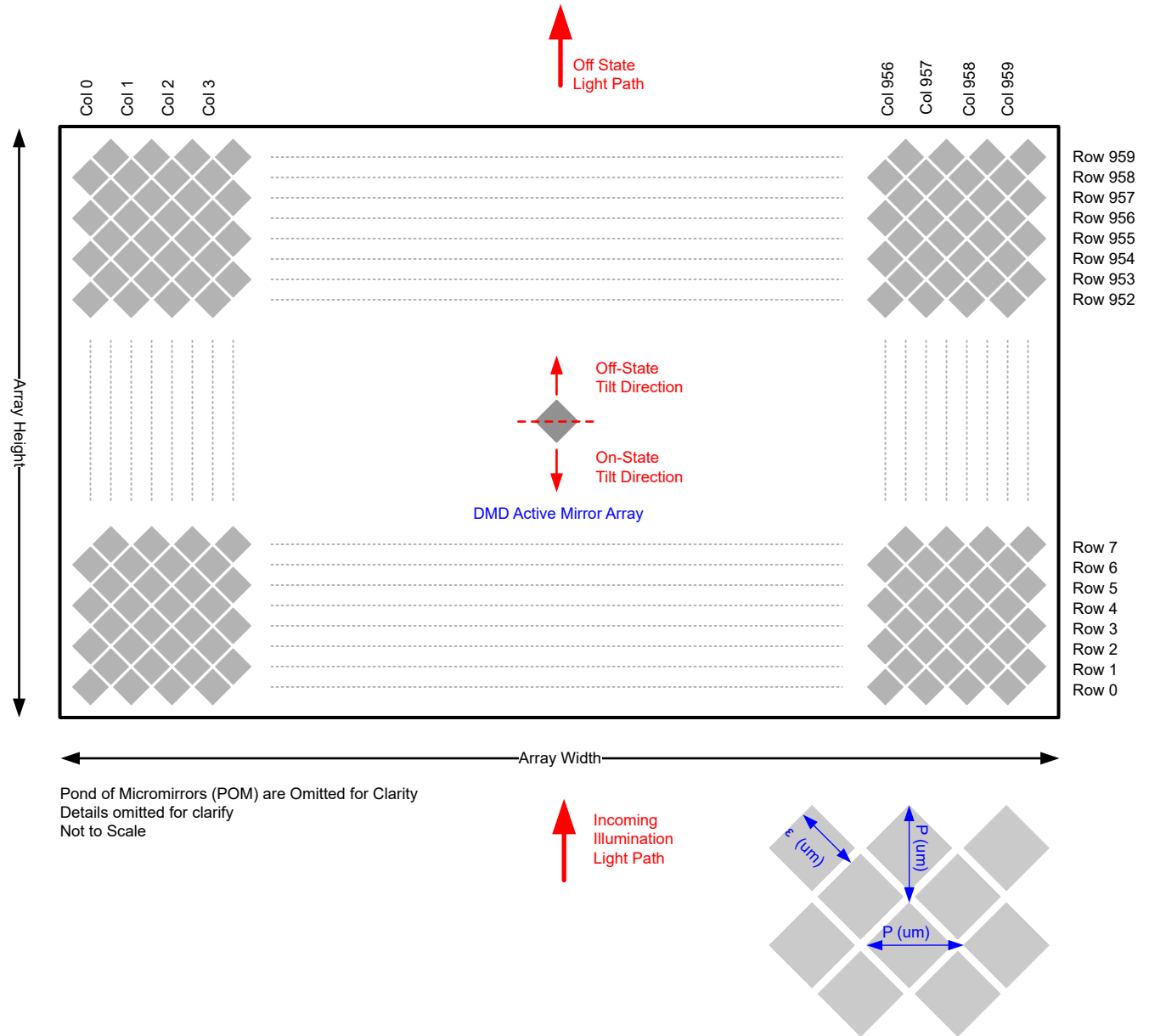
6.12 Window Characteristics

PARAMETER	MIN	NOM	MAX	UNIT
Window material designation	Corning Eagle XG			
Window refractive index	At wavelength 546.1 nm			1.5119
Window aperture ⁽¹⁾				See ⁽¹⁾ .
Illumination overfill				See ⁽¹⁾ .

- (1) See the mechanical package ICD for details regarding the size and location of the window aperture.

6.13 Chipset Component Usage Specification

The DLP4621-Q1 is a component of a chipset. Reliable function and operation of the DLP4621-Q1 requires that it be used in conjunction with the TPS99001-Q1 and DLPC230-Q1, and includes components that contain or implement TI DMD control technology. TI DMD control technology consists of the TI technology and devices used for operating or controlling a DLP DMD.

备注

TI assumes no responsibility for image quality artifacts or DMD failures caused by optical system operating conditions exceeding limits described previously.

7 Detailed Description

7.1 Overview

The DLP4621-Q1 automotive DMD consists of 921600 highly reflective, digitally switchable, micrometer-sized mirrors organized in a two-dimensional array. As shown in [Figure 6-13](#), the micromirror array consists of 960 micromirror columns × 960 micromirror rows in a diamond pixel configuration with a 2:1 aspect ratio.

Around the perimeter of the 960 × 960 array of micromirrors is a uniform band of border micromirrors called the Pond of Micromirrors (POM). The border micromirrors are not user-addressable. The border micromirrors land in the - 12° position once power has been applied to the device. There are 10 border micromirrors on each side of the 960 × 960 active array.

Due to the diamond pixel configuration, the columns of each odd row are offset by half a pixel from the columns of the even row. Each mirror is switchable between two discrete angular positions: - 12° and +12°. The mirrors are illuminated from the bottom which allows for compact and efficient system optical design.

7.2 Functional Block Diagram

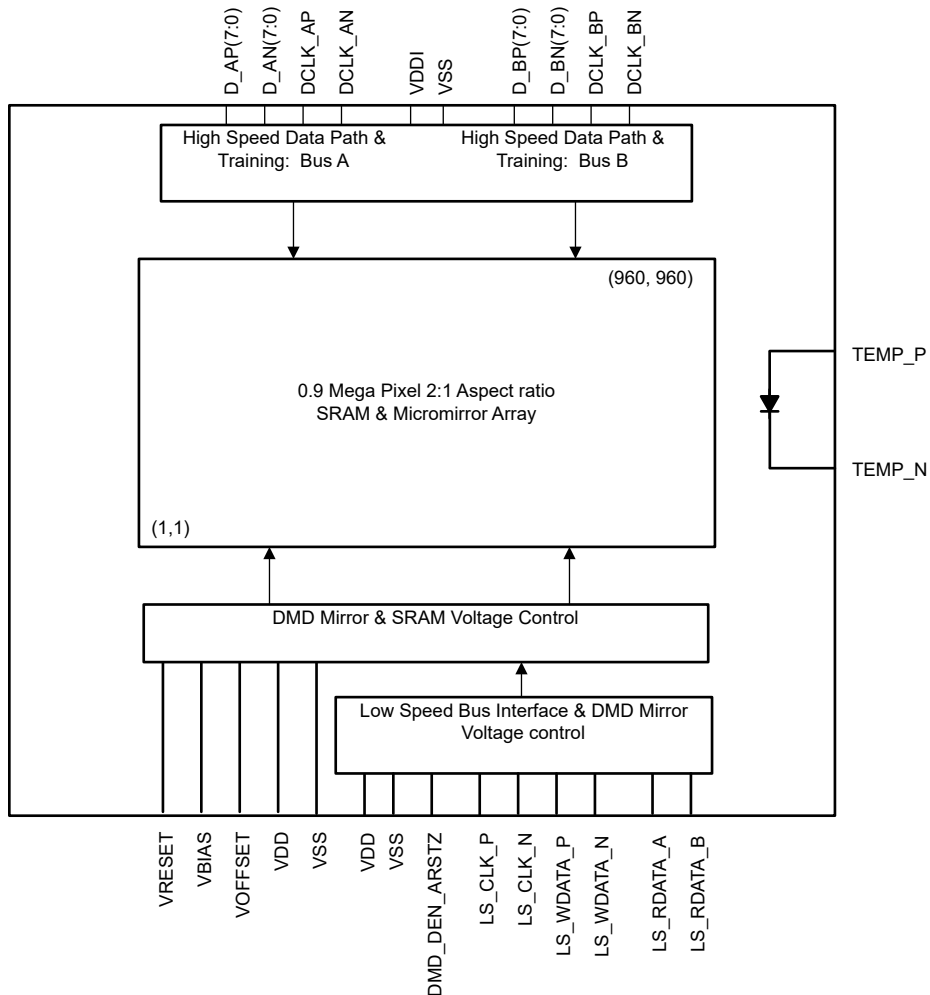

7.3 Feature Description

The DLP4621-Q1 consists of a two-dimensional array of 1-bit CMOS memory cells driven by a subLVDS bus from the DLPC230-Q1 and powered by the TPS99001-Q1. The temperature sensing diode is used to continuously monitor the DMD array temperature.

To ensure reliable operation, the DLP4621-Q1 must be used with the DLPC230-Q1 DMD display controller and the TPS99001-Q1 system management and illumination controller.

7.3.1 SubLVDS Data Interface

The subLVDS signaling protocol was designed to enable very fast DMD data refresh rates while simultaneously maintaining low power and low emission.

Data is loaded into the SRAM under each micromirror using the subLVDS interface from the DLPC230-Q1. This interface consists of 16 pairs of differential data signals plus two clock pairs into two separate buses A and B loading the left and right half of the SRAM array. The data is latched on both transitions creating a double data rate (DDR) interface. The subLVDS interface also implements a continuous training algorithm to optimize the data and clock timing to allow for a more robust interface.

The entire DMD array of 0.9 million pixels can be updated at a rate of less than 100 μ s as a result of the high speed subLVDS interface.

7.3.2 Low Speed Interface for Control

The purpose of the low speed interface is to configure the DMD at power up and power down and to control the micromirror reset voltage levels that are synchronized with the data loading. The micromirror reset voltage controls the time when the mirrors are mechanically switched. The low speed differential interface includes two pairs of signals for write data and clock, and two single-ended signals for output (A and B).

7.3.3 DMD Voltage Supplies

The micromirrors require unique voltage levels to control the mechanical switching from -12° to $+12^\circ$. These voltage levels are nominally 16 V, 8.5 V, and -10 V (VBIAS, VOFFSET, and VRESET), and are generated by the TPS99001-Q1.

7.3.4 Asynchronous Reset

Reset of the DMD is required and controlled by the DLPC230-Q1 via the signal DMD_DEN_ARSTZ.

7.3.5 Temperature Sensing Diode

The DMD includes a temperature sensing diode designed to be used with the TMP411 temperature monitoring device. The DLPC230-Q1 monitors the temperature sense diode via the TMP411. The DLPC230-Q1 operation of the DMD timing can be adjusted based on the DMD array temperature, therefore this connection is essential to ensure reliable operation of the DMD.

图 7-1 shows the typical connection between the DLPC230-Q1, TMP411, and the DMD.



图 7-1. Temperature Sense Diode Typical Circuit Configuration

7.3.5.1 Temperature Sense Diode Theory

A temperature sensing diode is based on the fundamental current and temperature characteristics of a transistor. The diode is formed by connecting the transistor base to the collector. Three different known currents flow through the diode and the resulting diode voltage is measured in each case. The difference in their base - emitter voltages is proportional to the absolute temperature of the transistor.

Refer to the TMP411-Q1 data sheet for detailed information about temperature diode theory and measurement. [图 7-2](#) and [图 7-3](#) illustrate the relationships between the current and voltage through the diode.

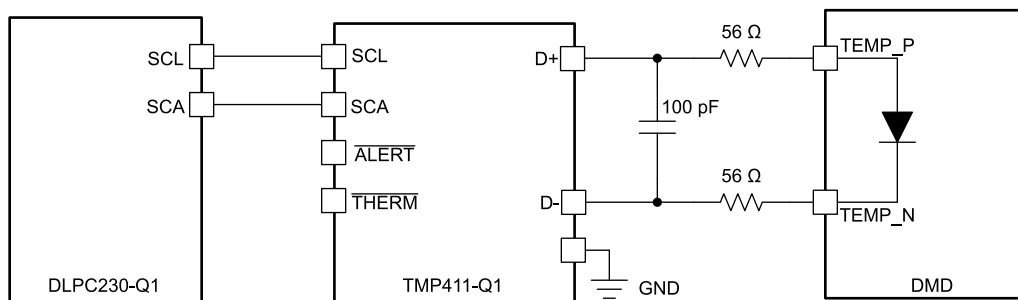

图 7-2. Temperature Measurement Theory



图 7-3. Example of Delta VBE Versus Temperature

7.4 System Optical Considerations

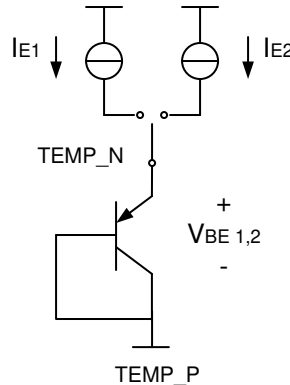
Optimizing system optical performance and image performance strongly relates to optical system design parameter trades. Although it is not possible to anticipate every conceivable application, projector image and optical performance is contingent on compliance to the optical system operating conditions described in the following sections.

7.4.1 Numerical Aperture and Stray Light Control

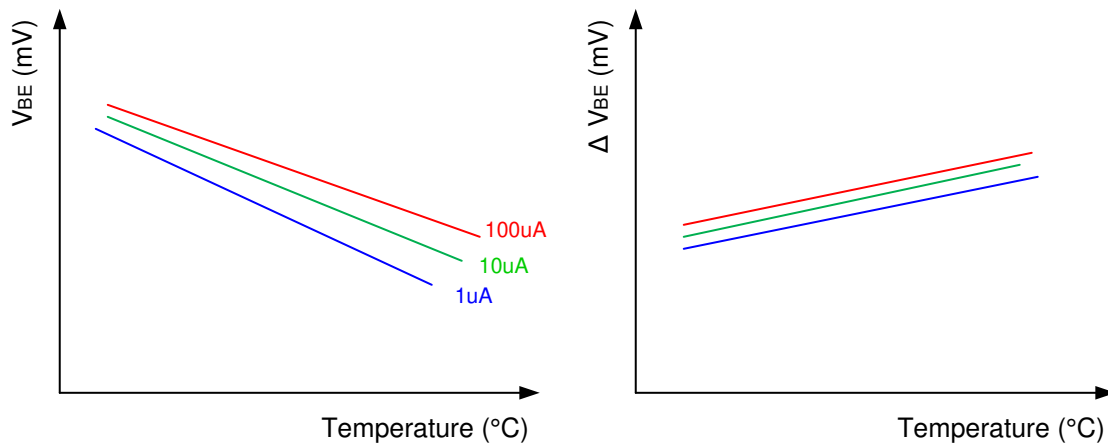
The numerical aperture of the illumination and projection optics at the DMD optical area should be the same. This cone angle defined by the numerical aperture should not exceed the nominal device mirror tilt angle unless appropriate apertures are added in the illumination and/or projection pupils to block out flat-state and stray light from the projection lens. The mirror tilt angle defines the DMD's capability to separate the "On" optical path from any other light path, including undesirable flat-state specular reflections from the DMD window, DMD border structures, or other system surfaces near the DMD such as prism or lens surfaces.

7.4.2 Pupil Match

TI's optical and image performance specifications assume that the exit pupil of the illumination optics is nominally centered and located at the entrance pupil position of the projection optics. Misalignment of pupils between the illumination and projection optics can degrade screen image uniformity and cause objectionable artifacts in the display's border and/or active area. These artifacts may require additional system apertures to control, especially if the numerical aperture of the system exceeds the pixel tilt angle.

7.4.3 Illumination Overfill

Overfill light illuminating the area outside the active array can create artifacts from the mechanical features and other surfaces that surround the active array. These artifacts may be visible in the projected image. The illumination optical system should be designed to minimize light flux incident outside the active array and on the window aperture. Depending on the particular system's optical architecture and assembly tolerances, this amount of overfill light on the area outside of the active array may still cause artifacts to be visible.

Illumination light and overfill can also induce undesirable thermal conditions on the DMD, especially if illumination light impinges directly on the DMD window aperture or near the edge of the DMD window. Heat load on the aperture in the areas shown in [图 6-1](#) should not exceed the values listed in [节 6.4](#). This area is a 0.5-mm wide area and length of the aperture opening. The values listed in [节 6.4](#) assume a uniform distribution. For a non-uniform distribution please contact TI for additional information.

备注

TI ASSUMES NO RESPONSIBILITY FOR IMAGE QUALITY ARTIFACTS OR DMD FAILURES CAUSED BY OPTICAL SYSTEM OPERATING CONDITIONS EXCEEDING LIMITS DESCRIBED PREVIOUSLY.

7.5 DMD Image Performance Specification

表 7-1. DMD Image Performance

PARAMETER ^{(1) (2)}	MIN	NOM	MAX	UNIT
Dark Blemishes—Viewed on a linear blue 60 screen ⁽³⁾			4	
Light Blemishes—Viewed on a linear gray 10 screen.			4	
Bright Pixels—Viewed on a linear gray 10 screen.			0	micromirrors
Dark Pixels—Viewed on a white screen			4	micromirrors

- (1) See the [System Optical Considerations](#) section.
- (2) Blemish counts do not include reflections or shadows of the same artifact. Any artifact that is not specifically called out in this table is acceptable. Viewing distance must be > 60 in. Screen size should be similar to application image size. All values referenced are in linear gamma. Non-linear gamma curves may be running by default, and it should be ensured with a TI applications engineer that the equivalent linear gamma value as specified is used to judge artifacts.
- (3) Linear gray 5 may be substituted in monochrome applications.

7.6 Micromirror Array Temperature Calculation



图 7-4. DMD Thermal Test Points

The active array temperature can be computed analytically from the thermal measurement point on the outside of the package, the package thermal resistance, the electrical power, and the illumination heat load. The relationship between the array temperature and the reference ceramic temperature (TP1) in Figure 7-4 is provided by the following equations:

$$T_{\text{ARRAY}} = T_{\text{CERAMIC}} + (Q_{\text{ARRAY}} \times R_{\text{ARRAY - TO - CERAMIC}}) \quad (1)$$

$$Q_{\text{ILLUMINATION}} = (Q_{\text{INCIDENT}} \times \text{DMD Absorption Constant}) \quad (2)$$

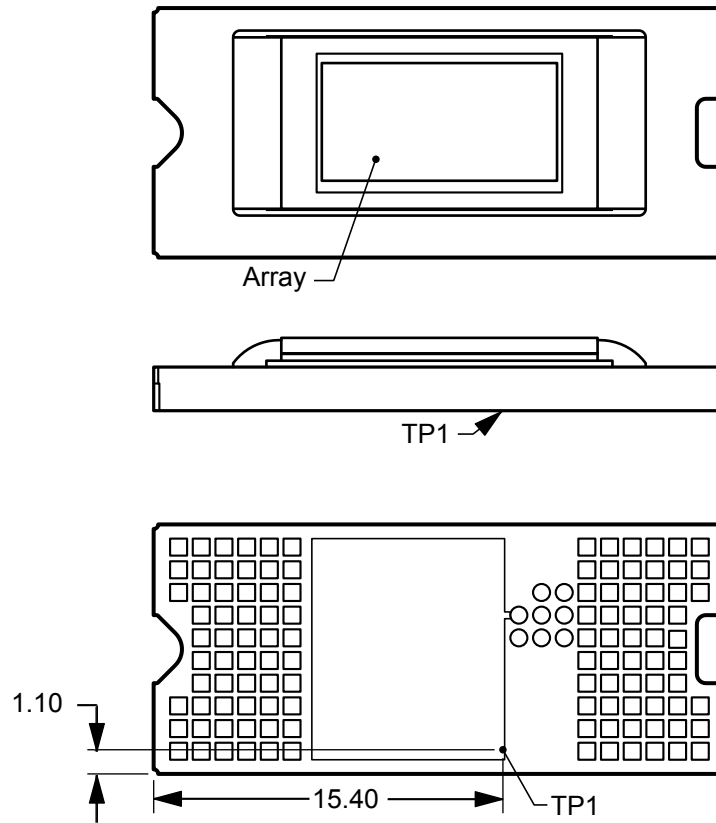
$$Q_{\text{ARRAY}} = Q_{\text{ELECTRICAL}} + Q_{\text{ILLUMINATION}} \quad (3)$$

where

- T_{ARRAY} = computed array temperature (°C)
- T_{CERAMIC} = measured ceramic temperature at the TP1 location in [DMD Thermal Test Points](#) (°C)
- $R_{\text{ARRAY - TO - CERAMIC}}$ = DMD package thermal resistance from array to thermal test point TP1 (°C/W),
- Q_{ARRAY} = total power (electrical plus absorbed) on the DMD array (W)
- $Q_{\text{ELECTRICAL}}$ = nominal electrical power dissipation by the DMD (W)
- $Q_{\text{ILLUMINATION}}$ = absorbed illumination heat load (W)
- Q_{INCIDENT} = incident power on the DMD (W)

The DMD absorption constant is a function of illumination distribution on the active array and the array border, angle of incidence (AOI), f number of the system, and operating state of the mirrors. The absorption constant is higher in the OFF state than in the ON state. Equations to calculate the absorption constant are provided for

both ON and OFF mirror states. They assume an AOI of 34 degrees, an f/1.7 system, and they account for the distribution of light on the active array, POM, and array border.

$$\text{DMD Absorption Constant (OFF state)} = 0.895 - 0.004783 \times (\% \text{ of light on ActiveArray} + \text{POM}) \quad (4)$$

$$\text{DMD Absorption Constant (ON state)} = 0.895 - 0.007208 \times (\% \text{ of light on ActiveArray} + \text{POM}) \quad (5)$$

Electrical power dissipation of the DMD is variable and depends on the voltages, data rates, and operating frequencies.

The DMD package thermal resistance from array to ceramic ($R_{\text{ARRAY} - \text{TO} - \text{CERAMIC}}$) assumes a non-uniform illumination distribution on the DMD as shown in [Non-Uniform Illumination Profile](#). For illumination profiles more uniform than the one highlighted in [Non-Uniform Illumination Profile](#), the value provided here is valid. However, for more non-uniform profiles (for example, Gaussian distribution) the thermal resistance will be higher. Please contact TI to determine an accurate value for this case.



图 7-5. Non-Uniform Illumination Profile

The following sample calculations assume 10% of the total incident light falls outside of the active array and POM, and the mirrors are in the OFF state.

1. $T_{\text{CERAMIC}} = 50^{\circ}\text{C}$ (measured)
2. $Q_{\text{INCIDENT}} = 10 \text{ W}$ (measured)
3. $\text{DMD Absorption Constant} = 0.895 - 0.004783 \times 90 = 0.46$
4. $Q_{\text{ELECTRICAL}} = 0.4 \text{ W}$

5. $R_{\text{ARRAY-TO-CERAMIC}} = 1.5^{\circ}\text{C/W}$
6. $Q_{\text{ARRAY}} = 0.4\text{ W} + (0.46 \times 10\text{ W}) = 5\text{ W}$
7. $T_{\text{ARRAY}} = 50^{\circ}\text{C} \times (5\text{ W} \times 1.5^{\circ}\text{C/W}) = 57.5^{\circ}\text{C}$

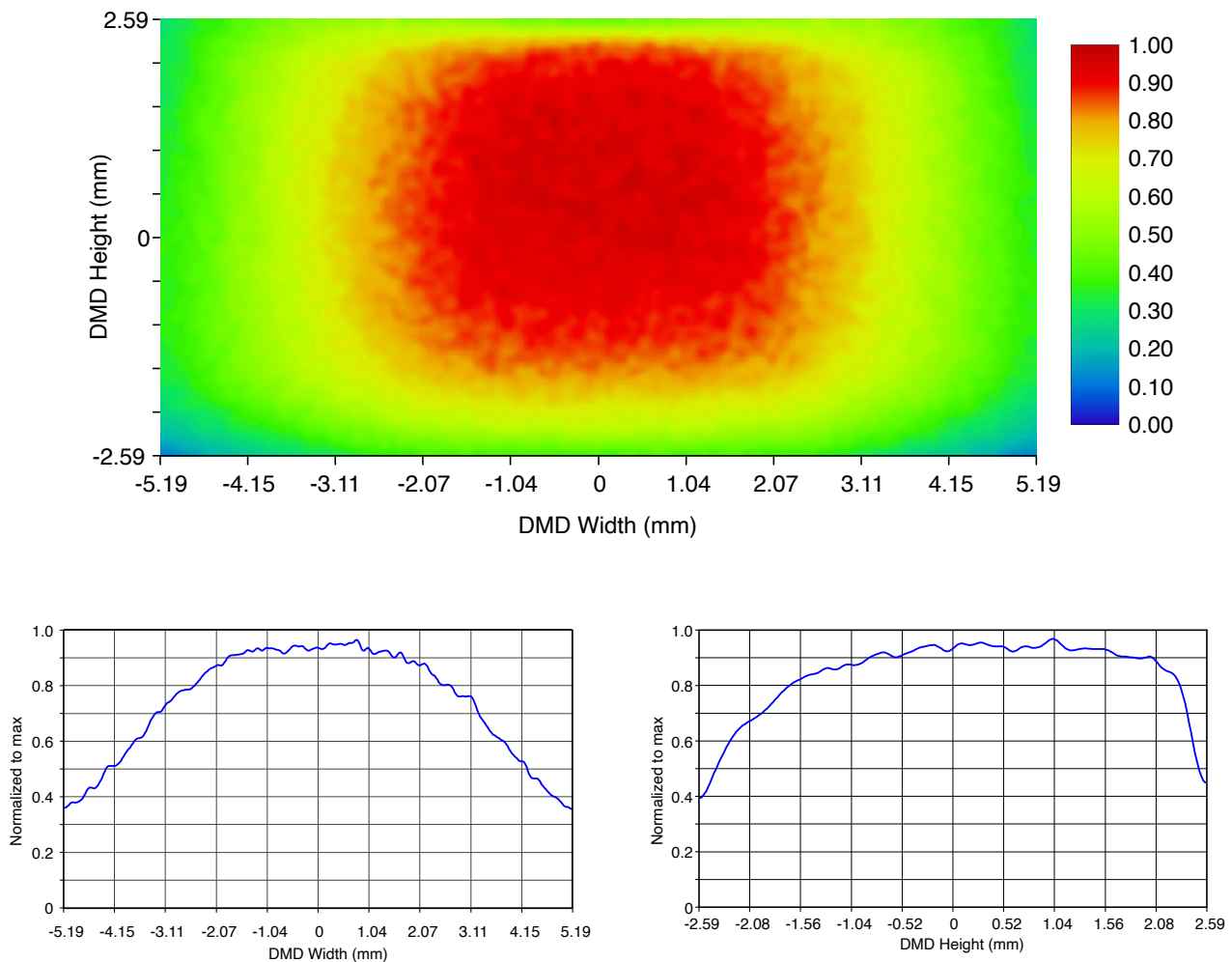
When designing the DMD heatsink solution, the package thermal resistance from array to reference ceramic temperature (thermocouple location TP1 can be used to determine the temperature rise through the package as given by the following equations:

$$T_{\text{ARRAY-TO-CERAMIC}} = Q_{\text{ARRAY}} \times R_{\text{ARRAY-TO-CERAMIC}} \quad (6)$$

7.6.1 Monitoring Array Temperature Using the Temperature Sense Diode

The active array temperature can be computed analytically from the temperature sense diode measurement, the thermal resistance from array to diode, the electrical power, and the illumination heat load. The relationship between array temperature and the temperature sense diode is provided by the following equations:

$$T_{\text{ARRAY}} = T_{\text{DIODE}} + (Q_{\text{ARRAY}} \times R_{\text{ARRAY-TO-DIODE}}) \quad (7)$$

$$Q_{\text{ILLUMINATION}} = (Q_{\text{INCIDENT}} \times \text{DMD Absorption Constant}) \quad (8)$$

$$Q_{\text{ARRAY}} = Q_{\text{ELECTRICAL}} + Q_{\text{ILLUMINATION}} \quad (9)$$

where

- T_{ARRAY} = computed array temperature ($^{\circ}\text{C}$)
- T_{DIODE} = measured temperature sense diode temperature ($^{\circ}\text{C}$)
- $R_{\text{ARRAY-TO-DIODE}}$ = package thermal resistance from array to diode ($^{\circ}\text{C/W}$)
- Q_{ARRAY} = total power, electrical plus absorbed, on the DMD array (W)
Refer to [Section 7.6](#) for details.
- $Q_{\text{ELECTRICAL}}$ = nominal electrical power dissipation by the DMD (W)
- $Q_{\text{ILLUMINATION}}$ = absorbed illumination heat load (W)
- Q_{INCIDENT} = incident power on the DMD (W)

The temperature sense diode to array thermal resistance ($R_{\text{ARRAY-TO-DIODE}}$) assumes a non-uniform illumination distribution on the DMD as shown in *Non-Uniform Illumination Profile*. For illumination profiles more uniform than the one highlighted in *Non-Uniform Illumination Profile*, the value provided here is valid. However, for more non-uniform profiles (for example, Gaussian distribution), the thermal resistance will be higher. Please contact TI to determine an accurate value for this case.

The following sample calculations assume 10% of the total incident light falls outside of the active array and POM, and the mirrors are in the OFF state.

1. $T_{\text{DIODE}} = 45^{\circ}\text{C/W}$
2. $Q_{\text{INCIDENT}} = 10\text{ W}$ (measured)
3. $\text{DMD Absorption Constant} = 0.895 - 0.004783 \times 90 = 0.46$
4. $Q_{\text{ELECTRICAL}} = 0.4\text{ W}$
5. $R_{\text{ARRAY-TO-DIODE}} = 0.5^{\circ}\text{C/W}$
6. $Q_{\text{ARRAY}} = 0.4\text{ W} + (0.46 \times 10\text{ W}) = 5\text{ W}$
7. $T_{\text{ARRAY}} = 54^{\circ}\text{C} + (5\text{ W} \times 0.5^{\circ}\text{C/W}) = 56.5^{\circ}\text{C}$

7.7 Micromirror Landed-On/Landed-Off Duty Cycle

7.7.1 Definition of Micromirror Landed-On/Landed-Off Duty Cycle

The micromirror landed-on/landed-off duty cycle (landed duty cycle) denotes the amount of time (as a percentage) that an individual micromirror is landed in the ON state versus the amount of time the same micromirror is landed in the OFF state.

As an example, a landed duty cycle of 90/10 indicates that the referenced pixel is in the ON state 90% of the time (and in the OFF state 10% of the time), whereas 10/90 would indicate that the pixel is in the OFF state 90% of the time. Likewise, 50/50 indicates that the pixel is ON 50% of the time and OFF 50% of the time.

Note that when assessing landed duty cycle, the time spent switching from one state (ON or OFF) to the other state (OFF or ON) is considered negligible and is thus ignored.

Since a micromirror can only be landed in one state or the other (ON or OFF), the two numbers (percentages) always add to 100.

8 Application and Implementation

备注

Information in the following applications sections is not part of the TI component specification, and TI does not warrant its accuracy or completeness. TI's customers are responsible for determining suitability of components for their purposes, as well as validating and testing their design implementation to confirm system functionality.

8.1 Application Information

The DLP4621-Q1 chipset is designed to support projection-based automotive applications such as high resolution adaptive driving beam (ADB) headlights.

8.2 Typical Application

The chipset consists of three components—the DLP4621-Q1 automotive DMD, the DLPC230-Q1, and the TPS99001-Q1. The DMD is a light modulator consisting of tiny mirrors that are used to form and project images. The DLPC230-Q1 is a controller for the DMD; it formats incoming video and controls the timing of the DMD illumination sources and the DMD in order to display the incoming video. The TPS99001-Q1 is a high performance voltage regulator for the DMD and a management IC for the entire chipset. In conjunction, the DLPC230-Q1 and the TPS99001-Q1 can be used for system-level monitoring, diagnostics, and failure detection features. [图 8-1](#) is a system level block diagram with these devices in the DLP headlight module configuration and displays the primary features and functions of each device.



图 8-1. Headlight System Block Diagram

ADVANCE INFORMATION

8.2.1 Application Overview

图 8-1 shows the system block diagram for a DLP headlight module. The system uses the DLPC230-Q1, TPS99001-Q1, and the DLP4621-Q1 automotive DMD to enable a headlight projection system with unprecedented resolution and grayscale light control. The combination of the DLPC230-Q1 and TPS99001-Q1 removes the need for external SDRAM and a dedicated microprocessor. The chipset manages the illumination control of LED sources, power sequencing functions, and system management functions. Additionally, the chipset supports numerous system diagnostic and built-in self test (BIST) features. The following paragraphs describe the functionality of the chipset used for a headlight projection system in more detail.

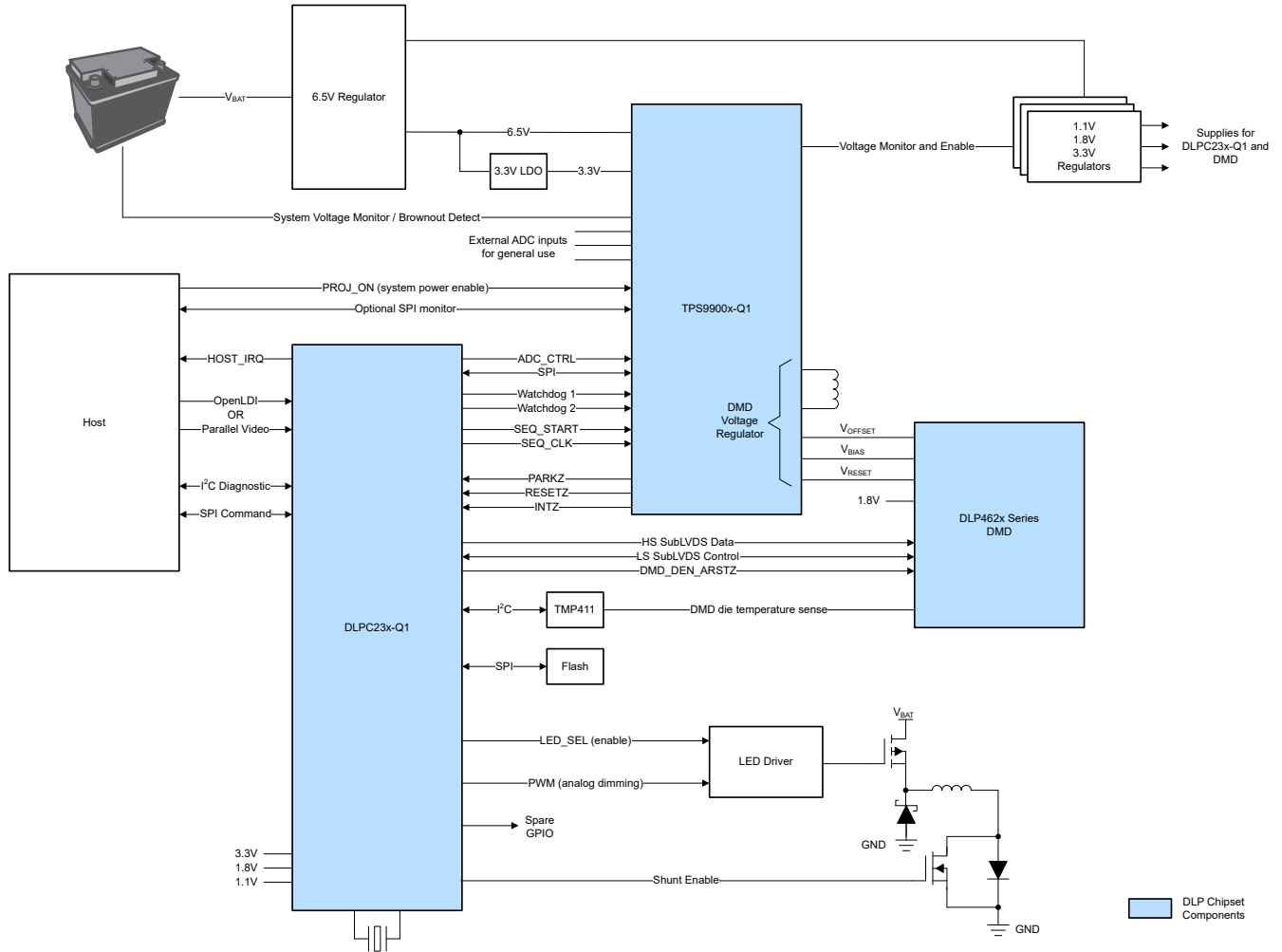
The DLPC230-Q1 is a controller for the DMD and the light sources in the DLP Headlight, HUD or Projector module. It receives input video from the host and synchronizes DMD and light source timing in order to achieve the desired video. The DLPC230-Q1 formats input video data that is displayed on the DMD. It synchronizes these video segments with light source timing in order to create a video with grayscale shading and multiple colors, if applicable.

The DLPC230-Q1 receives inputs from a host processor in the vehicle. The host provides commands and input video data. Host commands can be sent using either the I²C bus or SPI bus. The bus that is not being used for host commands can be used as a read-only bus for diagnostic purposes. Input video can be sent over an OpenLDI bus or a parallel 24-bit bus. The 24-bit bus can be limited to only 8-bits or 16-bits of data for single light source or dual light source systems depending on the system design. The SPI flash memory provides the embedded software for the DLPC230-Q1's ARM core, any calibration data, and default settings. The TPS99001-Q1 provides diagnostic and monitoring information to the DLPC230-Q1 using an SPI bus and several other control signals such as PARKZ, INTZ, and RESETZ to manage power-up and power-down sequencing. The TMP411 uses an I²C interface to provide the DMD array temperature to the DLPC230-Q1.

The outputs of the DLPC230-Q1 are configuration and monitoring commands to the TPS99001-Q1, timing controls to the LED or laser driver, control and data signals to the DMD, and monitoring and diagnostics information to the host processor. The DLPC230-Q1 communicates with the TPS99001-Q1 over an SPI bus. It uses this to configure the TPS99001-Q1 and to read monitoring and diagnostics information from the TPS99001-Q1. The DLPC230-Q1 sends drive enable signals to the LED or laser driver, and synchronizes this with the DMD mirror timing. The control signals to the DMD are sent using a subLVDS interface.

The TPS99001-Q1 is a highly integrated mixed-signal IC that controls DMD power and provides monitoring and diagnostics information for the DLP headlight module. The power sequencing and monitoring blocks of the TPS99001-Q1 properly power up the DMD and provide accurate DMD voltage rails (- 16 V, 8.5 V, and 10 V), and then monitor the system's power rails during operation. The integration of these functions into one IC significantly reduces design time and complexity. The TPS99001-Q1 also has several output signals that can be used to control a variety of LED or laser driver topologies. The TPS99001-Q1 has several general-purpose ADCs that designers can use for system level monitoring, such as over-brightness detection.

The TPS99001-Q1 receives inputs from the DLPC230-Q1, the power rails it monitors, the host processor, and potentially several other ADC ports. The DLPC230-Q1 sends configuration and control commands to the TPS99001-Q1 over an SPI bus and several other control signals. The DLPC230-Q1's clocks are also monitored by the watchdogs in the TPS99001-Q1 to detect any errors. The power rails are monitored by the TPS99001-Q1 in order to detect power failures or glitches and request a proper power down of the DMD in case of an error. The host processor can read diagnostics information from the TPS99001-Q1 using a dedicated SPI bus, which enables independent monitoring. Additionally, the host can request the image to be turned on or off using a PROJ_ON signal. Lastly, the TPS99001-Q1 has several general-purpose ADCs that can be used to implement system level monitoring functions.

The outputs of the TPS99001-Q1 are diagnostic information and error alerts to the DLPC230-Q1, and control signals to the LED or laser driver. The TPS99001-Q1 can output diagnostic information to the host and the DLPC230-Q1 over two SPI buses. In case of critical system errors, such as power loss, it outputs signals to the DLPC230-Q1 that trigger power down or reset sequences. It also has output signals that can be used to implement various LED or laser driver topologies.

The DMD is a micro-electro-mechanical system (MEMS) device that receives electrical signals as an input (video data), and produces a mechanical output (mirror position). The electrical interface to the DMD is a subLVDS interface with the DLPC230-Q1. The mechanical output is the state of more than 0.9 million mirrors in the DMD array that can be tilted $\pm 12^\circ$. In a projection system the mirrors are used as pixels in order to display an image.

8.2.2 Reference Design

For information about connecting together the DLP4621-Q1 DMD, DLPC230-Q1 controller, and TPS99001-Q1, please contact the TI Application Team for additional information about the DLP4621-Q1 evaluation module (EVM). TI has optical-mechanical reference designs available, see the TI Application team for more information.

8.2.3 Application Mission Profile Consideration

Each application is anticipated to have different mission profiles, or number of operating hours at different temperatures. To assist in evaluation an Application Report may be provided in the future. See the TI Application team for more information.

9 Power Supply Recommendations

The following power supplies are all required to operate the DMD: VDD, VDDI, VOFFSET, VBIAS, and VRESET. All VSS connections are also required. DMD power-up and power-down sequencing is strictly controlled by the TPS99001-Q1 device.

CAUTION

For reliable operation of the DMD, the following power supply sequencing requirements must be followed. Failure to adhere to the prescribed power-up and power-down procedures may affect device reliability.

VDD, VDDI, VOFFSET, VBIAS, and VRESET power supplies have to be coordinated during power-up and power-down operations. Failure to meet any of the below requirements will result in a significant reduction in the DMD's reliability and lifetime. VSS must also be connected.

9.1 Power Supply Power-Up Procedure

- During power-up, VDD and VDDI must always start and settle before VOFFSET, VBIAS, and VRESET voltages are applied to the DMD.
- During power-up, it is a strict requirement that the delta between VBIAS and VOFFSET must be within the specified limit shown in the *Recommended Operating Conditions*.
- During power-up, the DMD's LPSDR input pins shall not be driven high until after VDD and VDDI have settled at operating voltage.
- During power-up, there is no requirement for the relative timing of VRESET with respect to VOFFSET and VBIAS. Power supply slew rates during power-up are flexible, provided that the transient voltage levels follow the requirements listed previously and in [图 9-1](#).

9.2 Power Supply Power-Down Procedure

- The power-down sequence is the reverse order of the previous power-up sequence. VDD and VDDI must be supplied until after VBIAS, VRESET, and VOFFSET are discharged to within 4 V of ground.
- During power-down, it is not mandatory to stop driving VBIAS prior to VOFFSET, but it is a strict requirement that the delta between VBIAS and VOFFSET must be within the specified limit shown in the *Recommended Operating Conditions* (refer to Note 2 in [节 9.3](#)).
- During power-down, the DMD's LPSDR input pins must be less than VDDI, the specified limit shown in the *Recommended Operating Conditions*.
- During power-down, there is no requirement for the relative timing of VRESET with respect to VOFFSET and VBIAS.
- Power supply slew rates during power-down are flexible, provided that the transient voltage levels follow the requirements listed previously and in [节 9.3](#).

9.3 Power Supply Sequencing Requirements

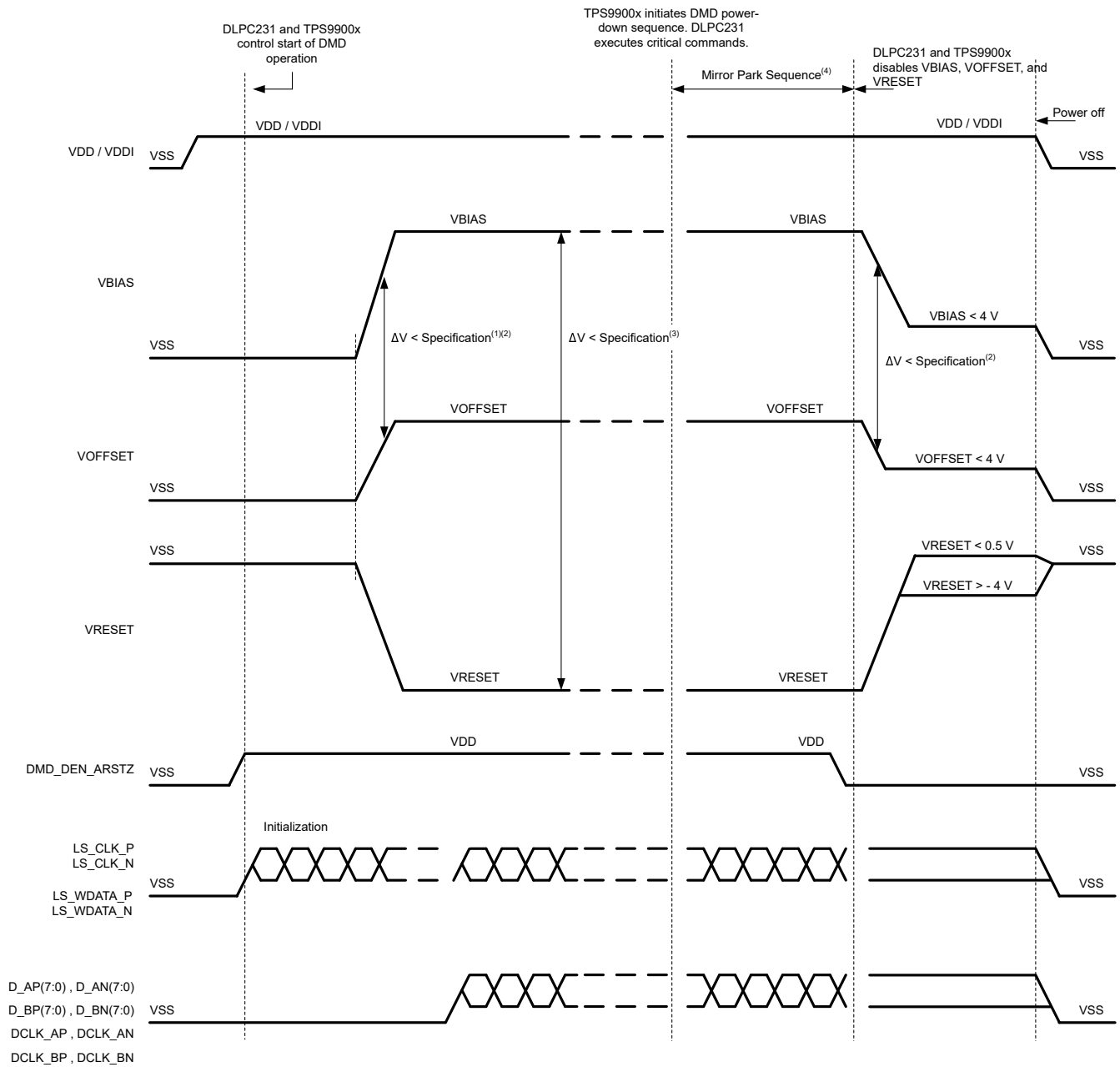

ADVANCE INFORMATION

- To prevent excess current, the supply voltage delta $|VBIAS - VOFFSET|$ must be less than specified in the [Recommended Operating Conditions](#). OEMs may find that the most reliable way to ensure this is to power VOFFSET prior to VBIAS during power-up and to remove VBIAS prior to VOFFSET during power-down. Also, the TPS99001-Q1 is capable of managing the timing between VBIAS and VOFFSET.
- To prevent excess current, the supply voltage delta $|VBIAS - VRESET|$ must be less than specified than the limit shown in the [Recommended Operating Conditions](#).
- When system power is interrupted, the TPS99001-Q1 initiates hardware power-down that disables VBIAS, VRESET, and VOFFSET after the Micromirror Park Sequence.
- The drawing is not to scale and details are omitted for clarity.

图 9-1. Power Supply Sequencing Requirements (Power Up and Power Down)

10 Layout

10.1 Layout Guidelines

Please refer to the DLPC230-Q1 and TPS99001-Q1 data sheets for specific PCB layout and routing guidelines. For specific DMD PCB guidelines, use the following:

- Match lengths for the LS_WDATA and LS_CLK signals
- Minimize vias, layer changes, and turns for the HS bus signals
- Minimum of two 220-nF decoupling capacitors close to VBIAS
- Minimum of two 220-nF decoupling capacitors close to VRESET
- Minimum of two 220-nF decoupling capacitors close to VOFFSET
- Minimum of four 100-nF decoupling capacitors close to VDDI and VDD
- Temperature diode pins

The DMD has an internal diode (PN junction) that is intended to be used with an external TI TMP411 temperature sensing IC. PCB traces from the DMD's temperature diode pins to the TMP411 are sensitive to noise. See the [TMP411 \$\pm 1^\circ\text{C}\$ Remote and Local Temperature Sensor with N-Factor and Series Resistance Correction Data Sheet](#) for specific routing recommendations.

11 Device and Documentation Support

11.1 第三方产品免责声明

TI 发布的与第三方产品或服务有关的信息，不能构成与此类产品或服务或保修的适用性有关的认可，不能构成此类产品或服务单独或与任何 TI 产品或服务一起的表示或认可。

11.2 Device Support

11.2.1 Device Nomenclature



图 11-1. Part Number Description

11.2.2 Device Markings

The device marking includes the legible character string GHJJJK DLP4621AFQXQ1. GHJJJK is the lot trace code. DLP4621AFQXQ1 is the part number.

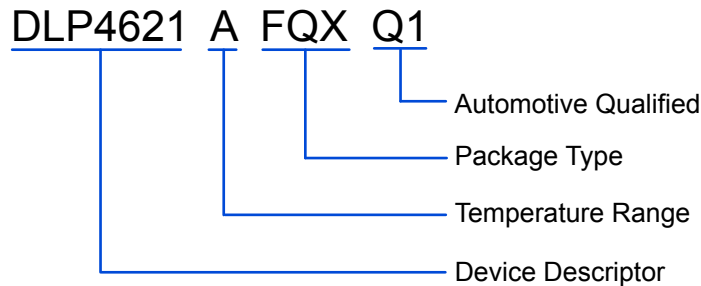

图 11-2. DMD Marking

11.3 Trademarks

DLP® is a registered trademark of Texas Instruments.

所有商标均为其各自所有者的财产。

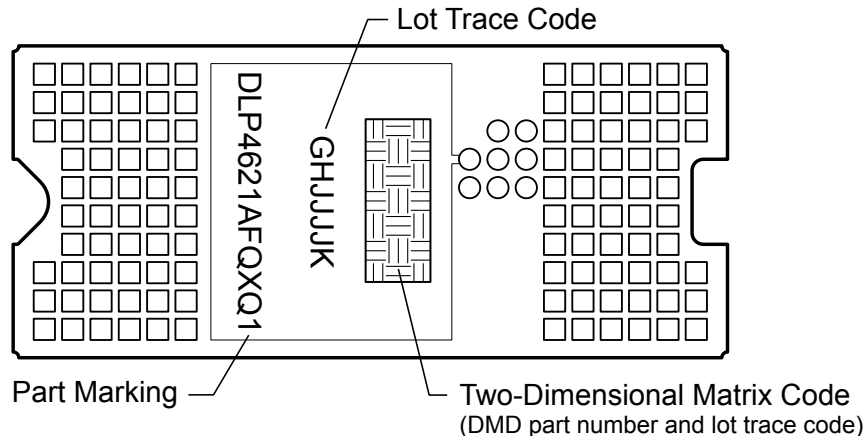
11.4 静电放电警告



静电放电 (ESD) 会损坏这个集成电路。德州仪器 (TI) 建议通过适当的预防措施处理所有集成电路。如果不遵守正确的处理和安装程序，可能会损坏集成电路。

ESD 的损坏小至导致微小的性能降级，大至整个器件故障。精密的集成电路可能更容易受到损坏，这是因为非常细微的参数更改都可能会导致器件与其发布的规格不相符。

11.5 DMD Handling

The DMD is an optical device so precautions should be taken to avoid damaging the glass window. Please see the application note [DLPA019 DMD Handling](#) for instructions on how to properly handle the DMD.

11.6 术语表

[TI 术语表](#) 本术语表列出并解释了术语、首字母缩略词和定义。

12 Mechanical, Packaging, and Orderable Information

The following pages include mechanical, packaging, and orderable information. This information is the most current data available for the designated devices. This data is subject to change without notice and revision of this document. For browser-based versions of this data sheet, refer to the left-hand navigation.

PACKAGING INFORMATION

Orderable Device	Status (1)	Package Type	Package Drawing	Pins	Package Qty	Eco Plan (2)	Lead finish/ Ball material (6)	MSL Peak Temp (3)	Op Temp (°C)	Device Marking (4/5)	Samples
XDLP4621AFQXQ1	ACTIVE	CLGA	FQX	120	72	RoHS & Green	Call TI	N / A for Pkg Type	-40 to 105		Samples

(1) The marketing status values are defined as follows:

ACTIVE: Product device recommended for new designs.

LIFEBUY: TI has announced that the device will be discontinued, and a lifetime-buy period is in effect.

NRND: Not recommended for new designs. Device is in production to support existing customers, but TI does not recommend using this part in a new design.

PREVIEW: Device has been announced but is not in production. Samples may or may not be available.

OBSELETE: TI has discontinued the production of the device.

(2) **RoHS:** TI defines "RoHS" to mean semiconductor products that are compliant with the current EU RoHS requirements for all 10 RoHS substances, including the requirement that RoHS substance do not exceed 0.1% by weight in homogeneous materials. Where designed to be soldered at high temperatures, "RoHS" products are suitable for use in specified lead-free processes. TI may reference these types of products as "Pb-Free".

RoHS Exempt: TI defines "RoHS Exempt" to mean products that contain lead but are compliant with EU RoHS pursuant to a specific EU RoHS exemption.

Green: TI defines "Green" to mean the content of Chlorine (Cl) and Bromine (Br) based flame retardants meet JS709B low halogen requirements of <=1000ppm threshold. Antimony trioxide based flame retardants must also meet the <=1000ppm threshold requirement.

(3) MSL, Peak Temp. - The Moisture Sensitivity Level rating according to the JEDEC industry standard classifications, and peak solder temperature.

(4) There may be additional marking, which relates to the logo, the lot trace code information, or the environmental category on the device.

(5) Multiple Device Markings will be inside parentheses. Only one Device Marking contained in parentheses and separated by a "-" will appear on a device. If a line is indented then it is a continuation of the previous line and the two combined represent the entire Device Marking for that device.

(6) Lead finish/Ball material - Orderable Devices may have multiple material finish options. Finish options are separated by a vertical ruled line. Lead finish/Ball material values may wrap to two lines if the finish value exceeds the maximum column width.

Important Information and Disclaimer:The information provided on this page represents TI's knowledge and belief as of the date that it is provided. TI bases its knowledge and belief on information provided by third parties, and makes no representation or warranty as to the accuracy of such information. Efforts are underway to better integrate information from third parties. TI has taken and continues to take reasonable steps to provide representative and accurate information but may not have conducted destructive testing or chemical analysis on incoming materials and chemicals. TI and TI suppliers consider certain information to be proprietary, and thus CAS numbers and other limited information may not be available for release.

In no event shall TI's liability arising out of such information exceed the total purchase price of the TI part(s) at issue in this document sold by TI to Customer on an annual basis.

TRAY

Chamfer on Tray corner indicates Pin 1 orientation of packed units.

*All dimensions are nominal

Device	Package Name	Package Type	Pins	SPQ	Unit array matrix	Max temperature (°C)	L (mm)	W (mm)	K0 (µm)	P1 (mm)	CL (mm)	CW (mm)
XDLP4621AFQXQ1	FQX	CLGA	120	72	8 x 7	150	315	135.9	12190	21.9	15.15	16.95

重要声明和免责声明

TI“按原样”提供技术和可靠性数据（包括数据表）、设计资源（包括参考设计）、应用或其他设计建议、网络工具、安全信息和其他资源，不保证没有瑕疵且不做任何明示或暗示的担保，包括但不限于对适销性、某特定用途方面的适用性或不侵犯任何第三方知识产权的暗示担保。

这些资源可供使用 TI 产品进行设计的熟练开发人员使用。您将自行承担以下全部责任：(1) 针对您的应用选择合适的 TI 产品，(2) 设计、验证并测试您的应用，(3) 确保您的应用满足相应标准以及任何其他功能安全、信息安全、监管或其他要求。

这些资源如有变更，恕不另行通知。TI 授权您仅可将这些资源用于研发本资源所述的 TI 产品的应用。严禁对这些资源进行其他复制或展示。您无权使用任何其他 TI 知识产权或任何第三方知识产权。您应全额赔偿因在这些资源的使用中对 TI 及其代表造成的任何索赔、损害、成本、损失和债务，TI 对此概不负责。

TI 提供的产品受 [TI 的销售条款](#) 或 [ti.com](#) 上其他适用条款/TI 产品随附的其他适用条款的约束。TI 提供这些资源并不会扩展或以其他方式更改 TI 针对 TI 产品发布的适用的担保或担保免责声明。

TI 反对并拒绝您可能提出的任何其他或不同的条款。

邮寄地址：Texas Instruments, Post Office Box 655303, Dallas, Texas 75265

Copyright © 2023，德州仪器 (TI) 公司