

OPT4048 高速高精度三色 XYZ 颜色传感器

1 特性

- 通过高速 I2C 接口实现高精度、高速颜色光/数转换
- 使用精密光学滤波器的四通道感应：
 - XYZ 三色通道与 CIE 1931 光谱密切匹配，具有出色的红外抑制功能
 - 清晰的宽带宽通道
- CIE XY 中的高分辨率颜色测量、LUV 空间、相关色温 (CCT) 以及环境照度测量
- 半对数输出，具有 7 个二进制对数满标度照度范围，在每个范围内具有高度线性响应
- 内置自动满标度照度范围选择逻辑，可根据输入光条件切换测量范围，范围之间具有良好的增益匹配
- 26 位有效动态范围，从 2.15mlux 到 144klux
- 12 个可配置转换时间，每个通道为 600 μ s 到 800ms，适用于各种高速和高精度应用
- 针对硬件同步触发和中断的外部引脚中断
- 低工作电流：24 μ A，具有超低待机功耗：2 μ A
- 工作温度范围：-40°C 至 +85°C
- 宽电源范围：1.6V 至 3.6V
- 耐受 5.5V 电压的 I/O
- 可选择的 I2C 地址
- 小巧的外形：
 - 2.1mm x 1.9mm x 0.6mm SOT-5X3 封装

2 应用

- 显示亮度和颜色调整
- 摄像头图像校正

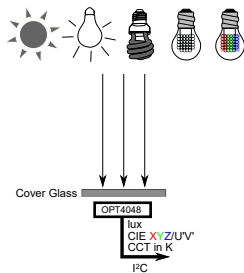

- 自动白平衡
- 楼宇自动化与控制
- 照明控制系统
- 平板电脑和笔记本电脑

3 说明

OPT4048 是一款单芯片高分辨率颜色传感器，能够测量四个通道，每个通道具有特定设计的光谱响应。四个通道中的三个通道与 CIE 三色光谱非常匹配，第四个通道具有宽带光谱响应。通过从这些通道进行测量，可以提取照明环境的重要特性，例如 (i) 光强度 (lux)、(ii) CIE XY 中的颜色、LUV 坐标以及 (iii) 相关色温。OPT4048 采用小型 SOT-5X3 封装。

OPT4048 具有可选寻址方案，可在共享的 I2C 总线上启用多达 4 个器件。这些通道的光谱响应经过专门调节，可紧密模拟 CIE 三色光谱，从而实现超精确的颜色检测，同时强烈抑制远离其各自峰值的波长，尤其是 NIR (850nm 和 940nm) 区域。这些滤波器采用先进的滤波技术，即使在更高的光入射角下也能提供出色的滤波性能。该器件具有高精度颜色检测功能，支持多种需要精确检测环境光颜色和色温的应用。

器件信息

器件型号	封装 ⁽¹⁾	封装尺寸 (标称值)
OPT4048	SOT-5X3 (8)	2.10mm X 1.90mm X 0.6mm

(1) 要了解所有可用封装，请参见数据表末尾的封装选项附录。

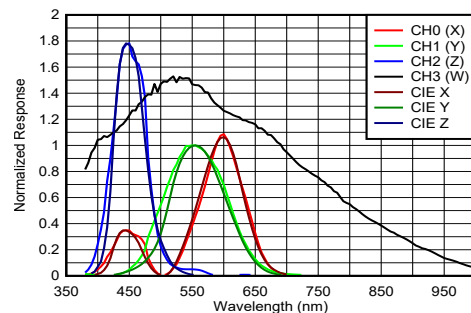

归一化光谱响应



Table of Contents

1 特性	1	8.4 Register Maps.....	24
2 应用	1	9 Application and Implementation	33
3 说明	1	9.1 Application Information.....	33
4 Revision History	2	9.2 Typical Application.....	33
5 说明 (续)	3	9.3 Do's and Don'ts.....	36
6 Pin Configuration and Functions	3	9.4 Power Supply Recommendations.....	37
7 Specifications	4	9.5 Layout.....	37
7.1 Absolute Maximum Ratings.....	4	10 Device and Documentation Support	39
7.2 ESD Ratings.....	4	10.1 Documentation Support.....	39
7.3 Recommended Operating Conditions.....	4	10.2 接收文档更新通知.....	39
7.4 Thermal Information.....	4	10.3 支持资源.....	39
7.5 Electrical Characteristics.....	5	10.4 Trademarks.....	39
7.6 Typical Characteristics.....	7	10.5 Electrostatic Discharge Caution.....	39
8 Detailed Description	9	10.6 术语表.....	39
8.1 Overview.....	9	11 Mechanical, Packaging, and Orderable	
8.2 Functional Block Diagram.....	10	Information	39
8.3 Feature Description.....	10		

4 Revision History

注：以前版本的页码可能与当前版本的页码不同

DATE	REVISION	NOTES
December 2022	*	Initial release.

5 说明 (续)

OPT4048 上设计的光学滤波器提供了强大的红外抑制功能，尽管传感器放置在深色玻璃下（这是最终产品工业设计出于美学考虑的常见要求），但这一功能也有助于保持高精度。

OPT4048 专为需要照度级别检测的系统而设计，通过提供有关照明强度和照明颜色的信息来增强用户体验。

OPT4048 器件可通过每个通道 12 个步骤配置为以 600 μ s 到 800ms 的光转换时间运行，从而能够根据应用需要提供系统灵活性。转换时间包括光采集时间和 ADC 转换时间。测量分辨率由光强度和采集时间两者决定，能够有效地测量低至 2.15mlux 的光强度变化。

数字操作可灵活用于系统集成。测量可以是连续的，也可以通过寄存器写入或硬件引脚单次触发。此器件提供了阈值检测逻辑，这允许处理器进入睡眠状态，直到传感器检测到适当的唤醒事件并通过中断引脚进行报告。

数字输出，表示通过兼容 I²C 和 SMBus 的双线制串行接口报告照度级别。

OPT4048 兼具低功耗和低电源电压功能，有助于延长电池供电系统的电池寿命。

6 Pin Configuration and Functions



图 6-1. DTS Package, 8-Pin SOT-5X3, Top View

表 6-1. Pin Functions

PIN		TYPE	DESCRIPTION
NO.	NAME		
1	VDD	Power	Device power. Connect to a 1.6-V to 3.6-V supply.
2	ADDR	Digital input	Address pin. This pin sets the LSBs of the I ² C address.
3	NC	No Connection	No Connection
4	GND	Power	Ground
5	SCL	Digital input	I ² C clock. Connect with a 10-k Ω resistor to a 1.6-V to 5.5-V supply.
6	NC	No Connection	No Connection
7	INT	Digital I/O	Interrupt input/output open-drain. Connect with a 10-k Ω resistor to a 1.6-V to 5.5-V supply.
8	SDA	Digital I/O	I ² C data. Connect with a 10-k Ω resistor to a 1.6-V to 5.5-V supply.

7 Specifications

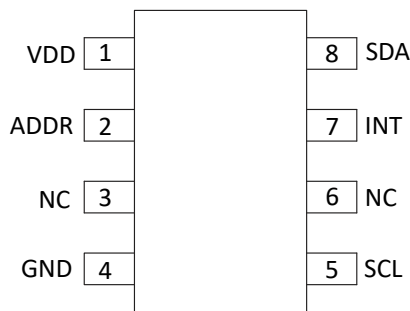
7.1 Absolute Maximum Ratings

over operating free-air temperature range (unless otherwise noted)⁽¹⁾

		MIN	MAX	UNIT
Voltage	VDD to GND	- 0.5	6	V
	SDA and SCL to GND	- 0.5	6	V
Current in to any pin			10	mA
T _J	Junction temperature		150	°C
T _{stg}	Storage temperature	- 65	150 ⁽²⁾	°C

- (1) Operation outside the Absolute Maximum Ratings may cause permanent device damage. Absolute Maximum Ratings do not imply functional operation of the device at these or any other conditions beyond those listed under Recommended Operating Conditions. If used outside the Recommended Operating Conditions but within the Absolute Maximum Ratings, the device may not be fully functional, and this may affect device reliability, functionality, performance, and shorten the device lifetime.
- (2) Long exposure to temperatures higher than 105°C can cause package discoloration, spectral distortion, and measurement inaccuracy.

7.2 ESD Ratings

			VALUE	UNIT
V _(ESD)	Electrostatic discharge	Human body model (HBM), per ANSI/ESDA/ JEDEC JS-001, all pins ⁽¹⁾	±2000	V
		Charged device model (CDM), per ANSI/ESDA/ JEDEC JS-002, all pins ⁽²⁾	±500	

- (1) JEDEC document JEP155 states that 500-V HBM allows safe manufacturing with a standard ESD control process.
- (2) JEDEC document JEP157 states that 250-V CDM allows safe manufacturing with a standard ESD control process.

7.3 Recommended Operating Conditions

over operating free-air temperature range (unless otherwise noted)

		MIN	NOM	MAX	UNIT
VDD	Supply voltage	1.6		3.6	V
T _J	Junction temperature	- 40		85	°C

7.4 Thermal Information

THERMAL METRIC ⁽¹⁾		OPT4048	UNIT
		DTS	
		8 Pins	
R _{θJA}	Junction-to-ambient thermal resistance	112.2	°C/W
R _{θJC(top)}	Junction-to-case (top) thermal resistance	28.4	°C/W
R _{θJB}	Junction-to-board thermal resistance	22.1	°C/W
Ψ _{JT}	Junction-to-top characterization parameter	1.2	°C/W
Ψ _{JB}	Junction-to-board characterization parameter	22	°C/W

- (1) For more information about traditional and new thermal metrics, see the [Semiconductor and IC Package Thermal Metrics](#) application report.

7.5 Electrical Characteristics

All specifications at TA = 25°C, VDD = 3.3 V, 100-ms conversion-time per channel, automatic full-scale range, white LED and normal-angle incidence of light, unless otherwise specified. Spec parameters are preliminary, subject to change over operating free-air temperature range (unless otherwise noted)

PARAMETER		TEST CONDITIONS	MIN	TYP	MAX	UNIT
Optical						
	Number of Channels			4		
λ_{peak}	Peak irradiance spectral responsivity	CH0 (X)		600		nm
		CH1(Y)		550		nm
		CH2(Z)		460		nm
		CH3(W)		500		nm
	ADC resolution		9		20	bits
	Range determination			3		bits
T_{intg}	Light Integration-time per channel ⁽⁴⁾	Conversion-time CT = 0x6		25		ms
		Conversion-time CT = 0xB		800		ms
R_{CH0}	Peak Responsivity	CH0 (X) Lowest auto gain range, 800 ms conversion time per channel		2770		codes per $\mu\text{W}/\text{cm}^2$
R_{CH1}		CH1 (Y) Lowest auto gain range, 800 ms conversion time per channel		3960		codes per $\mu\text{W}/\text{cm}^2$
R_{CH2}		CH2 (Z) Lowest auto gain range, 800 ms conversion time per channel		1910		codes per $\mu\text{W}/\text{cm}^2$
R_{CH3}		CH3 (W) Lowest auto gain range, 800 ms conversion time per channel		6950		codes per $\mu\text{W}/\text{cm}^2$
ER_{lux}	Equivalent Resolution	Lowest auto gain range, 100 ms conversion-time per channel		17.2		mlux
		Lowest auto gain range, 800 ms conversion-time per channel		2.15		mlux
E_{VFS}	Full-scale equivalent Illuminance			144284		lux
E_{v}	Measurement output result from lux measurement	2000 lux input ⁽¹⁾	1800	2000	2200	lux
	Relative accuracy between gain ranges ⁽²⁾	All channels		0.6		%
E_{VIR}	Infrared response ⁽⁶⁾	850nm near infra-red, all channels except for CH3 (W)		0.2		%
	Light source variation for lux measurement (incandescent, halogen, fluorescent)	Bare device, no cover glass		4		%
	Linearity	Input illuminance > 2254 lux , 100 ms conversion-time per channel, all channels		2		%
		Input illuminance <= 2254 lux , 100 ms conversion-time per channel, all channels		5		%
	Dark Measurement	All channels		0	10	codes
	Drift across temperature	CH0 (X)		0.02		%/°C
		CH1 (Y)		0.02		%/°C
		CH2 (Z)		0.05		%/°C
		CH3 (W)		0.05		%/°C

7.5 Electrical Characteristics (continued)

All specifications at TA = 25°C, VDD = 3.3 V, 100-ms conversion-time per channel, automatic full-scale range, white LED and normal-angle incidence of light, unless otherwise specified. Spec parameters are preliminary, subject to change over operating free-air temperature range (unless otherwise noted)

PARAMETER		TEST CONDITIONS	MIN	TYP	MAX	UNIT
	Angular response (FWHM)	CH0 (X)		134		°
		CH1 (Y)		121		°
		CH2 (Z)		99		°
		CH3 (W)		128		°
PSRR	Power-supply rejection ratio ⁽³⁾	VDD at 3.6 V and 1.6 V, 30 different sources, all channels		0.2		%/V
POWER SUPPLY						
V _{DD}	Power supply		1.6		3.6	V
V _{I2C}	Power supply for I ² C pull up resistor	I ² C pullup resistor, V _{DD} ≤ V _{I2C}	1.6		5.5	V
I _{QACTIVE}	Active Current	Dark		24		μA
		Full-scale lux		29		μA
I _Q	Quiescent current	Dark		2		μA
		Full-scale lux		2.6		μA
POR	Power-on-reset threshold			0.8		V
DIGITAL						
C _{IO}	I/O Pin Capacitance			3		pF
V _{IL}	Low-level input voltage (SDA, SCL, and ADDR)		0		0.3 X V _{DD}	V
V _{IH}	High-level input voltage (SDA, SCL, and ADDR)		0.7 X V _{DD}		5.5	V
I _{IL}	Low-level input current (SDA, SCL, and ADDR)			0.01	0.25 ⁽⁵⁾	μA
V _{OL}	Low-level output voltage (SDA and INT)	I _{OL} =3mA			0.32	V
I _{ZH}	Output logic high, high-Z leakage current (SDA, INT)	Measured with V _{DD} at pin		0.01	0.25 ⁽⁵⁾	μA
TEMPERATURE						
	Specified temperature range		- 40		85	°C

- (1) Tested with the white LED calibrated to 2000 lux.
- (2) Characterized by measuring fixed near-full-scale light levels on the higher adjacent full-scale range setting.
- (3) PSRR is the percent change of the measured lux output from the current value, divided by the change in power supply voltage, as characterized by results from 3.6-V and 1.6-V power supplies.
- (4) The conversion-time, from start of conversion until the data are ready to be read, is the integration-time plus analog-to-digital conversion-time.
- (5) The specified leakage current is dominated by the production test equipment limitations. Typical values are much smaller.
- (6) Tested with a near infrared LED of 850nm wavelength.

7.6 Typical Characteristics

At $T_A = 25^\circ\text{C}$, $V_{DD} = 3.3\text{ V}$, 800-ms conversion time (CONVERSION_TIME = 0xB), automatic full-scale range (RANGE = 0xC), white LED, and normal-angle incidence of light, unless otherwise specified.

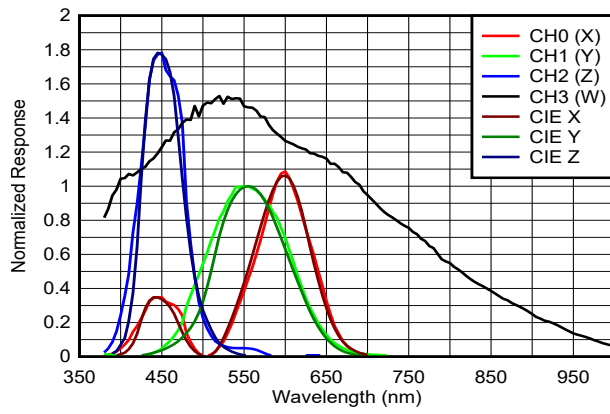

Channels measurements scaled to match CIE curves

图 7-1. Spectral Response vs Wavelength

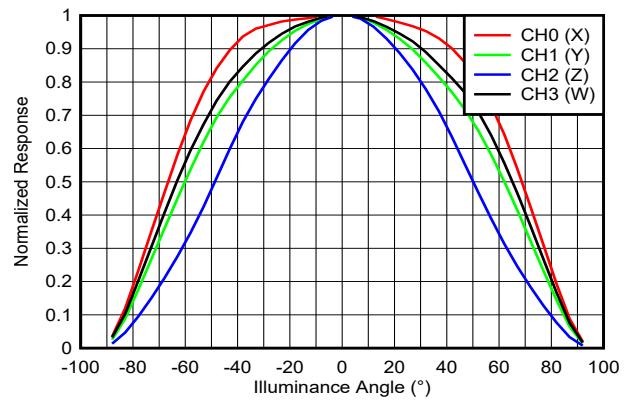

Normalized to 0°

图 7-2. Device Response vs Illuminance Angle

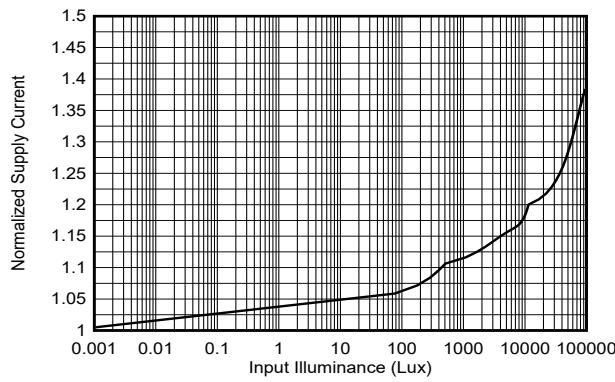

Normalized to dark condition

图 7-3. Active Current vs Input Light Level

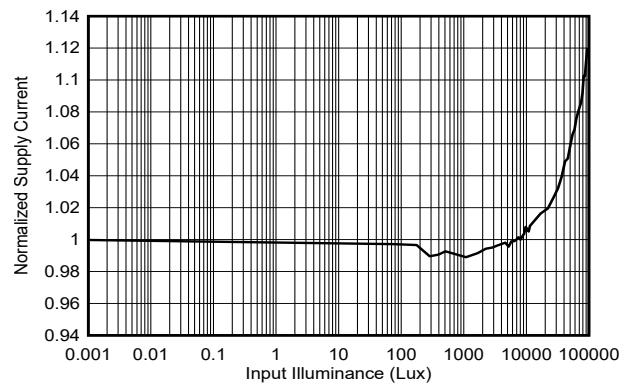

Normalized to dark condition

图 7-4. Standby Current vs Input Light Level

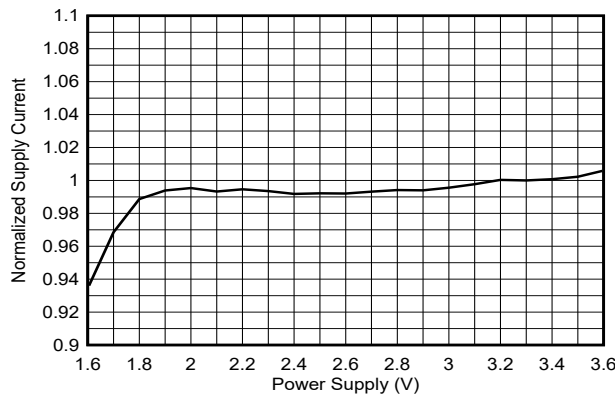

Normalized to 3.3 V

图 7-5. Active Current vs Power Supply

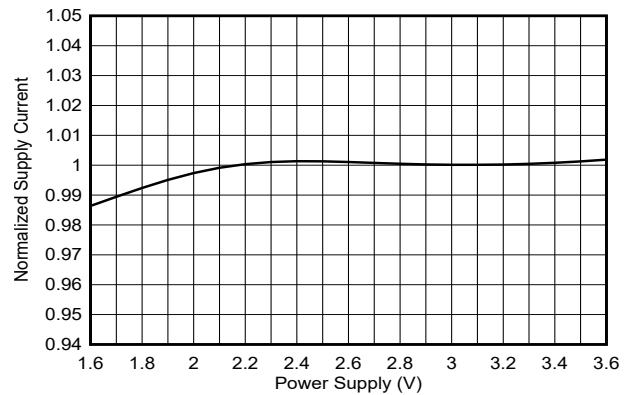

Normalized to 3.3 V

图 7-6. Standby Current vs Power Supply

7.6 Typical Characteristics (continued)

At $T_A = 25^\circ\text{C}$, $V_{DD} = 3.3\text{ V}$, 800-ms conversion time (CONVERSION_TIME = 0xB), automatic full-scale range (RANGE = 0xC), white LED, and normal-angle incidence of light, unless otherwise specified.

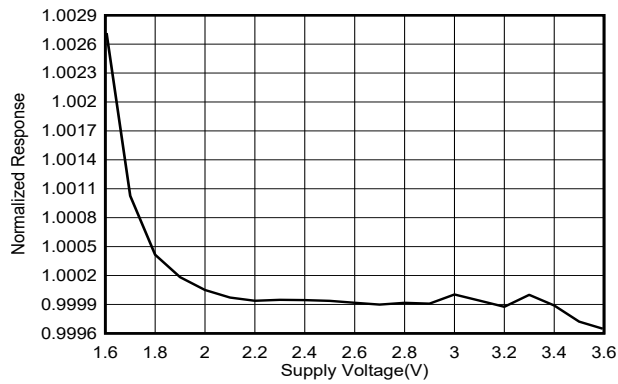

Normalized to 3.3 V

图 7-7. Device Response vs Power Supply

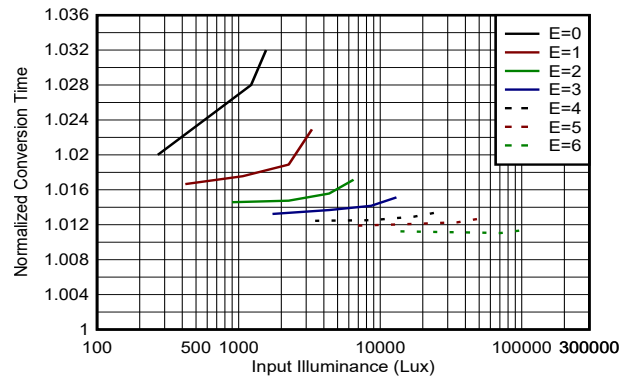

E denotes register EXPONENT_CHx

Normalized to 25 ms

图 7-8. Conversion Time at 25 ms per channel vs Input Light Level

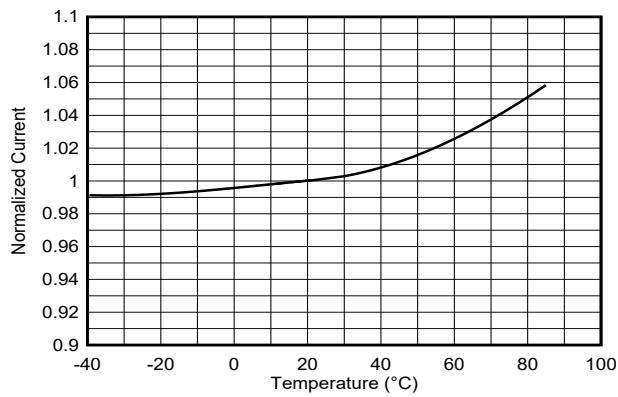

Normalized to 25°C

图 7-9. Active Current vs Temperature

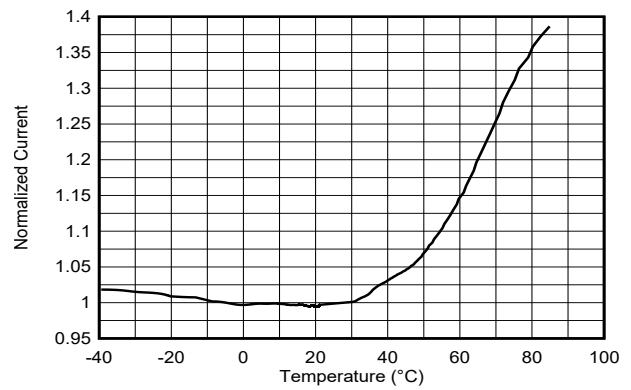

Normalized to 25°C

图 7-10. Standby Current vs Temperature

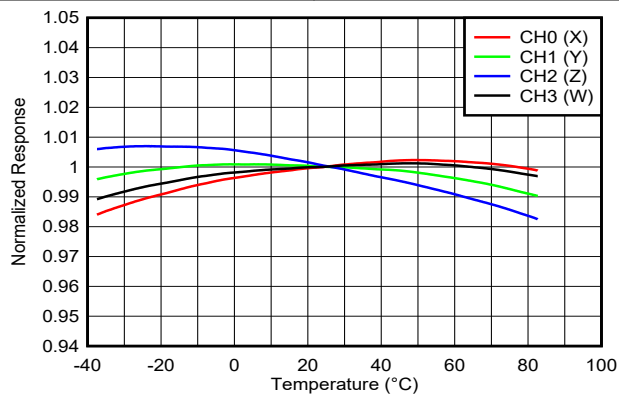

Normalized to 25°C

图 7-11. Device Response vs Temperature

8 Detailed Description

8.1 Overview

The OPT4048 measures the color properties of the light source that illuminates the device. This device measures four channels (X Channel, Y Channel, Z Channel, W Channel) with special spectral characteristics, which helps extract properties of the light source (i) the CIE XY/U'V' color coordinates (ii) the lux level and (iii) the correlated color temperature. Name of the channels correspond to the respective CIE tristimulus curves with additional W channel being the wide channel response.

With close matching to the CIE tristimulus spectral profiles, OPT4048 measures the true color of any light source or environment. This helps applications where, measuring the precise characteristics of the lighting environment is critical like display brightness, color temperature adjustment, camera color temperature correction, object true color recognition & medical applications.

Since CIE tristimulus curves are devised to mimic human color perception, matching the sensor spectral response to those curves is vital because color sensors are used to measure and help create excellent human lighting experiences. Strong rejection of infrared light, which a human does not see, is a crucial component of this matching. This matching makes the OPT4048 especially good for operation underneath windows that are visibly dark, but infrared transmissive

OPT4048 is fully self-contained to measure the properties of light and report the result in ADC codes digitally over the I²C bus. The result can also be used to alert a system and interrupt a processor with the INT pin. The result can also be summarized with a programmable threshold comparison with a specified channel and communicated with the INT pin.

OPT4048 is by default configured to operate in automatic full-scale range detection mode that always selects the best full-scale range setting for the given lighting conditions. There are 7 full-scale range settings, one of which can be selected manually as well. Setting the device to operate in automatic full-scale range detection mode frees the user from having to program their software for potential iterative cycles of measurement and readjustment of the full-scale range until good for any given measurement. With device exhibiting excellent linearity over the entire 26 bit dynamic range of measurement no additional linearity calibration is required at system level.

The OPT4048 contains 4 channels, results of which are always available all the time as independent channel registers which can be digitally read over the I²C bus synchronously or asynchronously.

The device measures light for 4 channels sequentially (X, Y, Z, W) with selectable conversion times from 600 μ s per channel to 800 ms per channel in 12 steps. Measurements can be read asynchronously or interrupt pin based which can be configured to generate an interrupt every time a single channel completes conversion or every time all 4 channels complete conversion.

The device starts up in a low-power shutdown state, such that the OPT4048 only consumes active-operation power after being programmed into an active state.

OPT4048 optical filtering system is not excessively sensitive to small particles and micro-shadows on the optical surface. This reduced sensitivity is a result of the relatively minor device dependency on uniform density optical illumination of the sensor area for infrared rejection. Proper optical surface cleanliness is always recommended for best results on all optical devices.

8.2 Functional Block Diagram

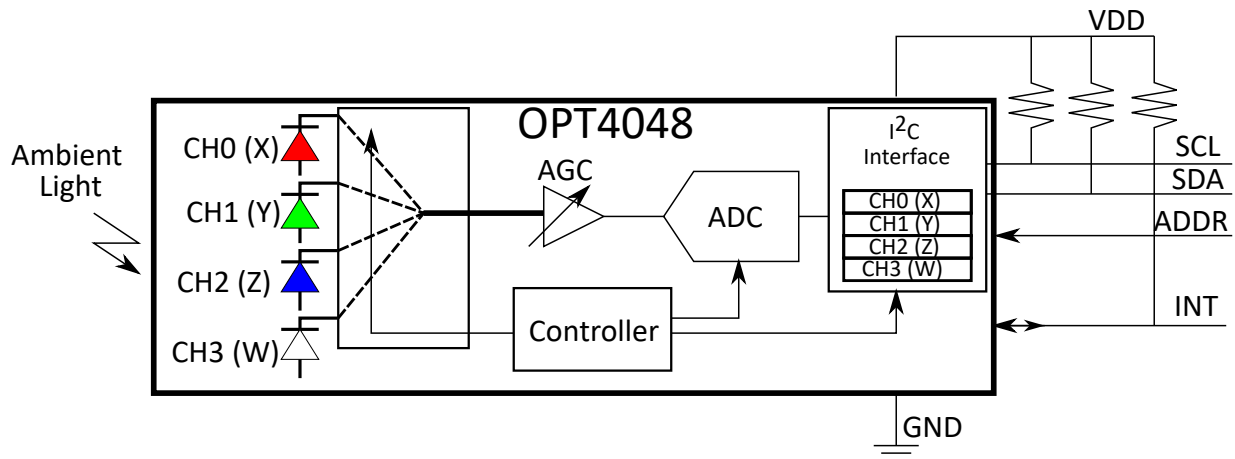

8.3 Feature Description

8.3.1 Spectral Matching to CIE

The OPT4048 spectral response closely matches CIE 1931 tristimulus spectra, which is modeled to be a close representation of how an average human perceives light. This is crucial to measure the characteristics of light such as color, intensity as close as possible to how humans perceive.

OPT4048 also has excellent infrared light (IR) rejection. This IR rejection is especially important because many real-world lighting sources have significant infrared content that humans do not see. If the sensor measures infrared light that the human eye does not see, then a true human experience is not accurately represented.

If the application demands hiding OPT4048 underneath dark window (such that the end-product user cannot see the sensor) the infrared rejection of the OPT4048 becomes significantly more important because many dark windows attenuate visible light but transmit infrared light. This attenuation of visible light and lack of attenuation of IR light amplifies the ratio of the infrared light to visible light that illuminates the sensor. Results can still be well matched to the human eye under this condition because of the high infrared rejection of the OPT4048.

8.3.2 Automatic Full-Scale Range Setting

The OPT4048 has an automatic full-scale range setting feature that eliminates the need to predict and set the best range for the device. Each channel has an auto-scaling algorithm and independently tracks light levels. In this mode, the OPT4048 automatically selects the best full-scale range for the given lighting condition. The OPT4048 has a high degree of result matching between the full-scale range settings. This matching eliminates the problem of varying results or the need for range-specific, user-calibrated gain factors when different full-scale ranges are chosen. The device has independent range detection logic making the device operate seamlessly with a wide range of light color and levels.

8.3.3 Output Register CRC and Counter

OPT4048 device features additional bits as part of the output register which helps in improving the reliability of light measurements for the application.

8.3.3.1 Output Sample Counter

The OPT4048 device features registers `COUNTER_CHx` as part of the output registers which increments for every successful measurement. This register can be read as part of the output registers which helps the application to keep track of measurements. The 4 bit counter starts at 0 on power-up and counts up to 15 after which the counter resets back to 0 and continues to count up. There are independent counters for each channel counting up every successful conversion.

- Host or the controller needs consecutive measurements. Utilizing the `COUNTER_CHx` registers allow the controller to compare samples and makes sure that the samples are in expected order without missing intermediate counter values.

- As a safety feature where when light level are not changing, the controller can make sure that the measurements from OPT4048 are not stuck by comparing values of registers [COUNTER_CHx](#) between measurements. If the [COUNTER_CHx](#) values continue to change over samples, the device is updating the output register with the most recent measurement of light levels.

8.3.3.2 Output CRC

[CRC_CHx](#) registers consists of Cyclic Redundancy Checker bits part of the output registers calculated within the OPT4048 device and updated on every measurement. This feature helps in detecting communication related bit errors during the output readout from the device. The calculation method for the CRC bits is shown in the [Figure 8-12](#), which can be independently verified in the controller or host firmware/software to validate if communication between the controller and the device was successful without bit errors during transmission.

8.3.3.3 Threshold Detection

OPT4048 features a threshold detection logic which can be programmed to indicate and update register flags if measured light levels cross thresholds set by the user. The threshold condition can be programmed to use one of the 4 channels as trigger determined by the [THRESHOLD_CH_SEL](#) register. There are independent low and high threshold target registers with independent flag registers to indicate the status of measured light level. Measured light level reaching below low threshold and above the high threshold are called faults. Users can program a fault count register, which counts consecutive number of faults before the flag registers are set. Details on the register and setting up the threshold is available in [Section 8.3.4.2](#) and [Section 8.3.4.5](#).

8.3.4 Device Functional Modes

8.3.4.1 Modes of Operation

OPT4048 has [output registers](#) which are always available to readout to get measurements, the measurements themselves are updated based on the device mode of operation listed below. The OPT4048 device has the following modes of operation:

- **Power-down mode:** This is power-down or standby mode where the device enters a low power state. There is no active light sensing or conversion in this mode. Device still responds to I²C transactions which can be utilized to bring the device out of this mode.
- **Continuous mode:** In this mode OPT4048 measures all 4 channels in a round robin fashion continuously and updates their corresponding output registers. The conversion time register [CONVERSION_TIME](#) determines the time between each channel conversion and a hardware interrupt on pin INT is generated for every successful conversion on each channel or all 4 channels depending on [INT_CFG](#) register value. TI recommends to configure the INT pin in output mode using the [INT_DIR](#) register. The device active circuits are continuously kept active to minimize the interval between measurements.
- **One shot mode of operation:** There are several ways in which OPT4048 can be used in one shot mode of operation with one common theme which is that OPT4048 stays in standby mode and a conversion is triggered by a register write either by a register write to configuration register or hardware interrupt on the INT pin. Every trigger generates one measurement for 4 channels, effectively taking four times the time set by the [CONVERSION_TIME](#) register

There are two types of one shot modes.

- **Force auto-range one shot mode:** Every one shot trigger forces a full reset on auto-ranging control logic and a fresh auto-range detection is initiated ignoring the previous measurements. This is particularly useful in situation where lighting conditions are expected to change a lot and one shot trigger frequency is not very often. There is small penalty on conversion time due for the auto-ranging logic to recover from reset state. The full reset cycle on the auto-ranging control logic takes around 500 μ s which needs to be accounted for between measurements when this mode is used.
- **Regular auto-range one shot mode:** Auto-range selection logic utilizes the information from the previous measurements to decide on range for the current trigger. This mode is recommended only when the device needs time synchronized measurements with frequent triggers from the controller. In other words, this mode can be used as an alternative to continuous mode the key difference being that the interval between measurements is determined by the one shot triggers.

One Shot can be triggered using by the following:

- **Hardware trigger:** INT pin can be configured to be an input to trigger a measurement using [INT_DIR](#) register. Since INT pin is used as input, there is no hardware interrupt to indicate completion of measurement. The controller needs to keep time from the trigger mechanism and read out output registers.
- **Register trigger:** An I²C write to the M register triggers a measurement. The register value is reset after a successful measurement. INT pin can be configured to indicate measurement completion to read out output registers using the [INT_DIR](#) register.

TI highly recommends to set the interval between subsequent triggers to account for all the aspects involved in the trigger mechanism like the I²C transaction time, device wake-up time, auto-range time (if used) and 4 times the device conversion time.

Since the device enters standby after each one shot trigger, measurement interval on the one shot trigger mechanism needs to account for additional time T_{ss} as specified in the specification table for the circuits to recover from standby state. However setting the quick wake up register QWAKE eliminates the need for this additional T_{ss} at the cost of not powering down the active circuit with device not entering the standby mode between triggers.



图 8-1. Timing Diagrams for different Operating modes

8.3.4.2 Interrupt Modes of Operation

The device has an interrupt reporting system that allows the processor connected to the I²C bus to go to sleep, or otherwise ignore the device results, until a user-defined event occurs that requires possible action. Alternatively, this same mechanism can also be used with any system that can take advantage of a single digital signal that indicates whether the light is above or below levels of interest.

Channel on which this behavior can be enabled is set by the register [THRESHOLD_CH_SEL](#).

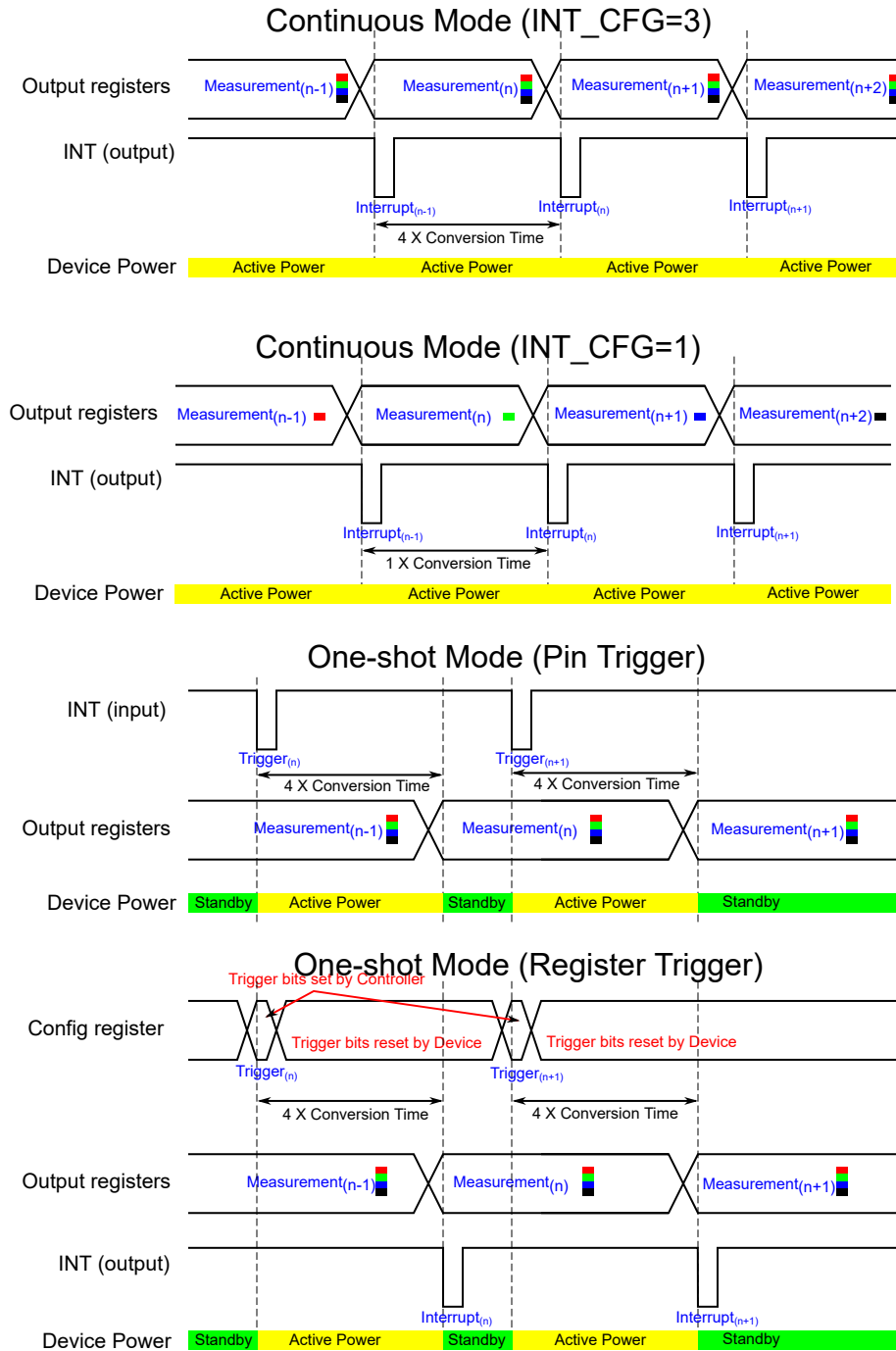
The INT pin has an open-drain output, which requires the use of a pull-up resistor. This open-drain output allows multiple devices with open-drain INT pins to be connected to the same line, thus creating a logical *NOR* or *AND* function between the devices. The polarity of the INT pin can be controlled by the `INT_POL`.

There are two major types of interrupt reporting mechanism modes: latched window comparison mode and transparent hysteresis comparison mode. The configuration register `LATCH` controls which of these two modes is used. 图 8-2 和 表 8-1 summarize the function of these two modes. Additionally, the INT pin can either be used to indicate a fault in one of these modes (`INT_CFG=0`) or to indicate a conversion completion (`INT_CFG >0`). This is shown in 表 8-2.



图 8-2. Interrupt Pin Status (for `INT_CFG=0` setting) and Register Flag Behavior

表 8-1. Interrupt Pin Status (for `INT_CFG=0` setting) and Register Flag Behavior

LATCH Setting	INT Pin State (when <code>INT_CFG=0</code>)	FLAG_H Value	FLAG_L Value	Latching Behavior
0: Transparent hysteresis mode	INT pin indicates if measurement is above (INT active) or below (INT inactive) the threshold. If measurement is between the high and low threshold values then the previous INT value is maintained. This prevents the INT pin from repeated toggling when the measurement values are close to the threshold.	0: If measurement is below the low limit 1: If measurement is above the high limit If measurement is between high and low limits previous value is maintained	0: If measurement is above the high limit 1: If measurement is below the low limit If measurement is between high and low limits previous value is maintained	Not latching: Values are updated after each conversion
1: Latched window mode	INT pin becomes active if the measurement is outside the window (above high threshold or below the low threshold). The INT pin does not reset and return to the inactive state until register 0xC is read.	1: If measurement is above the high limit	1: If measurement is below the low limit	Latching: INT pin, FLAG_H and FLAG_L values do not reset until the register 0x0C is read.

The `THRESHOLD_H`, `THRESHOLD_L`, `LATCH` and `FAULT_COUNT` registers control the interrupt behavior. The `LATCH` field setting allows a choice between the latched window mode and transparent hysteresis mode as shown in the table. Interrupt reporting can be observed on INT pin, the `FLAG_H`, and the `FLAG_L` registers.

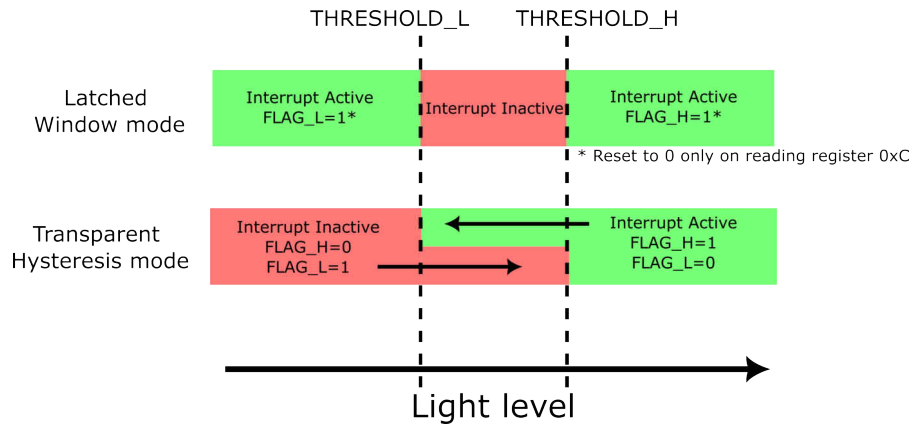
Results from comparing the current sensor measurements with `THRESHOLD_H` and `THRESHOLD_L` registers are referred to as *fault events*. The calculations to set these registers can be found in 节 8.3.4.5. The `FAULT_COUNT` register dictates the number of continuous *fault events* required to trigger an interrupt event and subsequently change the state of the interrupt reporting mechanisms. For example, with a `FAULT_COUNT` value

of 2 corresponding to 4 fault counts, the INT pin, [FLAG_H](#) and [FLAG_L](#) states shown in the table are not realized unless 4 consecutive measurements are taken that satisfy the fault condition.

INT pin function listed in [表 8-1](#) is valid only when [INT_CFG=0](#). The INT pin function can be changed to indicate an end of conversion as well shown in [表 8-2](#). The [FLAG_H](#) and [FLAG_L](#) registers continue to behave as listed in [表 8-1](#) even while [INT_CFG>0](#). The polarity of the INT pin is controlled by the [INT_POL](#) register.

表 8-2. INT_CFG Setting and Resulting INT Pin Behavior

INT_CFG Setting	INT Pin Function
0	As per 表 8-1
1	INT pin asserted with 1us pulse width after conversion of every channel
3	INT pin asserted with 1us pulse width every 4 conversions to indicate all channel measurements are complete

8.3.4.3 Light Range Selection

The OPT4048 has an automatic full-scale-range setting mode that eliminates the need for a user to predict and set the best range for the device. This mode is entered when register [RANGE](#) is set to 0xC. The device determines the appropriate full-scale range to take the measurement based on a combination of current lighting conditions and the previous measurement.

If a measurement is towards the low side of full-scale, then the full-scale range is decreased by one or two settings for the next measurement. If a measurement is towards the upper side of full-scale, the full-scale range is increased by one setting for the next measurement.

If the measurement exceeds the full-scale range, resulting from a fast increasing optical transient event, then the current measurement is aborted. This invalid measurement is not reported. If the scale is not at the maximum, then the device increases the scale by one step and a new measurement is retaken with that scale. Therefore, during a fast increasing optical transient in this mode, a measurement can possibly take longer to complete and report than indicated by the configuration register [CONVERSION_TIME](#).

The logic that determines the appropriate range settings for each channel is independent of each other, which verifies a support of a wide range of colors represented with the best accuracy.

TI highly recommends to use this feature, since the device selects the best range setting based on lighting condition. However, there is an option to manually set the range. Setting the range manually turns off the automatic full-scale selection logic and the device operates for a particular range setting.

表 8-3. Range Selection Table

RANGE register setting	Typical Full-scale Light level
0	2254 lux
1	4509 lux
2	9018 lux
3	18036 lux
4	36071 lux
5	72142 lux
6	144284 lux
12	Determined by automatic full-scale range logic

8.3.4.4 Selecting Conversion Time

OPT4048 device offers several conversion times to select from. Conversion Time is defined as the time to take for one measurement to complete for one channel and update the results in output register. Since OPT4048 is 4 channel device the actual time to complete a 4 channel measurement is 4 times the time specified in the [CONVERSION_TIME](#) register. Measurement initiation is determined by the mode of operation as specified in [节 8.3.4.1](#).

表 8-4. Conversion Time Selection

CONVERSION_TIME Register	Typical Conversion Time Per Channel
0	600 μs
1	1 ms
2	1.8 ms
3	3.4 ms
4	6.5 ms
5	12.7 ms
6	25 ms
7	50 ms
8	100 ms
9	200 ms
10	400 ms
11	800 ms

8.3.4.5 Light and Color Measurement

The OPT4048 device measures light on 4 independent channels and updates output registers with proportional ADC codes. Updated are based on the mode of operation as described in 节 8.3.4.1. If readout of output registers is performed before a successful completion of a measurement, the previous measurement is what would be read out. Output of the each channel is represented by two parts (i) 4 bits of EXPONENT_CHx and (ii) 20 bits of MANTISSA_CHx. This arrangement of binary logarithmic full-scale range with linear representation within a range, helps in covering a large dynamic range of measurements. MANTISSA here represents the linear ADC codes proportional to the measured light within a given full-scale range and the EXPONENT_CHx represents the current-full scale range selected. The selected range can be automatically determined by the auto-range selection logic or manually selected as per 表 8-3.

Lux level can be determined using the following equations:

$$\text{MANTISSA_CHx} = (\text{RESULT_MSB_CHx} \ll 8) + \text{RESULT_LSB_CHx} \quad (1)$$

or

$$\text{MANTISSA_CHx} = (\text{RESULT_MSB_CHx} \times 2^8) + \text{RESULT_LSB_CHx} \quad (2)$$

where RESULT_MSB_CHx, RESULT_LSB_CHx and EXPONENT_CHx are registers part of the output register for each channel

RESULT_MSB_CHx register carries the most significant 12 bits of the MANTISSA_CHx and RESULT_LSB_CHx register carries the least significant 8 bits of the MANTISSA_CHx. MANTISSA_CHx is then computed using the above equations to get the 20 bit number. EXPONENT_CHx is directly read from the register which is 4 bits.

Once the EXPONENT_CHx and MANTISSA_CHx portions are calculated the linearized ADC_CODES_CHx is calculated using the following equation:

$$\text{ADC_CODES_CHx} = (\text{MANTISSA_CHx} \ll \text{EXPONENT_CHx}) \quad (3)$$

or

$$\text{ADC_CODES_CHx} = (\text{MANTISSA_CHx} \times 2^{\text{EXPONENT_CHx}}) \quad (4)$$

With maximum value for register EXPONENT_CHx being 8 ADC_CODES is effectively a 28 bit number. The semi-logarithmic numbers have been converted to a linear ADC_CODES_CHx representation making simple to convert to lux and CIE XY color coordinates

Conversion of the raw ADC codes to the CIE colorimetric X, Y and lux are given by the equation below

$$[adc_codes_ch0 \quad adc_codes_ch1 \quad adc_codes_ch2 \quad adc_codes_ch3] \cdot \begin{bmatrix} m0x & m0y & m0z & m0l \\ m1x & m1y & m1z & m1l \\ m2x & m2y & m2z & m2l \\ m3x & m3y & m3z & m3l \end{bmatrix} = [x \quad y \quad z \quad lux] \quad (5)$$

$$CIE_x = \frac{x}{x + y + z} \quad (6)$$

$$CIE_y = \frac{y}{x + y + z} \quad (7)$$

The conversion matrix can be customized based on target application and details for the same can be found in [节 9.2.4](#).

Lux Calculations

As listed in the [方程式 5](#) lux values can be obtained along with the color information as part of the matrix. However, isolating the lux calculations from the matrix can be useful. In that case, the matrix can be simplified to remove lux calculations as shown below

$$[adc_codes_ch0 \quad adc_codes_ch1 \quad adc_codes_ch2 \quad adc_codes_ch3] \cdot \begin{bmatrix} m0x & m0y & m0z \\ m1x & m1y & m1z \\ m2x & m2y & m2z \\ m3x & m3y & m3z \end{bmatrix} = [x \quad y \quad z] \quad (8)$$

Lux can be simply calculated using the following equation

$$lux = adc_codes_ch1 \times 2.15e-3 \quad (9)$$

Threshold Detection Calculations

Threshold result registers [THRESHOLD_H_RESULT](#) and [THRESHOLD_L_RESULT](#) are 12 bit, while threshold exponent registers [THRESHOLD_H_EXPONENT](#) and [THRESHOLD_L_EXPONENT](#) are 4 bits. Since threshold is compared at linear [ADC_CODES_CHx](#), the threshold registers are padded with zeros internally as shown to compare with the [ADC_CODES_CHx](#)

$$ADC_CODES_TH = THRESHOLD_H_RESULT \ll (8 + THRESHOLD_H_EXPONENT) \quad (10)$$

or

$$ADC_CODES_TH = THRESHOLD_H_RESULT \times 2^{(8 + THRESHOLD_H_EXPONENT)} \quad (11)$$

and

$$ADC_CODES_TL = THRESHOLD_L_RESULT \ll (8 + THRESHOLD_L_EXPONENT) \quad (12)$$

or

$$ADC_CODES_TL = THRESHOLD_L_RESULT \times 2^{(8 + THRESHOLD_L_EXPONENT)} \quad (13)$$

Threshold are then compared as shown to detect Fault events.

$$\text{If } ADC_CODES_CHx < ADC_CODES_TL \text{ a Fault Low is detected} \quad (14)$$

and

$$\text{If } ADC_CODES_CHx > ADC_CODES_TH \text{ a Fault High is detected} \quad (15)$$

Based on the [FAULT_COUNT](#) register setting, with consecutive Fault High or Fault Low events, respective [FLAG_H](#) and [FLAG_L](#) registers are set. Clearly understanding the difference between [THRESHOLD_H_EXPONENT](#), [THRESHOLD_H_RESULT](#), [THRESHOLD_L_EXPONENT](#), [THRESHOLD_L_RESULT](#) and the output registers is important to be able to set appropriate threshold based on application needs. More details can be found in [节 8.3.4.2](#).

8.3.4.6 Light Resolution

The OPT4048 device's effective resolution is dependent on both the conversion time setting and the full-scale light range. Although the LSB resolution of the linear [ADC_CODES](#) doesn't change, the effective or useful resolution of the device is dependent on the conversion time setting and the full-scale range as per the table below. In conversion times where the effective resolution is lower, the LSBs are padded with 0.

表 8-5. Resolution Table

CONVERSION_TIME register	Conversion Time	MANTES SA effective bits	EXPONENT	0	1	2	3	4	5	6
			Full-scale lux	2254	4509	9018	18036	36071	72142	144284
			Effective Resolution in lux							
0	600 us	9		4.4	8.8	17.6	35.2	70.45	140.9	281.8
1	1 ms	10		2.2	4.4	8.8	17.6	35.2	70.45	140.9
2	1.8 ms	11		1.1	2.2	4.4	8.8	17.6	35.2	70.45
3	3.4 ms	12		550.4 m	1.1	2.2	4.4	8.8	17.6	35.2
4	6.5 ms	13		275.2 m	550.4 m	1.1	2.2	4.4	8.8	17.6
5	12.7 ms	14		137.6 m	275.2 m	550.4 m	1.1	2.2	4.4	8.8
6	25 ms	15		68.8 m	137.6 m	275.2 m	550.4 m	1.1	2.2	4.4
7	50 ms	16		34.4 m	68.8 m	137.6 m	275.2 m	550.4 m	1.1	2.2
8	100 ms	17		17.2 m	34.4 m	68.8 m	137.6 m	275.2 m	550.4 m	1.1
9	200 ms	18		8.6 m	17.2 m	34.4 m	68.8 m	137.6 m	275.2 m	550.4 m
10	400 ms	19		4.30 m	8.6 m	17.2 m	34.4 m	68.8 m	137.6 m	275.2 m
11	800 ms	20		2.15 m	4.30 m	8.6 m	17.2 m	34.4 m	68.8 m	137.6 m

As shown in the table above the resolution of the device is dependent on the [CONVERSION_TIME](#) and full-scale range. A similar scaling applies to the peak responsivity for each channel.

8.3.4.7 Programming

The OPT4048 supports the transmission protocol for standard mode (up to 100 kHz), fast mode (up to 400 kHz), and high-speed mode (up to 2.6 MHz). Fast and standard modes are described as the default protocol, referred to as *F/S*. High-speed mode is described in the [节 8.3.4.7.2.1](#).

8.3.4.7.1 I²C Bus Overview

The OPT4048 offers compatibility with both I²C and SMBus interfaces. The I²C and SMBus protocols are essentially compatible with one another. The I²C interface is used throughout this document as the primary example with the SMBus protocol specified only when a difference between the two protocols is discussed.

The device is connected to the bus with two pins: an SCL clock input pin and an SDA open-drain bidirectional data pin. The bus must have a controller device that generates the serial clock (SCL), controls the bus access, and generates start and stop conditions. To address a specific device, the controller initiates a start condition by pulling the data signal line (SDA) from a high logic level to a low logic level while SCL is high. All targets on the bus shift in the target address byte on the SCL rising edge, with the last bit indicating whether a read or write operation is intended. During the ninth clock pulse, the target being addressed responds to the controller by generating an acknowledge bit by pulling SDA low.

Data transfer is then initiated and eight bits of data are sent, followed by an acknowledge bit. During data transfer, SDA must remain stable while SCL is high. Any change in SDA while SCL is high is interpreted as a start or stop condition. When all data are transferred, the controller generates a stop condition, indicated by

pulling SDA from low to high while SCL is high. The device includes a 28-ms timeout on the I²C interface to prevent locking up the bus. If the SCL line is held low for this duration of time, the bus state machine is reset.

8.3.4.7.1.1 Serial Bus Address

To communicate with the OPT4048, the controller must first initiate an I²C start command. Then, the controller must address target devices via a target address byte. The target address byte consists of a seven bit address and a direction bit that indicates whether the action is to be a read or write operation.

Four I²C addresses are possible by connecting the ADDR pin to one of four pins: GND, VDD, SDA, or SCL. Table below summarizes the possible addresses with the corresponding ADDR pin configuration. The state of the ADDR pin is sampled on every bus communication and must be driven or connected to the desired level before any activity on the interface occurs.

ADDR PIN CONNECTION	DEVICE I ² C ADDRESS
GND	1000100
VDD	1000101
SDA	1000110
SCL	1000101

8.3.4.7.1.2 Serial Interface

The OPT4048 operates as a target device on both the I²C bus and SMBus. Connections to the bus are made via the SCL clock input line and the SDA open-drain I/O line. The device supports the transmission protocol for standard mode (up to 100 kHz), fast mode (up to 400 kHz), and high-speed mode (up to 2.6 MHz). All data bytes are transmitted most-significant bits first.

The SDA and SCL pins feature integrated spike-suppression filters and Schmitt triggers to minimize the effects of input spikes and bus noise. See the [节 9.2.1](#) for further details of the I²C bus noise immunity.

8.3.4.7.2 Writing and Reading

Accessing a specific register on the OPT4048 is accomplished by writing the appropriate register address during the I²C transaction sequence. Refer to [节 8.4](#) for a complete list of registers and their corresponding register addresses. The value for the register address (as shown in [节 8.4](#)) is the first byte transferred after the target address byte with the R/W bit low.



图 8-3. Setting the I²C Register Address

Writing to a register begins with the first byte transmitted by the controller. This byte is the target address with the R/W bit low. The device then acknowledges receipt of a valid address. The next byte transmitted by the controller is the address of the register that data are to be written to. The next two bytes are written to the register addressed by the register address. The device acknowledges receipt of each data byte. The controller can terminate the data transfer by generating a start or stop condition.

When reading from the device, the last value stored in the register address by a write operation determines which register is read during a read operation. To change the register address for a read operation, a new partial I²C write transaction must be initiated. This partial write is accomplished by issuing a target address byte with the R/W bit low, followed by the register address byte and a stop command. The controller then generates a start condition and sends the target address byte with the R/W bit high to initiate the read command. The next byte is transmitted by the target and is the most significant byte of the register indicated by the register address. This byte is followed by an acknowledge from the controller; then the target transmits the least significant byte. The controller acknowledges receipt of the data byte. The controller can terminate the data transfer by generating a not-acknowledge after receiving any data byte, or by generating a start or stop condition. If repeated reads from the same register are desired, continually sending the register address bytes is not necessary; the device retains the register address until that number is changed by the next write operation.

图 8-4 and 图 8-5 show the write and read operation timing diagrams, respectively. Note that register bytes are sent most significant byte first, followed by the least significant byte.

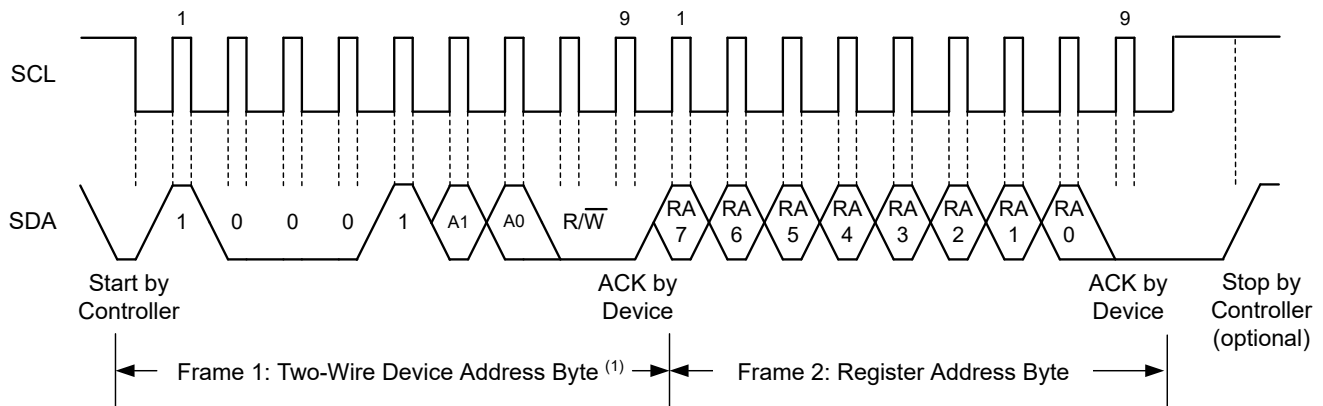

图 8-4. I²C Write Example



A. An ACK by the controller can also be sent.

图 8-5. I²C Read Example

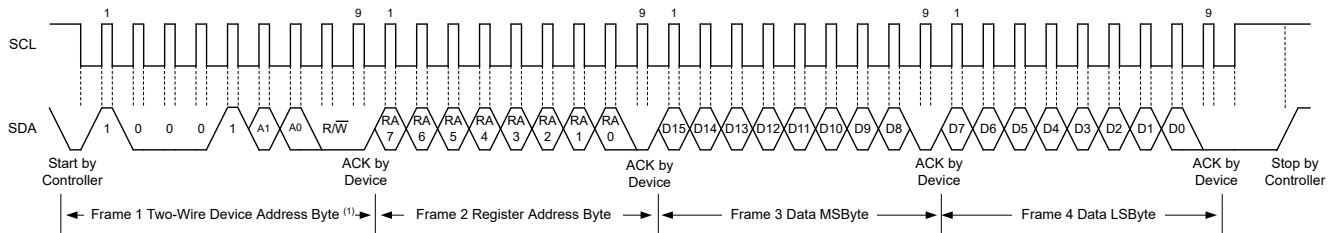
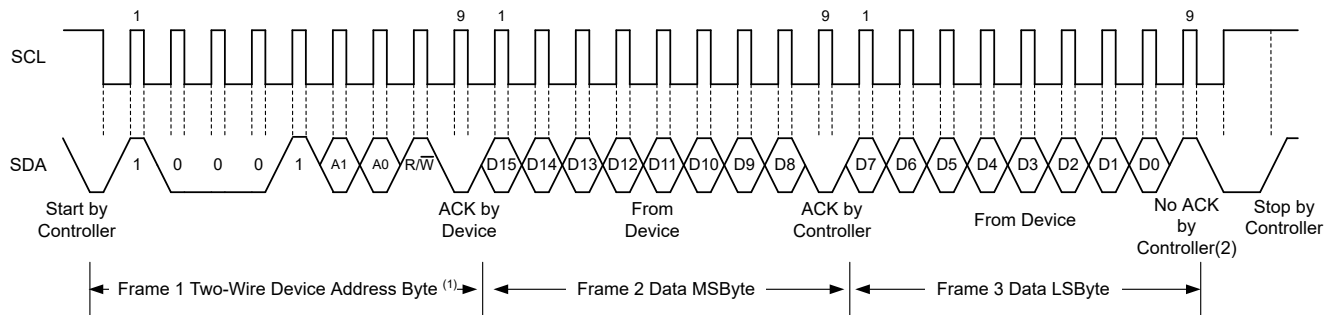
8.3.4.7.2.1 High-Speed I²C Mode

When the bus is idle, both the SDA and SCL lines are pulled high by the pullup resistors or active pullup devices. The controller generates a start condition followed by a valid serial byte containing the high-speed (HS) controller code 0000 1XXXb. This transmission is made in either standard mode or fast mode (up to 400 kHz). The device does not acknowledge the HS controller code but does recognize the code and switches the internal filters to support a 2.6-MHz operation.

The controller then generates a repeated start condition (a repeated start condition has the same timing as the start condition). After this repeated start condition, the protocol is the same as F/S mode, except that transmission speeds up to 2.6 MHz are allowed. Instead of using a stop condition, use repeated start conditions to secure the bus in HS mode. A stop condition ends the HS mode and switches all internal filters of the device to support the F/S mode.

8.3.4.7.2.2 Burst Read Mode

OPT4048 supports I²C burst read mode which helps in minimizing the number of transactions on the bus for efficient data transfer from the device to the controller.

Before considering the burst mode, a regular I²C read transaction involves an I²C write operation to the device read pointer, followed by the actual I²C read operation. With the output registers in continuous locations, writing the register pointer every 2 bytes takes up several clock cycles. With the burst mode enabled, the read pointer address is auto incremented after every register read (2 bytes), eliminating the need write operations to set the pointer for subsequent register reads.

Burst mode can be enabled by setting the register `I2C_BURST`. When a STOP command is issued the pointer resets to the original register address before the auto-increments.



图 8-6. I²C Operations

8.3.4.7.2.3 General-Call Reset Command

The I²C general-call reset allows the host controller in one command to reset all devices on the bus that respond to the general-call reset command. The general call is initiated by writing to the I²C address 0 (0000 0000b). The reset command is initiated when the subsequent second address byte is 06h (0000 0110b). With this transaction, the device issues an acknowledge bit and sets all registers to the power-on-reset default condition.

8.3.4.7.2.4 SMBus Alert Response

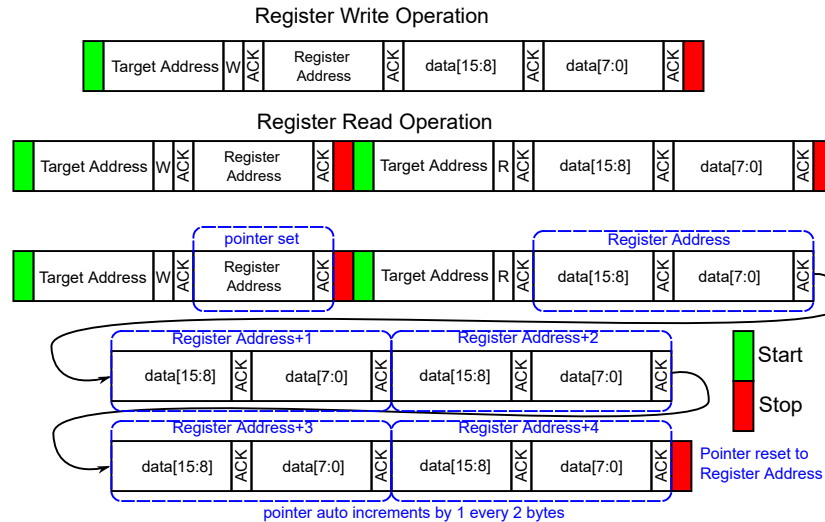
The SMBus alert response provides a quick identification for which device issued the interrupt. Without this alert response capability, the processor does not know which device pulled the interrupt line when there are multiple target devices connected.

OPT4048 is designed to respond to the SMBus alert response address, when in the latched window-style comparison mode. The OPT4048 does not respond to the SMBus alert response when in transparent mode.

The response behavior of the device to the SMBus alert response is shown in 图 8-7. When the interrupt line to the processor is pulled to active, the controller can broadcast the alert response target address. Following this alert response, any target devices that generated an alert identify themselves by acknowledging the alert response and sending respective I²C address on the bus. The alert response can activate several different target devices simultaneously. If more than one target attempts to respond, bus arbitration rules apply. The device with the lowest address wins the arbitration. If the OPT4048 loses the arbitration, the device does not acknowledge the I²C transaction and the INT pin remains in an active state, prompting the I²C controller processor to issue a subsequent SMBus alert response. When the OPT4048 wins the arbitration, the device acknowledges the transaction and sets the INT pin to inactive. The controller can issue that same command again, as many times as necessary to clear the INT pin. See 节 8.3.4.2 for additional details of how the flags and INT pin are controlled. The controller can obtain information about the source of the OPT4048 interrupt from the address broadcast in the above process. The `FLAG_H` value is sent as the final LSB of the address to provide the controller additional information about the cause of the OPT4048 interrupt. If the controller requires additional information, the result register or the configuration register can be queried. The `FLAG_Hand` `FLAG_L` registers are not cleared upon an SMBus alert response.

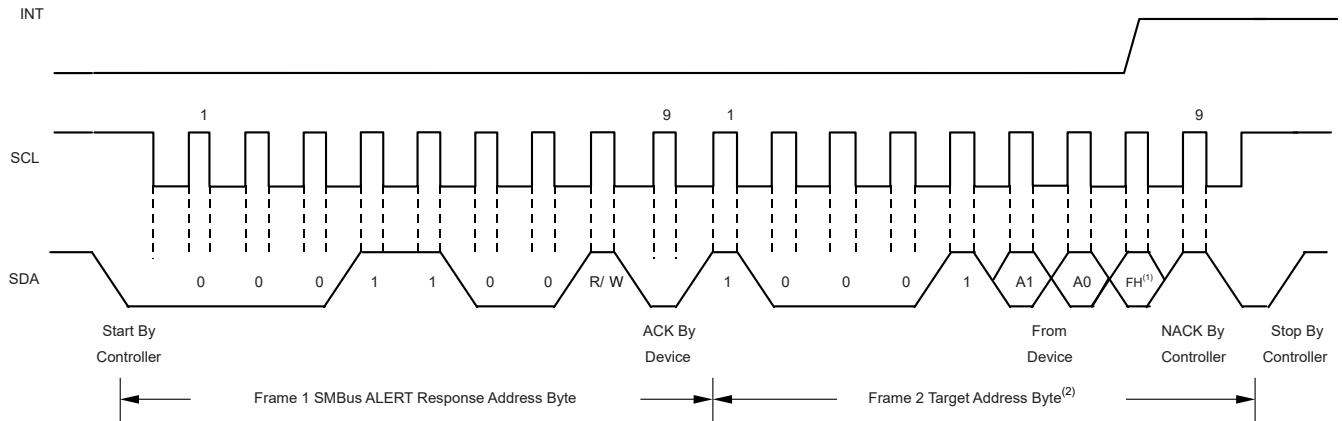

- A. FH is the [FLAG_H](#) register
- B. A1 and A0 are determined by the ADDR pin

图 8-7. Timing Diagram for SMBus Alert Response

8.4 Register Maps

图 8-8. ALL Register Map

ADD	D15	D14	D13	D12	D11	D10	D9	D8	D7	D6	D5	D4	D3	D2	D1	D0
00h	EXPONENT_CH0					RESULT_MSB_CH0										
01h	RESULT_LSB_CH0					COUNTER_CH0					CRC_CH0					
02h	EXPONENT_CH1					RESULT_MSB_CH1										
03h	RESULT_LSB_CH1					COUNTER_CH1					CRC_CH1					
04h	EXPONENT_CH2					RESULT_MSB_CH2										
05h	RESULT_LSB_CH2					COUNTER_CH2					CRC_CH2					
06h	EXPONENT_CH3					RESULT_MSB_CH3										
07h	RESULT_LSB_CH3					COUNTER_CH3					CRC_CH3					
08h	THRESHOLD_L_EXPONENT					THRESHOLD_L_RESULT										
09h	THRESHOLD_H_EXPONENT					THRESHOLD_H_RESULT										
0Ah	QWAKE	0	RANGE				CONVERSION_TIME				OPERATING_MODE		LATCH	INT_POL	FAULT_COUNT	
0Bh	128					THRESHOLD_CH_SEL		INT_DIR		INT_CFG			0	I2C_BURST		
0Ch	0					OVERLOAD_FLAG		CONVERSION_READY_FLAG		FLAG_H		FLAG_L				
11h	0		DIDL			DIDH										

8.4.1 ALL Register Map

8.4.1.1 Register 0h (offset = 0h) [reset = 0h]

图 8-9. Register 0h

15	14	13	12	11	10	9	8
EXPONENT_CH0				RESULT_MSB_CH0			
R-0h				R-0h			
7	6	5	4	3	2	1	0
RESULT_MSB_CH0							
R-0h							

LEGEND: R/W = Read/Write; W = Write only; -n = value after reset

图 8-10. Register 00 Field Descriptions

Bit	Field	Type	Reset	Description
15-12	EXPONENT_CH0	R	0h	EXPONENT output CH0. Determines the full-scale range of the light measurement for the channel.
11-0	RESULT_MSB_C H0	R	0h	Result register MSB (Most significant bits) CH0. Used to calculate the MANTISSA representing light level within a given EXPONENT or full-scale range

8.4.1.2 Register 1h (offset = 1h) [reset = 0h]

图 8-11. Register 1h

15	14	13	12	11	10	9	8
RESULT_LSB_CH0							
R-0h							
7	6	5	4	3	2	1	0
COUNTER_CH0				CRC_CH0			
R-0h				R-0h			

LEGEND: R/W = Read/Write; W = Write only; -n = value after reset

图 8-12. Register 01 Field Descriptions

Bit	Field	Type	Reset	Description
15-8	RESULT_LSB_C H0	R	0h	Result register LSB(Least significant bits) CH0. Used to calculate MANTISSA representing light level within a given EXPONENT or full-scale range
7-4	COUNTER_CH0	R	0h	Sample counter CH0. Rolling counter which increments for every conversion
3-0	CRC_CH0	R	0h	CRC bits CH0. $R[19:0] = (\text{RESULT_MSB_CH0}[11:0] \ll 8) + \text{RESULT_LSB_C}$ $\text{H0}[7:0]$ $X[0] = \text{XOR}(\text{EXPONENT_CH0}[3:0], R[19:0], \text{CRC_CH0}[3:0])$ XOR of all bits $X[1] = \text{XOR}(\text{CRC_CH0}[1], \text{CRC_CH0}[3], R[1], R[3], R[5], R[7],$ $R[9], R[11], R[13], R[15], R[17], R[19], E[1], E[3])$ $X[2] = \text{XOR}(\text{CRC_CH0}[3], R[3], R[7], R[11], R[15], R[19], E[3])$ $X[3] = \text{XOR}(R[3], R[11], R[19])$

8.4.1.3 Register 2h (offset = 2h) [reset = 0h]

图 8-13. Register 2h

15	14	13	12	11	10	9	8
----	----	----	----	----	----	---	---

图 8-13. Register 2h (continued)

EXPONENT_CH1				RESULT_MSB_CH1			
R-0h				R-0h			
7	6	5	4	3	2	1	0
RESULT_MSB_CH1							
R-0h							

LEGEND: R/W = Read/Write; W = Write only; -n = value after reset

图 8-14. Register 02 Field Descriptions

Bit	Field	Type	Reset	Description
15-12	EXPONENT_CH1	R	0h	EXPONENT output CH1. Determines the full-scale range of the light measurement for the channel.
11-0	RESULT_MSB_C H1	R	0h	Result register MSB (Most significant bits) CH1. Used to calculate the MANTISSA representing light level within a given EXPONENT or full-scale range

8.4.1.4 Register 3h (offset = 3h) [reset = 0h]

图 8-15. Register 3h

15	14	13	12	11	10	9	8
RESULT_LSB_CH1							
R-0h							
7	6	5	4	3	2	1	0
COUNTER_CH1				CRC_CH1			
R-0h				R-0h			

LEGEND: R/W = Read/Write; W = Write only; -n = value after reset

图 8-16. Register 03 Field Descriptions

Bit	Field	Type	Reset	Description
15-8	RESULT_LSB_C H1	R	0h	Result register LSB(Least significant bits) CH1. Used to calculate MANTISSA representing light level within a given EXPONENT or full-scale range
7-4	COUNTER_CH1	R	0h	Sample counter CH1. Rolling counter which increments for every conversion
3-0	CRC_CH1	R	0h	CRC bits CH1. $R[19:0] = (\text{RESULT_MSB_CH1}[11:0] \ll 8) + \text{RESULT_LSB_CH1}[7:0]$ $X[0] = \text{XOR}(\text{EXPONENT_CH1}[3:0], R[19:0], \text{CRC_CH1}[3:0])$ XOR of all bits $X[1] = \text{XOR}(\text{CRC_CH1}[1], \text{CRC_CH1}[3], R[1], R[3], R[5], R[7], R[9], R[11], R[13], R[15], R[17], R[19], E[1], E[3])$ $X[2] = \text{XOR}(\text{CRC_CH1}[3], R[3], R[7], R[11], R[15], R[19], E[3])$ $X[3] = \text{XOR}(R[3], R[11], R[19])$

8.4.1.5 Register 4h (offset = 4h) [reset = 0h]

图 8-17. Register 4h

15	14	13	12	11	10	9	8
EXPONENT_CH2				RESULT_MSB_CH2			
R-0h				R-0h			
7	6	5	4	3	2	1	0

图 8-17. Register 4h (continued)

RESULT_MSB_CH2
R-0h

LEGEND: R/W = Read/Write; W = Write only; -n = value after reset

图 8-18. Register 04 Field Descriptions

Bit	Field	Type	Reset	Description
15-12	EXPONENT_CH2	R	0h	EXPONENT output CH2. Determines the full-scale range of the light measurement for the channel.
11-0	RESULT_MSB_C H2	R	0h	Result register MSB (Most significant bits) CH2. Used to calculate the MANTISSA representing light level within a given EXPONENT or full-scale range

8.4.1.6 Register 5h (offset = 5h) [reset = 0h]

图 8-19. Register 5h

15	14	13	12	11	10	9	8
RESULT_LSB_CH2							
R-0h							
7	6	5	4	3	2	1	0
COUNTER_CH2				CRC_CH2			
R-0h				R-0h			

LEGEND: R/W = Read/Write; W = Write only; -n = value after reset

图 8-20. Register 05 Field Descriptions

Bit	Field	Type	Reset	Description
15-8	RESULT_LSB_C H2	R	0h	Result register LSB(Least significant bits) CH2. Used to calculate MANTISSA representing light level within a given EXPONENT or full-scale range
7-4	COUNTER_CH2	R	0h	Sample counter CH2. Rolling counter which increments for every conversion
3-0	CRC_CH2	R	0h	CRC bits CH2. $R[19:0] = (\text{RESULT_MSB_CH2}[11:0] \ll 8) + \text{RESULT_LSB_C_H2}[7:0]$ XOR of all bits $X[0] = \text{XOR}(\text{EXPONENT_CH2}[3:0], R[19:0], \text{CRC_CH2}[3:0])$ $X[1] = \text{XOR}(\text{CRC_CH2}[1], \text{CRC_CH2}[3], R[1], R[3], R[5], R[7], R[9], R[11], R[13], R[15], R[17], R[19], E[1], E[3])$ $X[2] = \text{XOR}(\text{CRC_CH2}[3], R[3], R[7], R[11], R[15], R[19], E[3])$ $X[3] = \text{XOR}(R[3], R[11], R[19])$

8.4.1.7 Register 6h (offset = 6h) [reset = 0h]

图 8-21. Register 6h

15	14	13	12	11	10	9	8
EXPONENT_CH3				RESULT_MSB_CH3			
R-0h				R-0h			
7	6	5	4	3	2	1	0
RESULT_MSB_CH3							
R-0h							

LEGEND: R/W = Read/Write; W = Write only; -n = value after reset

图 8-22. Register 06 Field Descriptions

Bit	Field	Type	Reset	Description
15-12	EXPONENT_CH3	R	0h	EXPONENT output CH3. Determines the full-scale range of the light measurement for the channel.
11-0	RESULT_MSB_C H3	R	0h	Result register MSB (Most significant bits) CH3. Used to calculate the MANTISSA representing light level within a given EXPONENT or full-scale range

8.4.1.8 Register 7h (offset = 7h) [reset = 0h]

图 8-23. Register 7h

15	14	13	12	11	10	9	8
RESULT_LSB_CH3							
R-0h							
7	6	5	4	3	2	1	0
COUNTER_CH3				CRC_CH3			
R-0h				R-0h			

LEGEND: R/W = Read/Write; W = Write only; -n = value after reset

图 8-24. Register 07 Field Descriptions

Bit	Field	Type	Reset	Description
15-8	RESULT_LSB_C H3	R	0h	Result register LSB(Least significant bits) CH3. Used to calculate MANTISSA representing light level within a given EXPONENT or full-scale range
7-4	COUNTER_CH3	R	0h	Sample counter CH3. Rolling counter which increments for every conversion
3-0	CRC_CH3	R	0h	CRC bits CH3. $R[19:0] = (\text{RESULT_MSB_CH3}[11:0] \ll 8) + \text{RESULT_LSB_C}$ $\text{H3}[7:0]$ $X[0] = \text{XOR}(\text{EXPONENT_CH3}[3:0], R[19:0], \text{CRC_CH3}[3:0])$ XOR of all bits $X[1] = \text{XOR}(\text{CRC_CH3}[1], \text{CRC_CH3}[3], R[1], R[3], R[5], R[7],$ $R[9], R[11], R[13], R[15], R[17], R[19], E[1], E[3])$ $X[2] = \text{XOR}(\text{CRC_CH3}[3], R[3], R[7], R[11], R[15], R[19], E[3])$ $X[3] = \text{XOR}(R[3], R[11], R[19])$

8.4.1.9 Register 8h (offset = 8h) [reset = 0h]

图 8-25. Register 8h

15	14	13	12	11	10	9	8
THRESHOLD_L_EXPONENT				THRESHOLD_L_RESULT			
R/W-0h				R/W-0h			
7	6	5	4	3	2	1	0
THRESHOLD_L_RESULT							
R/W-0h							

LEGEND: R/W = Read/Write; W = Write only; -n = value after reset

图 8-26. Register 08 Field Descriptions

Bit	Field	Type	Reset	Description
15-12	THRESHOLD_L_EXPONENT	R/W	0h	Threshold low register exponent
11-0	THRESHOLD_L_RESULT	R/W	0h	Threshold low register result

8.4.1.10 Register 9h (offset = 9h) [reset = BFFFh]

图 8-27. Register 9h

15	14	13	12	11	10	9	8
THRESHOLD_H_EXPONENT				THRESHOLD_H_RESULT			
R/W-Bh				R/W-Fh			
7	6	5	4	3	2	1	0
THRESHOLD_H_RESULT							
R/W-FFh							

LEGEND: R/W = Read/Write; W = Write only; -n = value after reset

图 8-28. Register 09 Field Descriptions

Bit	Field	Type	Reset	Description
15-12	THRESHOLD_H_EXPONENT	R/W	Bh	Threshold high register exponent
11-0	THRESHOLD_H_RESULT	R/W	FFFh	Threshold high register result

8.4.1.11 Register Ah (offset = Ah) [reset = 3208h]

图 8-29. Register Ah

15	14	13	12	11	10	9	8
QWAKE	0	RANGE				CONVERSION_TIME	
R/W-0h	W-0h	R/W-Ch				R/W-2h	
7	6	5	4	3	2	1	0
CONVERSION_TIME		OPERATING_MODE		LATCH	INT_POL	FAULT_COUNT	
R/W-0h		R/W-0h		R/W-1h	R/W-0h	R/W-0h	

LEGEND: R/W = Read/Write; W = Write only; -n = value after reset

图 8-30. Register 0A Field Descriptions

Bit	Field	Type	Reset	Description
15-15	QWAKE	R/W	0h	Quick Wake-up from Standby in one shot mode by not powering down all circuits. Applicable only in One-shot mode and helps get out of standby mode faster with penalty in power consumption compared to full standby mode.
14-14	0	W	0h	Must read or write 0

图 8-30. Register 0A Field Descriptions (continued)

Bit	Field	Type	Reset	Description
13-10	RANGE	R/W	Ch	Controls the full-scale light level range of the device. The format of this register is same as the EXPONENT register for all values from 0 to 6. 0 : 2.2klux 1 : 4.5kux 2 : 9klux 3 : 18klux 4 : 36klux 5 : 72klux 6 : 144klux 12 : Auto-Range
9-6	CONVERSION_TIME	R/W	8h	Controls the device conversion time per channel 0 : 600 us 1 : 1 ms 2 : 1.8 ms 3 : 3.4 ms 4 : 6.5 ms 5 : 12.7 ms 6 : 25 ms 7 : 50 ms 8 : 100 ms 9 : 200 ms 10 : 400 ms 11 : 800 ms
5-4	OPERATING_MODE	R/W	0h	Controls device mode of operation 0 : Power-down 1 : Forced auto-range OneShot 2 : OneShot 3 : Continuous
3-3	LATCH	R/W	1h	Controls the functionality of the interrupt reporting mechanisms for INT pin for the threshold detection logic.
2-2	INT_POL	R/W	0h	Controls the polarity or active state of the INT pin. 0 : Active Low 1 : Active High
1-0	FAULT_COUNT	R/W	0h	Fault count register instructs the device as to how many consecutive fault events are required to trigger the threshold mechanisms: the flag high (FLAG_H) and the flag low (FLAG_L) registers. 0 : One fault Count 1 : Two Fault Counts 2 : Four Fault Counts 3 : Eight Fault Counts

8.4.1.12 Register Bh (offset = Bh) [reset = 8011h]

图 8-31. Register Bh

15	14	13	12	11	10	9	8
1	0	0	0	0	0	0	0
R/W-1h	R/W-0h	W-0h	W-0h	W-0h	R/W-0h	R/W-0h	R/W-0h
7	6	5	4	3	2	1	0
0	THRESHOLD_CH_SEL		INT_DIR	INT_CFG		0	I2C_BURST
R/W-0h	R/W-0h		R/W-1h	R/W-0h		R/W-0h	R/W-1h

LEGEND: R/W = Read/Write; W = Write only; -n = value after reset

图 8-32. Register 0B Field Descriptions

Bit	Field	Type	Reset	Description
15-7	128	R/W	80h	Must read or write 128

图 8-32. Register 0B Field Descriptions (continued)

Bit	Field	Type	Reset	Description
6-5	THRESHOLD_CH_SEL	R/W	0h	Channel select for threshold logic 0 : CH0 Selected 1 : CH1 Selected 2 : CH2 Selected 3 : CH3 Selected
4-4	INT_DIR	R/W	1h	Determines the direction of the INT pin. 0 : Input 1 : Output
3-2	INT_CFG	R/W	0h	Controls the output interrupt mechanism after end of conversion 0 : SMBUS Alert 1 : INT Pin data ready for next channel 3 : INT Pin data ready for all channels
1-1	0	R/W	0h	Must read or write 0
0-0	I2C_BURST	R/W	1h	When set enables I2C burst mode minimizing I2C read cycles by auto incrementing read register point by 1 after every register read

8.4.1.13 Register Ch (offset = Ch) [reset = 0h]

图 8-33. Register Ch

15	14	13	12	11	10	9	8
0	0	0	0	0	0	0	0
R/W-0h	R/W-0h	R/W-0h	R/W-0h	R/W-0h	R/W-0h	R/W-0h	R/W-0h
7	6	5	4	3	2	1	0
0	0	0	0	OVERLOAD_FLAG	CONVERSION_READY_FLAG	FLAG_H	FLAG_L
R/W-0h	R/W-0h	R/W-0h	R/W-0h	R-0h	R-0h	R-0h	R-0h

LEGEND: R/W = Read/Write; W = Write only; -n = value after reset

图 8-34. Register 0C Field Descriptions

Bit	Field	Type	Reset	Description
15-4	0	R/W	0h	Must read or write 0
3-3	OVERLOAD_FLAG	R	0h	Indicates when an overflow condition occurs in the data conversion process, typically because the light illuminating the device exceeds the full-scale range.
2-2	CONVERSION_READY_FLAG	R	0h	Conversion ready flag indicates when a conversion completes. The flag is set to 1 at the end of a conversion and is cleared (set to 0) when register address 0xA is either read or written with any non-zero value 0 : Conversion in progress 1 : Conversion is complete
1-1	FLAG_H	R	0h	Flag high register identifies that the result of a conversion is measurement than a specified level of interest. FLAG_H is set to 1 when the result is larger than the level in the THRESHOLD_H_EXPONENT and THRESHOLD_H_RESULT registers for a consecutive number of measurements defined by the FAULT_COUNT register.

图 8-34. Register 0C Field Descriptions (continued)

Bit	Field	Type	Reset	Description
0-0	FLAG_L	R	0h	Flag low register identifies that the result of a measurement is smaller than a specified level of interest. FLAG_L is set to 1 when the result is smaller than the level in the THRESHOLD_L_EXPONENT and THRESHOLD_L_RESULT registers for a consecutive number of measurements defined by the FAULT_COUNT register.

8.4.1.14 Register 11h (offset = 11h) [reset = 820h]

图 8-35. Register 11h

15	14	13	12	11	10	9	8
0	0	DIDL		DIDH			
R/W-0h	R/W-0h	R-0h		R-8h			
7	6	5	4	3	2	1	0
DIDH							
R-21h							

LEGEND: R/W = Read/Write; W = Write only; -n = value after reset

图 8-36. Register 11 Field Descriptions

Bit	Field	Type	Reset	Description
15-14	0	R/W	0h	Must read or write 0
13-12	DIDL	R	8h	Device ID L
11-0	DIDH	R	21h	Device ID H

9 Application and Implementation

备注

以下应用部分中的信息不属于 TI 器件规格的范围，TI 不担保其准确性和完整性。TI 的客户应负责确定器件是否适用于其应用。客户应验证并测试其设计，以确保系统功能。

9.1 Application Information

Color sensors are used in a wide variety of applications that require precise measurement of light as perceived by human eye, since the color sensors have a specialized filter that mimic human eye. The following sections shows crucial information about integrating OPT4048 in applications.

There are two categories of interface to the OPT4048: electrical and optical.

9.2 Typical Application

9.2.1 Electrical Interface

The electrical interface is quite simple, as illustrated in 图 9-1 below. Connect the OPT4048 I²C SDA and SCL pins to the same pins of an applications processor, micro controller, or other digital processor. If that digital processor requires an interrupt resulting from an event of interest from the OPT4048, then connect the INT pin to either an interrupt or general-purpose I/O pin of the processor. There are multiple uses for this INT pin, including triggering a measurement on one-shot mode, signaling the system to wake up from low-power mode, processing other tasks while waiting for an ambient light event of interest, or alerting the processor that a sample is ready to be read. Connect pullup resistors between a power supply appropriate for digital communication and the SDA and SCL pins (because the pins have open-drain output structures). If the INT pin is used, connect a pullup resistor to the INT pin. A typical value for these pullup resistors is 10 k Ω . The resistor choice can be optimized in conjunction to the bus capacitance to balance the system speed, power, noise immunity, and other requirements.



图 9-1. Typical Application Schematic

The power supply and grounding considerations are discussed in the 节 9.4.

Although spike suppression is integrated in the SDA and SCL pin circuits, use proper layout practices to minimize the amount of coupling into the communication lines. One possible introduction of noise occurs from capacitively coupling signal edges between the two communication lines themselves. Another possible noise introduction comes from other switching noise sources present in the system, especially for long communication

lines. In noisy environments, shield communication lines to reduce the possibility of unintended noise coupling into the digital I/O lines that can be incorrectly interpreted.

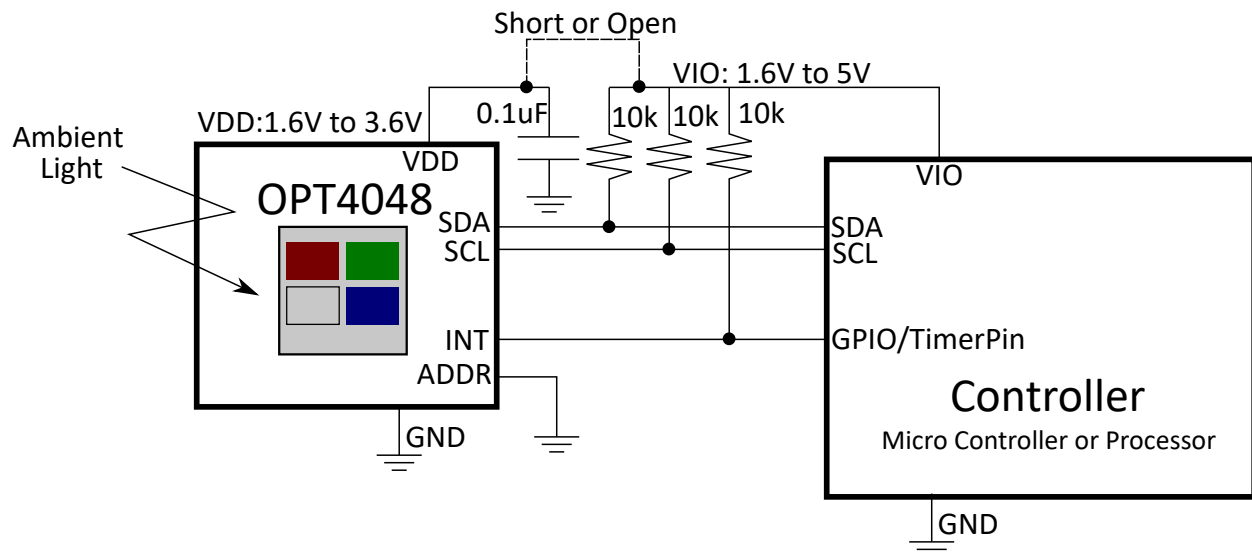
9.2.2 Design Requirements

9.2.2.1 Optical Interface



图 9-2. Sensor Position

Any physical component that affects the light which illuminates the sensing area of a light sensor also affects the performance of that light sensor. Therefore, for the best performance, make sure to understand and control the effect of these components. Design a window width and height to permit light from a sufficient field of view to illuminate the sensor. For best performance, use a field of view of at least $\pm 35^\circ$, or preferably $\pm 45^\circ$ or more. Understanding and designing the field of view is discussed further in application report [OPT3001: Ambient Light Sensor Application Guide \(SBEA002\)](#).

9.2.3 Detailed Design Procedure

9.2.3.1 Optomechanical Design

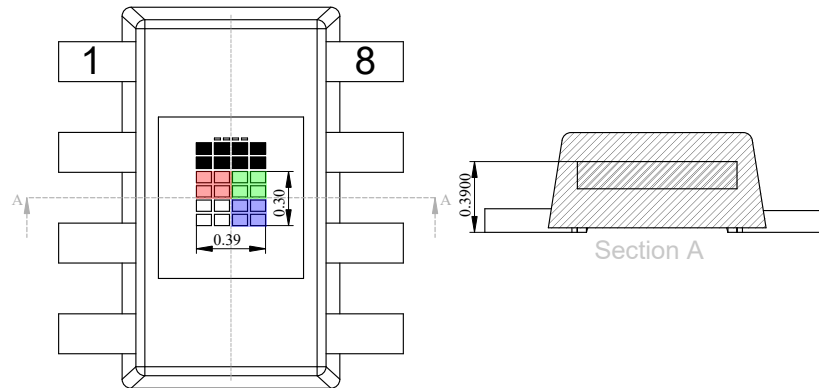
After completing the electrical design, the next task is the optomechanical design. Window sizing and placement is discussed in more rigorous detail in [OPT3001: Ambient Light Sensor Application Guide](#).

9.2.4 Application Curves

Matrix values for Color determination

ADC measurements from OPT4048 channels can be used to determine the intensity (lux) and the color (CIE X,Y coordinates) as per specified in 节 8.3.4.5. Here is an example of such measurements performed an RGB LED source TI LP5036EVM. The intensity of the Red, Green and Blue LEDs were varied independently and the corresponding color coordinates detected by OPT4048 (CIE_x,CIE_y) are plotted on the CIE XY and CIE UV color space.



图 9-3. CIE XY and CIE UV space plots of color coordinates

Value of **matrix** used for this calculation is as shown below

$$\begin{bmatrix} 2.34892992e-04 & -1.89652390e-05 & 1.20811684e-05 & 0 \\ 4.07467441e-05 & 1.98958202e-04 & -1.58848115e-05 & 2.15e-3 \\ 9.28619404e-05 & -1.69739553e-05 & 6.74021520e-04 & 0 \\ 0 & 0 & 0 & 0 \end{bmatrix} \quad (16)$$

Correlated Color Temperature

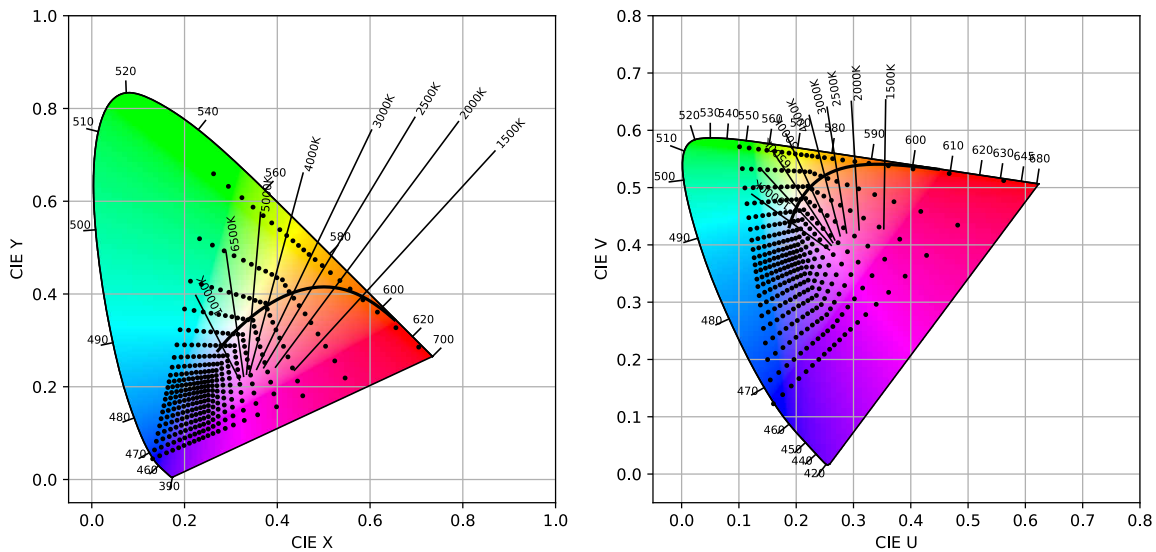
The CIE XY and CIE UV color spaces shown in 图 9-3 and 图 9-4 has been annotated with the ideal black body curve and intersecting iso-thermal lines. The ideal black body curve represents the color perceived by human eye in CIE YX and CIE UV spaces when an ideal black body of certain Kelvins emit radiation. The intersecting lines with various kelvin markings are iso-thermal lines which represent the same color temperature and is commonly referred to as Correlated Color Temperature (CCT). CCT is a representation of how warm or cool a color source is which is a common terminology used in classifying light bulbs. CCT is often valid only around the ideal black body curve and does not make sense when there is too much deviation. Any color coordinate close to the ideal black body curve can be represented as having a particular CCT by using the formula below:

$$CCT = 437n^3 + 3601n^2 + 6861n + 5517 \quad (17)$$

where n is defined as

$$n = \frac{CIE_x - 0.3320}{0.1858 - CIE_y} \quad (18)$$

These are highly non-linear functions and the estimation of the CCT is very sensitive to the CIE X and CIE Y coordinates. Small errors due to non-ideality in the system can cause an amplified error in CCT estimation.

Set of off the shelf lamp sources were taken and the CCT values measured by OPT4048 is shown below.



图 9-4. CIE XY and CIE UV Space Plots of Color Coordinates

The CIE color space plots have been zoomed-in to see the points more clearly. The annotation in the plot specify the color temperature of the lamps as specified by the manufacturer. While the lamp manufacturers approximate the CCT in Kelvins to nearest 1000 s, 500 s or 100 s, OPT4048 estimates the CCT high resolution using the equations specified above.

Color accuracy and the CCT accuracy can be further optimized based on the cavity design, cover glass and target application. More information is available at [OPT4048](#).

9.3 Do's and Don'ts

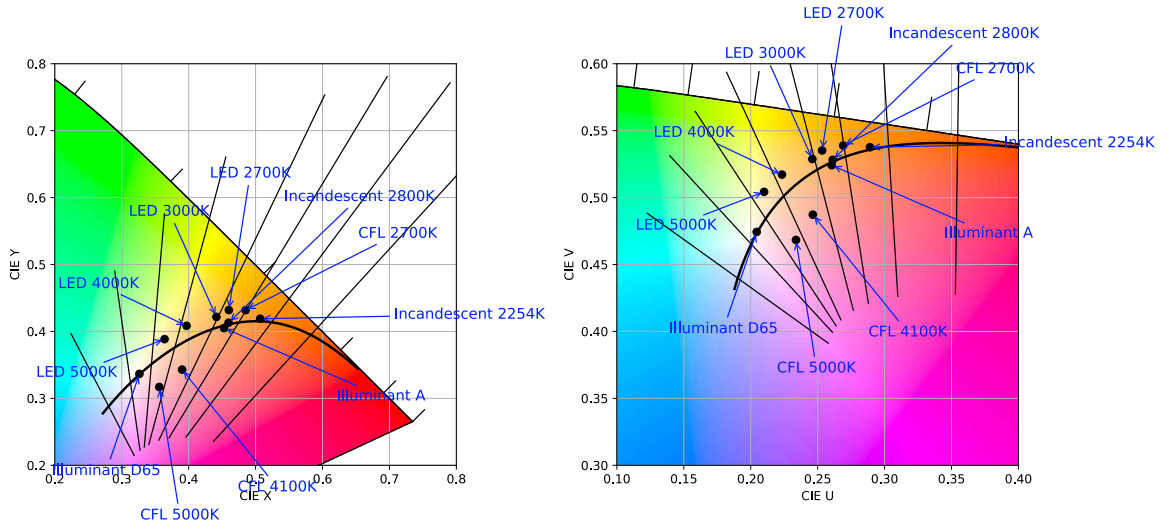
As with any optical product, take special care when handling the OPT4048. The device is a piece of active silicon, without the mechanical protection of an epoxy-like package or other reinforcement. This design allows the device to be as thin as possible. Take extra care to handle the device gently to not crack or break the device. Use a properly-sized vacuum manipulation tool to handle the device.

The optical surface of the device must be kept clean for best performance, both when prototyping with the device, and during mass production manufacturing procedures. Keep the optical surface clean of fingerprints, dust, and other optical-inhibiting contaminants.

If the optical surface of the device requires cleaning, use a few gentle brushes with a soft swab of deionized water or isopropyl alcohol. Avoid potentially abrasive cleaning and manipulating tools and excessive force that can scratch the optical surface.

If the OPT4048 performs less than optimally, then inspect the optical surface for dirt, scratches, or other optical artifacts.

9.4 Power Supply Recommendations

Although the OPT4048 has low sensitivity to power-supply noise, good practices are always recommended. For best performance, the OPT4048 VDD pin must have a stable, low-noise power supply with a 100-nF bypass capacitor close to the device and solid grounding. There are many options for powering the OPT4048 because of the device low current consumption levels.

9.5 Layout

9.5.1 Layout Guidelines

The PCB layout design for the OPT4048 requires a couple of considerations. Bypass the power supply with a capacitor placed close to the device. Note that optically reflective surfaces of components also affect the performance of the design. The three-dimensional geometry of all components and structures around the sensor must be taken into consideration to prevent unexpected results from secondary optical reflections. Placing capacitors and components at a distance of at least twice the height of the component is usually sufficient. The best optical layout is to place all close components on the opposite side of the PCB from the device. However, this approach is not practical for the constraints of every design.

An example PCB layout with the OPT4048 is shown in [图 9-5](#).

9.5.2 Layout Example



图 9-5. Example PCB Layout with the OPT4048 SOT-5X3 (8) Package

9.5.3 Soldering and Handling Recommendations

Soldering temperature profile and guidelines are published in future revisions of this document.

As with most optical devices, handle the OPT4048 with special care to ensure optical surfaces stay clean and free from damage. See [节 9.3](#) for more detailed recommendations. For best optical performance, solder flux and any other possible debris must be cleaned after soldering processes.

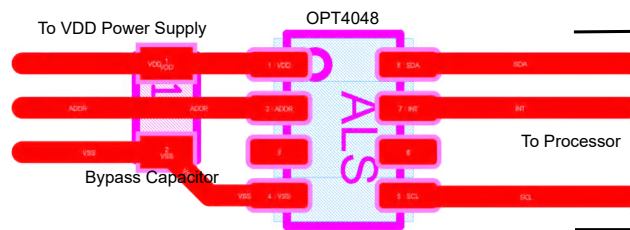

备注

The bottom side of the device features an angled feature to denote the PIN 1

图 9-6. Identification Feature for PIN 1



图 9-7. Identification Features for PIN 1 on Package

10 Device and Documentation Support

10.1 Documentation Support

10.1.1 Related Documentation

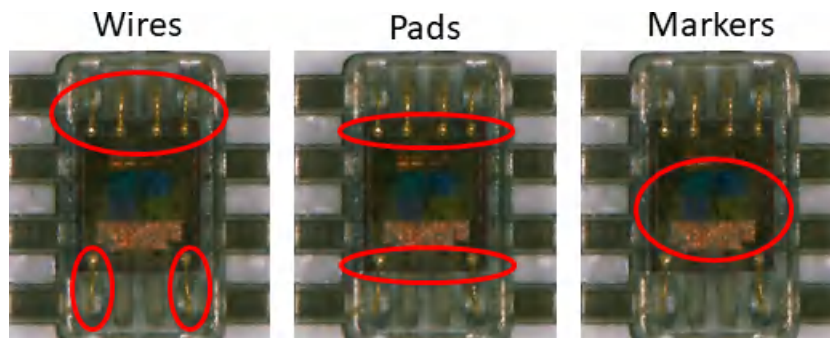
- [OPT4048EVM User's Guide](#)
- [OPT3001: Ambient Light Sensor Application Guide](#)

10.2 接收文档更新通知

要接收文档更新通知，请导航至 [ti.com](https://www.ti.com) 上的器件产品文件夹。点击 [订阅更新](#) 进行注册，即可每周接收产品信息更改摘要。有关更改的详细信息，请查看任何已修订文档中包含的修订历史记录。

10.3 支持资源

[TI E2E™ 支持论坛](#) 是工程师的重要参考资料，可直接从专家获得快速、经过验证的解答和设计帮助。搜索现有解答或提出自己的问题可获得所需的快速设计帮助。

链接的内容由各个贡献者“按原样”提供。这些内容并不构成 TI 技术规范，并且不一定反映 TI 的观点；请参阅 TI 的《[使用条款](#)》。

10.4 Trademarks

TI E2E™ is a trademark of Texas Instruments.

所有商标均为其各自所有者的财产。

10.5 Electrostatic Discharge Caution



This integrated circuit can be damaged by ESD. Texas Instruments recommends that all integrated circuits be handled with appropriate precautions. Failure to observe proper handling and installation procedures can cause damage.

ESD damage can range from subtle performance degradation to complete device failure. Precision integrated circuits may be more susceptible to damage because very small parametric changes could cause the device not to meet its published specifications.

10.6 术语表

[TI 术语表](#) 本术语表列出并解释了术语、首字母缩略词和定义。

11 Mechanical, Packaging, and Orderable Information

The following pages include mechanical, packaging, and orderable information. This information is the most current data available for the designated devices. This data is subject to change without notice and revision of this document. For browser-based versions of this data sheet, refer to the left-hand navigation.

PACKAGING INFORMATION

Orderable Device	Status (1)	Package Type	Package Drawing	Pins	Package Qty	Eco Plan (2)	Lead finish/ Ball material (6)	MSL Peak Temp (3)	Op Temp (°C)	Device Marking (4/5)	Samples
OPT4048DTSR	ACTIVE	SOT-5X3	DTS	8	3000	RoHS & Green	NIPDAU	Level-2-260C-1 YEAR	-40 to 85	4048	Samples
OPT4048DTST	ACTIVE	SOT-5X3	DTS	8	250	RoHS & Green	NIPDAU	Level-2-260C-1 YEAR	-40 to 85	4048	Samples

(1) The marketing status values are defined as follows:

ACTIVE: Product device recommended for new designs.

LIFEBUY: TI has announced that the device will be discontinued, and a lifetime-buy period is in effect.

NRND: Not recommended for new designs. Device is in production to support existing customers, but TI does not recommend using this part in a new design.

PREVIEW: Device has been announced but is not in production. Samples may or may not be available.

OBSELETE: TI has discontinued the production of the device.

(2) **RoHS:** TI defines "RoHS" to mean semiconductor products that are compliant with the current EU RoHS requirements for all 10 RoHS substances, including the requirement that RoHS substance do not exceed 0.1% by weight in homogeneous materials. Where designed to be soldered at high temperatures, "RoHS" products are suitable for use in specified lead-free processes. TI may reference these types of products as "Pb-Free".

RoHS Exempt: TI defines "RoHS Exempt" to mean products that contain lead but are compliant with EU RoHS pursuant to a specific EU RoHS exemption.

Green: TI defines "Green" to mean the content of Chlorine (Cl) and Bromine (Br) based flame retardants meet JS709B low halogen requirements of <=1000ppm threshold. Antimony trioxide based flame retardants must also meet the <=1000ppm threshold requirement.

(3) MSL, Peak Temp. - The Moisture Sensitivity Level rating according to the JEDEC industry standard classifications, and peak solder temperature.

(4) There may be additional marking, which relates to the logo, the lot trace code information, or the environmental category on the device.

(5) Multiple Device Markings will be inside parentheses. Only one Device Marking contained in parentheses and separated by a "~" will appear on a device. If a line is indented then it is a continuation of the previous line and the two combined represent the entire Device Marking for that device.

(6) Lead finish/Ball material - Orderable Devices may have multiple material finish options. Finish options are separated by a vertical ruled line. Lead finish/Ball material values may wrap to two lines if the finish value exceeds the maximum column width.

Important Information and Disclaimer:The information provided on this page represents TI's knowledge and belief as of the date that it is provided. TI bases its knowledge and belief on information provided by third parties, and makes no representation or warranty as to the accuracy of such information. Efforts are underway to better integrate information from third parties. TI has taken and continues to take reasonable steps to provide representative and accurate information but may not have conducted destructive testing or chemical analysis on incoming materials and chemicals. TI and TI suppliers consider certain information to be proprietary, and thus CAS numbers and other limited information may not be available for release.

In no event shall TI's liability arising out of such information exceed the total purchase price of the TI part(s) at issue in this document sold by TI to Customer on an annual basis.

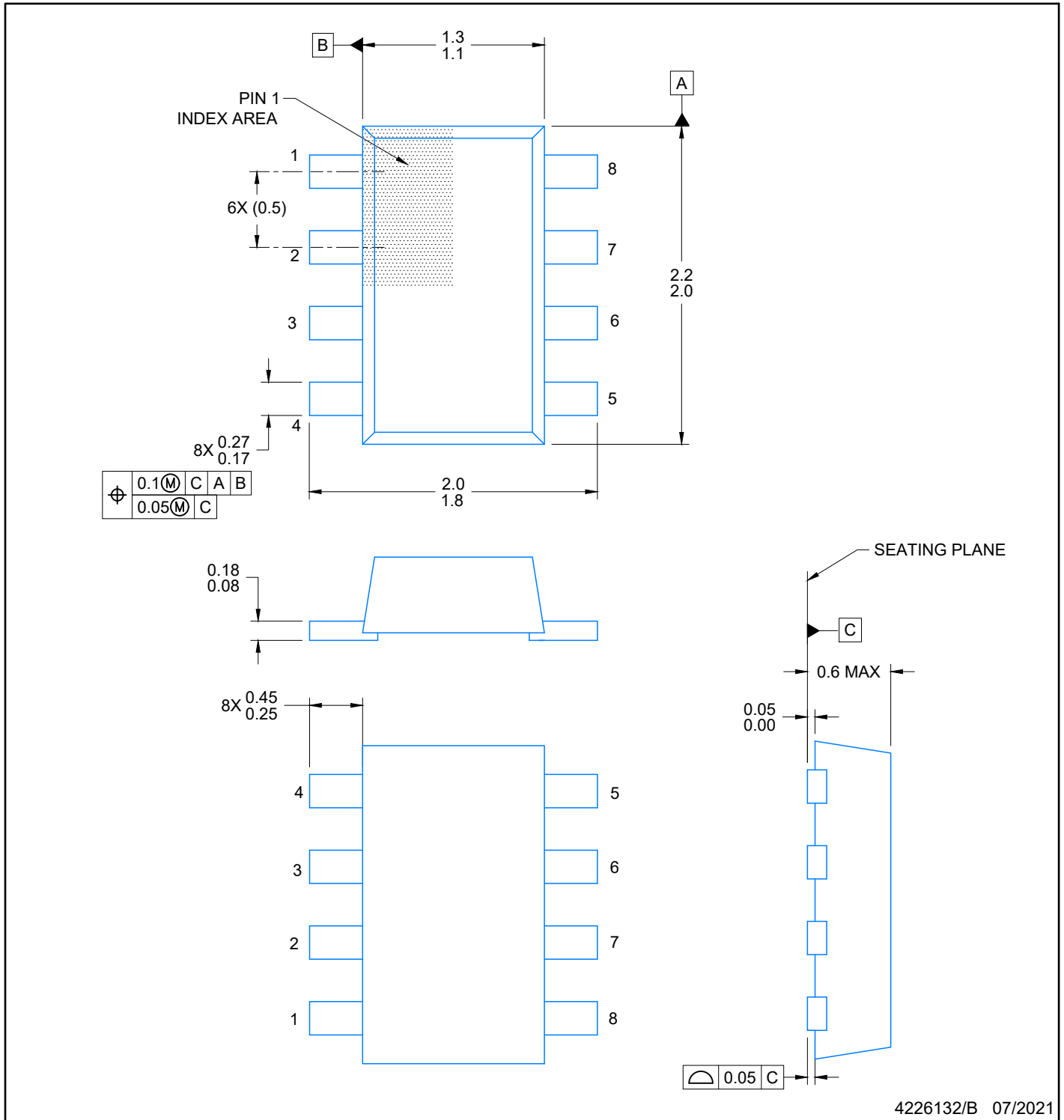

NOTES:

1. All linear dimensions are in millimeters. Any dimensions in parenthesis are for reference only. Dimensioning and tolerancing per ASME Y14.5M.
2. This drawing is subject to change without notice.
3. Body dimensions do not include mold flash, protrusions or gate burrs. Mold flash, interlead flash, protrusions or gate burrs shall not exceed 0.15 per end or side

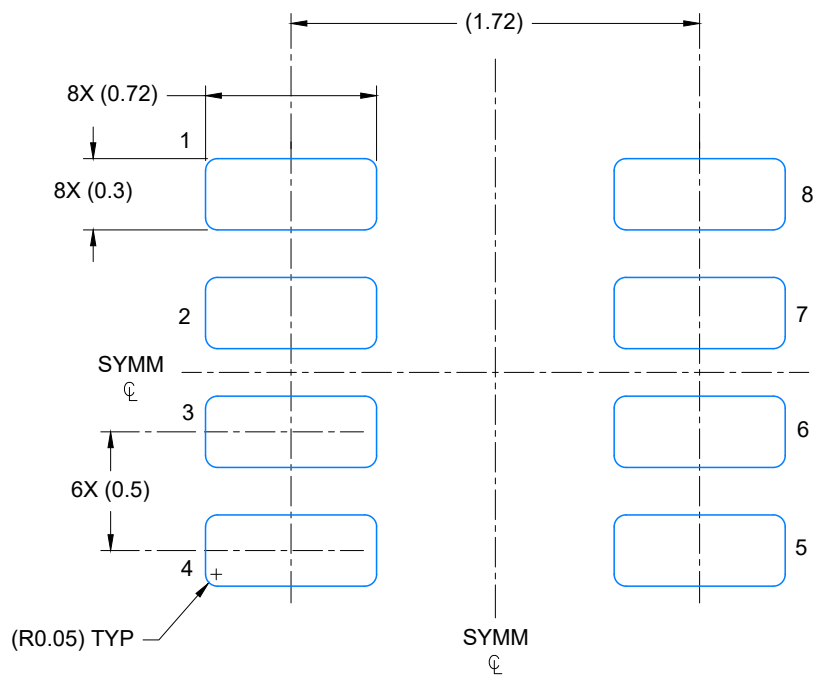

LAND PATTERN EXAMPLE
EXPOSED METAL SHOWN
SCALE: 30X

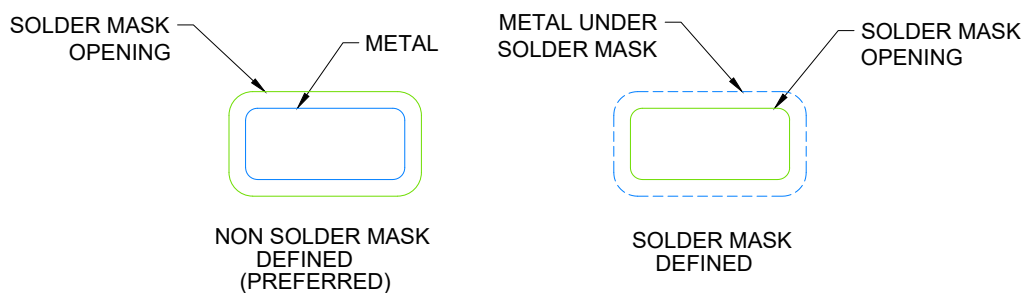

SOLDER MASK DETAILS

4226132/B 07/2021

NOTES: (continued)

4. Publication IPC-7351 may have alternate designs.
5. Solder mask tolerances between and around signal pads can vary based on board fabrication site.

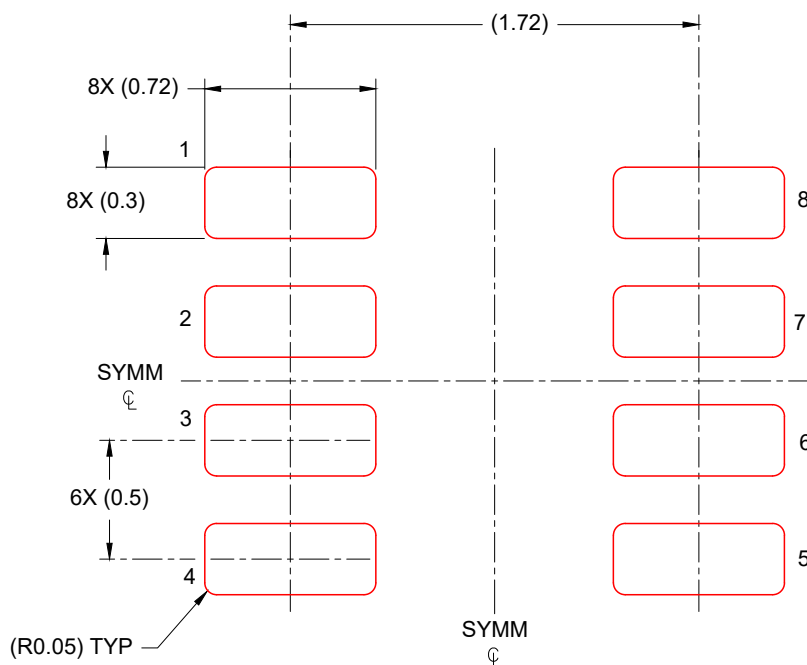

SOLDER PASTE EXAMPLE
 BASED ON 0.125 mm THICK STENCIL
 SCALE: 30X

4226132/B 07/2021

NOTES: (continued)

- 6. Laser cutting apertures with trapezoidal walls and rounded corners may offer better paste release. IPC-7525 may have alternate design recommendations.
- 7. Board assembly site may have different recommendations for stencil design.

重要声明和免责声明

TI“按原样”提供技术和可靠性数据（包括数据表）、设计资源（包括参考设计）、应用或其他设计建议、网络工具、安全信息和其他资源，不保证没有瑕疵且不做任何明示或暗示的担保，包括但不限于对适销性、某特定用途方面的适用性或不侵犯任何第三方知识产权的暗示担保。

这些资源可供使用 TI 产品进行设计的熟练开发人员使用。您将自行承担以下全部责任：(1) 针对您的应用选择合适的 TI 产品，(2) 设计、验证并测试您的应用，(3) 确保您的应用满足相应标准以及任何其他功能安全、信息安全、监管或其他要求。

这些资源如有变更，恕不另行通知。TI 授权您仅可将这些资源用于研发本资源所述的 TI 产品的应用。严禁对这些资源进行其他复制或展示。您无权使用任何其他 TI 知识产权或任何第三方知识产权。您应全额赔偿因在这些资源的使用中对 TI 及其代表造成的任何索赔、损害、成本、损失和债务，TI 对此概不负责。

TI 提供的产品受 [TI 的销售条款](#) 或 [ti.com](#) 上其他适用条款/TI 产品随附的其他适用条款的约束。TI 提供这些资源并不会扩展或以其他方式更改 TI 针对 TI 产品发布的适用的担保或担保免责声明。

TI 反对并拒绝您可能提出的任何其他或不同的条款。

邮寄地址：Texas Instruments, Post Office Box 655303, Dallas, Texas 75265

Copyright © 2023，德州仪器 (TI) 公司