

INTEGRATED PHOTO FLASH CHARGER AND IGBT DRIVER

FEATURES

- Highly Integrated Solution to Reduce Components
- Integrated Voltage Reference
- Integrated 50-V Power Switch,
- Integrated IGBT Driver
- High Efficiency
- Programmable Peak Current, 0.9 A ~ 1.8 A
- Input Battery Voltage of 1.6 V to 12 V
- Optimized Control Loop for Fast Charge Time
- Output Voltage Feedback From Primary Side
- 16-Pin QFN Package
- Protection
 - MAX On Time
 - MAX Off Time
 - Overcurrent Shutdown to Monitor V_{DS} at the SW pin (OV_{DS})
 - Thermal Disable

APPLICATIONS

- Digital Still Cameras
- Optical Film Cameras
- Mobile Phones With Camera
- PDAs With Camera

DESCRIPTION

This device offers a complete solution for charging a photo flash capacitor from battery input, and subsequently discharging the capacitor to a xenon flash tube. The device has an integrated voltage reference, power switch, IGBT driver, and control logic blocks for charging applications and driving IGBT applications. Compared with discrete solutions, this device reduces the component count, shrinks the solution size, and eases designs for xenon tube applications. Additional advantages are a fast charging time and high efficiency from an optimized PWM control algorithm.

Other provisions of the device includes sensing the output voltage from the primary side, programmable peak current, thermal shutdown, an output pin for charge completion, and input pins for charge enable and flash enable.

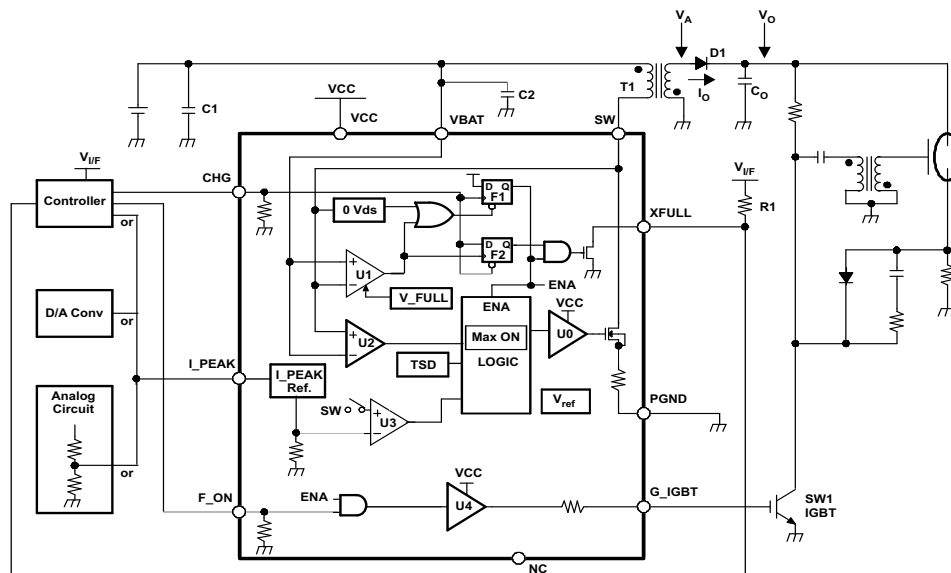

Figure 1. Typical Application Circuit



Please be aware that an important notice concerning availability, standard warranty, and use in critical applications of Texas Instruments semiconductor products and disclaimers thereto appears at the end of this data sheet.

PowerPAD is a trademark of Texas Instruments.



These devices have limited built-in ESD protection. The leads should be shorted together or the device placed in conductive foam during storage or handling to prevent electrostatic damage to the MOS gates.

ORDERING INFORMATION

T_A	PACKAGE MARKING	PACKAGE ⁽¹⁾	PART NUMBER
-35°C to 85°C	BPR	16-pin QFN	TPS65560RGT

(1) For the most current package and ordering information, see the Package Option Addendum at the end of this document, or see the TI Web site at www.ti.com.

ABSOLUTE MAXIMUM RATINGS

over operating free-air temperature range (unless otherwise noted) ⁽¹⁾

			UNIT
V_{SS}	Supply voltage	VCC	-0.6 V to 6 V
		VBAT	-0.6 V to 13 V
$V_{(SW)}$	Switch terminal voltage		-0.6 V to 50 V
$I_{(SW)}$	Switch current between SW and PGND, ISW		3 A
V_I	Input voltage of CHG, I_PEAK, F_ON		-0.3 V to V_{CC}
T_{stg}	Storage temperature		-40°C to 150°C
T_J	Maximum junction temperature		125°C
	ESD rating	HBM (Human Body Model) JEDEC JES22-A114	1 kV

(1) Stresses beyond those listed under "absolute maximum ratings" may cause permanent damage to the device. These are stress ratings only and functional operation of the device at these or any other conditions beyond those indicated under "recommended operating conditions" is not implied. Exposure to absolute-maximum-rated conditions for extended periods may affect device reliability.

RECOMMENDED OPERATING CONDITIONS

		MIN	NOM	MAX	UNIT
V_{SS}	Supply voltage, VCC	2.7		4	V
	Supply voltage, VBAT	1.6		12	V
$V_{(SW)}$	Switch terminal voltage,	-0.3		45	V
$I_{(SW)}$	Switch current between SW and PGND			2	A
	Operating free-air temperature range	-35		85	°C
V_{IH}	High-level digital input voltage at CHG and F_ON	2			V
V_{IL}	Low-level digital input voltage at CHG and F_ON			0.5	V

DISSIPATION RATINGS

PACKAGE	$R_{\theta JA}$ ⁽¹⁾	POWER RATING $T_A < 25^\circ\text{C}$	POWER RATING $T_A = 70^\circ\text{C}$	POWER RATING $T_A = 85^\circ\text{C}$
QFN	47.4 °C/W	2.11 W	1.16 W	844 mW

(1) The thermal resistance, $R_{\theta JA}$, is based on a soldered PowerPAD™ on a 2S2P JEDEC board using thermal vias.

ELECTRICAL CHARACTERISTICS

$T_A = 25^\circ\text{C}$, $V_{BAT} = 4.2\text{ V}$, $V_{CC} = 3\text{ V}$, $V_{(SW)} = 4.2\text{ V}$ (unless otherwise noted)

PARAMETER	TEST CONDITIONS	MIN	TYP	MAX	UNIT	
$R_{(ONL)}$	ON resistance of XFULL		1.5	3	$k\Omega$	
$V_{(PKH)}^{(1)}$	Upper threshold voltage of I_{PEAK}	$V_{CC} = 3\text{ V}$	2.4		V	
$V_{(PKL)}^{(1)}$	Lower threshold voltage of I_{PEAK}	$V_{CC} = 3\text{ V}$		0.6	V	
I_{CC1}	Supply current from V_{BAT}	CHG = H, $V_{(SW)} = 0\text{ V}$ (free run by t_{MAX})	17	50	μA	
I_{CC2}	Supply current from V_{CC}	CHG = H, $V_{(SW)} = 0\text{ V}$ (free run by t_{MAX})	1.3	3	mA	
I_{CC3}	Supply current from V_{CC} and V_{BAT}	CHG = L		1	μA	
I_{lkg1}	Leakage current of SW terminal			2	μA	
I_{lkg2}	Leakage current of XFULL terminal	$V_{(XFULL)} = 5\text{ V}$		1	μA	
$I_{(sink)}$	Sink current at I_{PEAK}	$V_{(L_PEAK)} = 3\text{ V}$, CHG: High		2	μA	
		$V_{(L_PEAK)} = 3\text{ V}$, CHG: Low		0.1		
$R_{(ONSW)}$	SW ON resistance between SW and PGND	$I_{(SW)} = 1\text{ A}$, $V_{CC} = 3\text{ V}$	0.4	0.9	Ω	
$R_{(IGBT1)}$	G_IGBT pullup resistance	$V_{(G_IGBT)} = 0\text{ V}$, $V_{CC} = 3\text{ V}$	8	12	19.4	Ω
$R_{(IGBT2)}$	G_IGBT pulldown resistance	$V_{(G_IGBT)} = 3\text{ V}$, $V_{CC} = 3\text{ V}$	36	53	70	Ω
$I_{(PEAK1)}$	Upper peak of $I_{(SW)}$	$V_{(L_IPEAK)} = 3\text{ V}$	1.58	1.68	1.78	A
$I_{(PEAK2)}$	Lower peak of $I_{(SW)}$	$V_{(L_IPEAK)} = 0\text{ V}$	0.7	0.8	0.9	A
$V_{(FULL)}$	Charge completion detect voltage at $V_{(SW)}$	$V_{BAT} = 1.6\text{ V}$, $V_{CC} = 3\text{ V}$	28	28.7	29.4	V
		$V_{CC} = 3\text{ V}$	28.6	29	29.4	
$V_{(ZERO)}$	Zero current detection at $V_{(SW)}$		1	20	60	mV
$T_{(SD)}^{(1)}$	Thermal shutdown temperature		150	160	170	$^\circ\text{C}$
	Over V_{DS} detection at $V_{(SW)}$		0.95	1.2	1.45	V
t_{MIN}	MAX OFF time		25	50	80	μs
t_{MAX}	MAX ON time		50	100	160	μs
$R_{(INPD)}$	Pulldown resistance of CHG, F_ON	$V_{CHG} = V_{(F_ON)} = 4.2\text{ V}$		100		$k\Omega$

(1) Specified by design.

SWITCHING CHARACTERISTICS

$T_A = 25^\circ\text{C}$, $V_{BAT} = 4.2\text{ V}$, $V_{CC} = 3\text{ V}$, $V_{(SW)} = 4.2\text{ V}$ (unless otherwise noted)

PARAMETER	TEST CONDITIONS	MIN	TYP	MAX	UNIT	
$t_{PD}^{(1)}$	Propagation delay					
		F_ON \uparrow ↓ - G_IGBT \uparrow ↓		50		ns
		SW ON after $V_{(SW)}$ dips from $V_{(ZERO)}$		45		ns
		SW OFF after $I_{(SW)}$ exceeds $I_{(PEAK)}$		270		ns
		XFULL \downarrow after $V_{(SW)}$ exceeds $V_{(FULL)}$		400		ns
		SW ON after CHG \uparrow		12		μs
	SW OFF after CHG \downarrow		20		ns	

(1) Specified by design.

PIN ASSIGNMENT

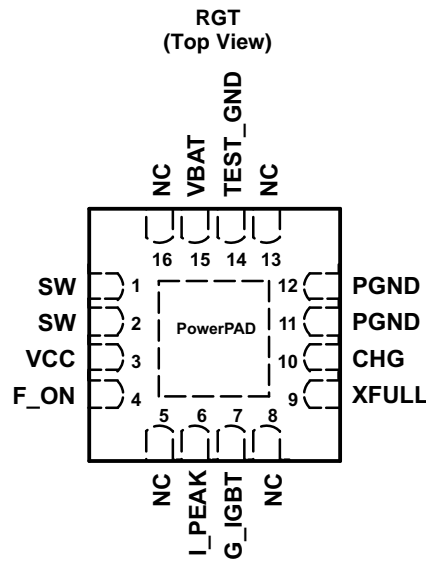

NC – No internal connection

TERMINAL FUNCTIONS

PIN NUMBER	SIGNAL	I/O	DESCRIPTION
1, 2	SW	O	Primary side switch. Connect SW to the switched side of the transformer
3	VCC	I	Power supply input. Connect VCC to an input supply from 2.7 V to 4 V. Bypass VCC to GND with a 1-μF ceramic capacitor as close as possible to the IC.
4	F_ON	I	G_IGBT control input. Drives F_ON with the flash discharge signal. A logic high on F_ON drives G_IGBT high when CHG is Low. See the <i>IGBT Driver Control</i> section for details.
5, 8, 13, 16	NC		No internal connection
6	I_PEAK	I	Primary side peak current control input. The voltage at I_PEAK sets the peak current into SW. See the <i>Programming Peak Current</i> section for details on selecting $V_{(I_PEAK)}$.
7	G_IGBT	O	IGBT gate driver output. G_IGBT swings from PGND to VCC to drive external IGBT devices.
9	XFULL	O	Charge completion indicator output. XFULL is an open-drain output that pulls low once the output is fully charged. XFULL is high impedance during charging and all fault conditions. XFULL is reseted when CHG turns Low from High. See the <i>Indicating Charging Status</i> section for details.
10	CHG	I	Charge control input. Drive CHG high to initiate charging of the output. Drive CHG low to terminate charging.
11, 12	PGND		Power ground. Connect to the ground plane.
14	TEST_GND		Used by TI, should be connected to PGND and ground plane.
15	VBAT	I	Battery voltage monitor input. Connect VBAT to an input supply from 1.6 V to 12 V. Bypass VBAT to GND with a 10-μF ceramic capacitor (C1 in Figure 1 , as close as possible to the battery) and a 1-μF ceramic capacitor (C2 in Figure 1 , as close as possible to the IC).

FUNCTIONAL BLOCK DIAGRAM

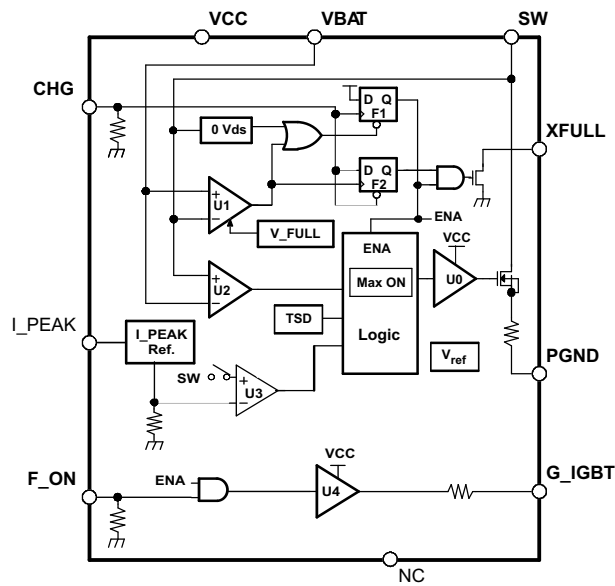

Figure 2. Functional Block Diagram

I/O Equivalent Circuits

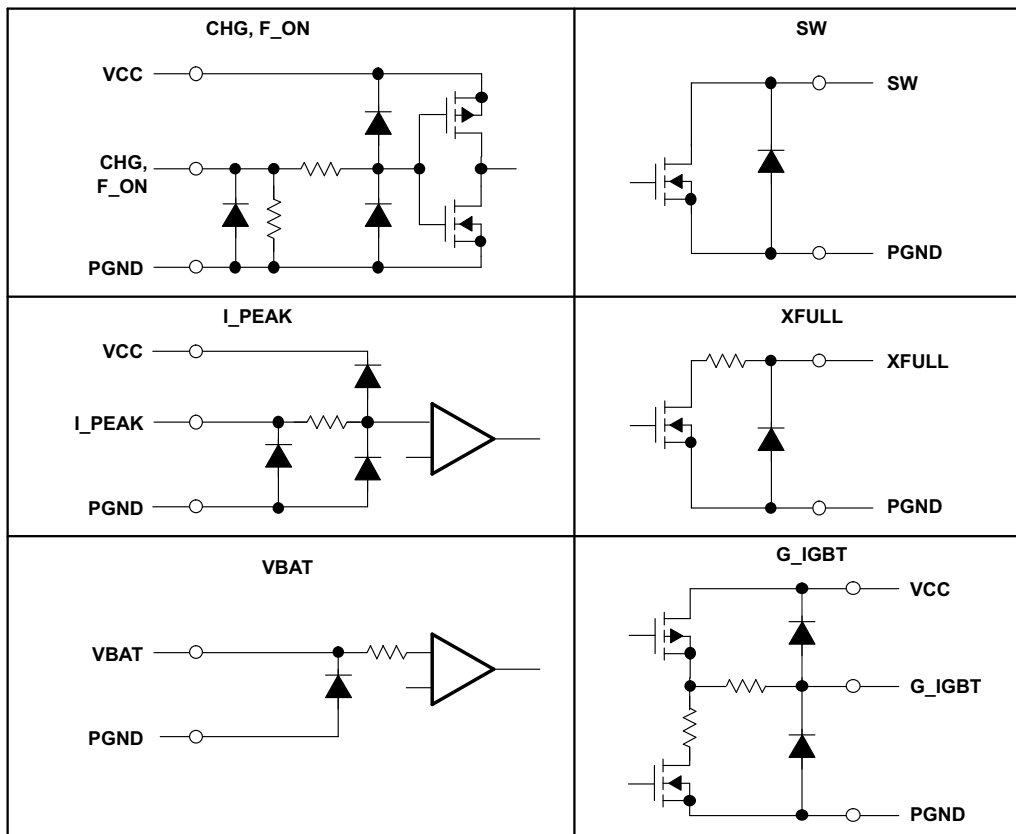

Figure 3. I/O Equivalent Circuits

PRINCIPLES OF OPERATION

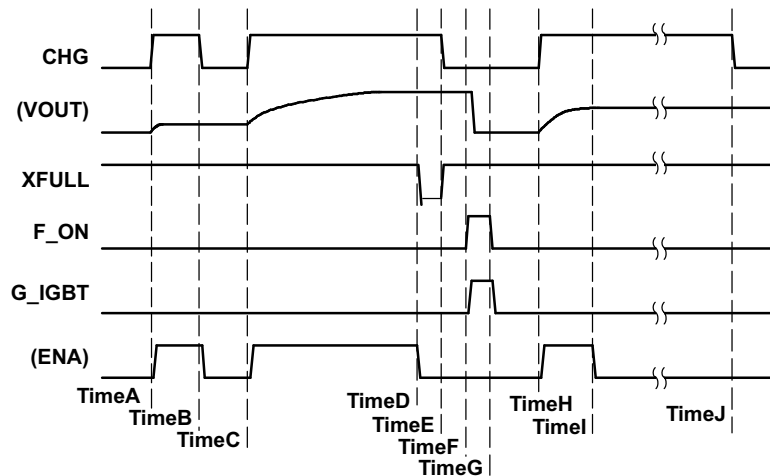

Figure 4. Whole Operation Sequence Chart

Start/Stop Charging

TPS65560 has one internal enable latch, F1, that holds the charge enable (*ON/OFF* status) of the device. See [Figure 2](#).

The only way to *start* charging is to input $\text{CHG}\hat{=}$ (see time A/C/H in [Figure 4](#)). Each time $\text{CHG}\hat{=}$ is applied, the TPS65560 starts charging.

There are three trigger events to *stop* charging:

1. Forced *stop* by inputting $\text{CHG} = \text{L}$ from the controller (see timeB in [Figure 4](#)).
2. Automatic *stop* by detecting a full charge. VOUT reaches the target value (see TimeD in [Figure 4](#)).
3. Protected *stop* by detecting an over current function (OV_{DS}) trigger at SW pin (see TimeI in [Figure 4](#)).

Indicating Charging Status

When the charging operation is complete, the TPS65560 drives the charge completion indicator pin, XFULL, to GND. A controller can detect the status of the device as a logic signal when connected through a pullup resistor, R1 (see [Figure 1](#)).

The XFULL output enables the controller to detect the OV_{DS} protection status. If OV_{DS} protection occurs, XFULL never goes L during $\text{CHG} = \text{H}$. Therefore, the controller detects OV_{DS} protection by measuring the time from CHG high to XFULL low. If the time to XFULL low is longer than the maximum designed charge time, then an OV_{DS} protection occurred.

The device starts charging at *timeH*, and OV_{DS} protection occurs at *TimeI* (see [Figure 4](#)). At *TimeI*, XFULL stays H. At *TimeJ*, the controller detects OV_{DS} protection through the expiration of a timer ends and then sets CHG to low to terminate the operation.

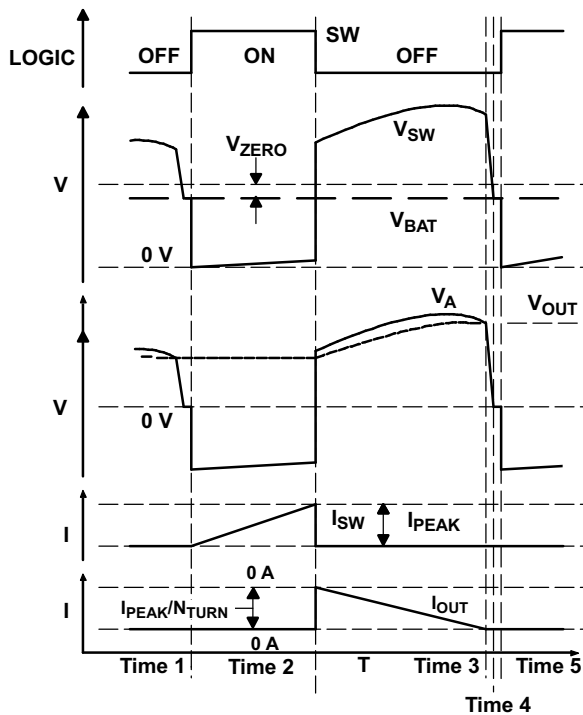

Figure 5. Timing Diagram at One Switching Cycle

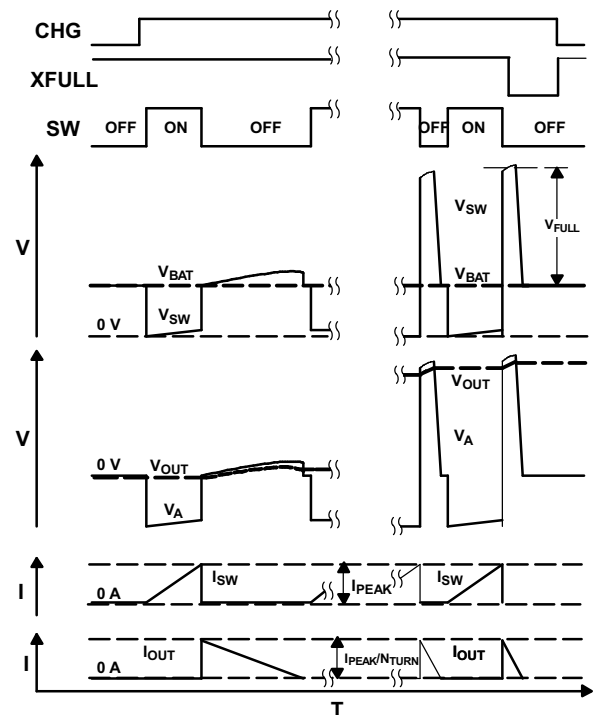

Figure 6. Timing Diagram at Beginning/Ending

Control Charging

The TPS65560 provides three comparators to control charging. Figure 2 shows the block diagram of TPS65560 and Figure 5 shows a timing diagram of one switch cycle. Note that emphasis is placed on Time1 and Time3 of the waveform in Figure 5.

While SW is ON (Time1 to Time2 in Figure 5), U3 monitors current flow through the integrated power switch from SW pin to GND. When $I_{(SW)}$ exceeds $I_{(PEAK)}$, SW turns OFF (Time2 in Figure 5).

When SW turns OFF (Time2 in Figure 5), the magnetic energy in the transformer starts discharging. Meanwhile, U2 monitors the kickback voltage at the SW terminal. As the energy is discharging, the kickback voltage is increasing according to the increase of V_O (Time2 to Time3 in Figure 5). When almost all energy is discharged, the system cannot continue rectification via the diode, and the charging current of I_O goes to zero (Times3 in Figure 5). After rectification stops, the small amount of energy left in the transformer is released via parasitic paths, and the kickback voltage reaches zero (Time3 to Time4 in Figure 5). During this period, U2 makes SW turn ON when $(V_{(SW)} - V_{BAT})$ dips from $V_{(ZERO)}$ (Time5 in Figure 5). In the actual circuit, the period between Time4 and Time5 in Figure 5 is small or does not appear dependent on the delay time of the U2 detection to SW ON.

U1 also monitors the kickback voltage. When $(V_{(SW)} - V_{BAT})$ exceeds $V_{(FULL)}$, the TPS65560 stops charging (see Figure 6).

In Figure 5 and Figure 6, ON time is always the same period in every switch cycle. The ON time is calculated by Equation 1. L and $I_{(PEAK)}$ are selected to ensure that t_{ON} does not exceed the MAX ON time (t_{MAX}).

$$t_{ON} = L \frac{I_{PEAK}}{V_{BAT}} \quad (1)$$

The *OFF* time is dependant on output voltage. As the output voltage gets higher, the *OFF* time gets shorter (see [Equation 2](#)).

$$t_{OFF} = N_{TURN} \times L \frac{I_{PEAK}}{V_{OUT}} \tag{2}$$

Programming Peak Current

The TPS65560 provides a method to program the peak primary current with a voltage applied to the I_PEAK pin. [Figure 7](#) shows how to program I_(PEAK).

The I_PEAK input is treated as a logic input below V_(PKL) (0.6 V) and above V_(PKH) (2.4 V). Between V_(PKL) and V_(PKH), I_PEAK input is treated as an analog input. Using this characteristic, I_(PEAK) can be set by a logic signal or by an analog input.

Typical usages of this function are:

1. Setting the peak charging currents based on the battery voltage. Larger I_(PEAK) for a fully charged battery and lower I_(PEAK) for a discharged battery.
2. Reducing I_(PEAK) when powering a zooming lens motor. This avoids inadvertent shutdowns due to large current from the battery.

In [Figure 1](#), three optional connections to I_PEAK are shown.

1. Use the controller to treat I_PEAK as the logic input pin. This option is the easiest.
2. Use a D/A converter to force I_(PEAK) to follow analog information, such as battery voltage.
3. Use an analog circuit to achieve the same results as the D/A converter.

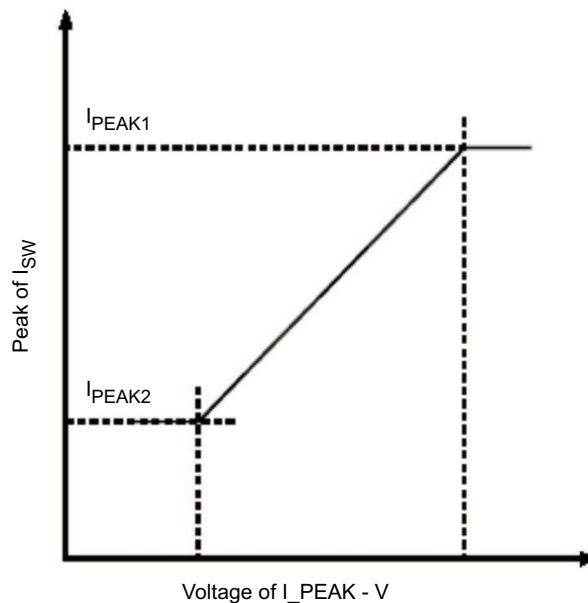

Figure 7. I_PEAK vs I_(sw)

IGBT Driver Control

The IGBT driver is provided by the TPS65560. The driver voltage depends on VCC. TPS65560 has a mask filter as shown in Figure 8. The mask does not have hysteresis; therefore, there is no wait time from CHG forcing Low after FULL CHARGE to F_ON turning High.

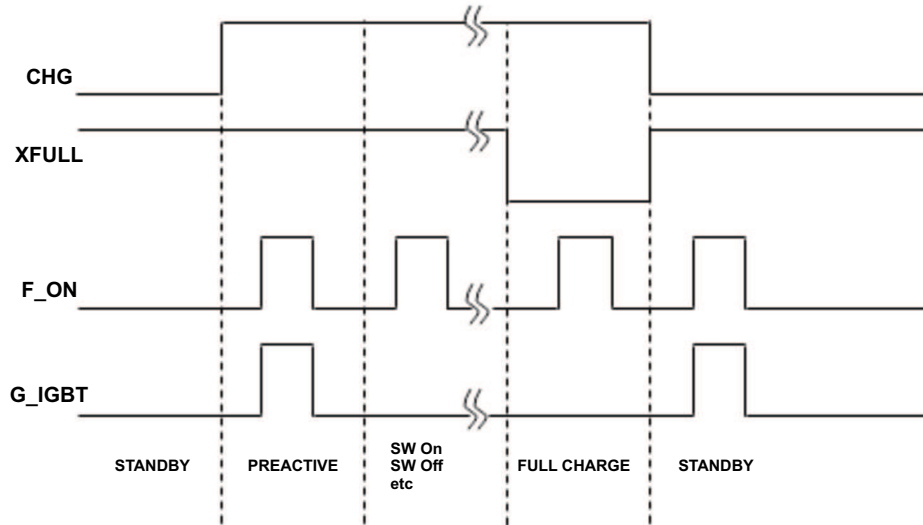

Figure 8. IGBT Timing Diagram

Protections

TPS65560 provides four protection mechanisms: max on time, max off time, thermal disable, and overcurrent shutdown.

MAX On Time

To prevent a condition such as pulling current from a poor power source (i.e., an almost empty battery), and never reaching peak current, the TPS65560 provides a maximum ON time function. If the ON time exceeds t_{MAX} , the TPS5560 is forced OFF regardless of $I_{(PEAK)}$ detection.

MAX Off Time

To prevent a condition such as never increasing the voltage at the SW pin when the internal FET is OFF, the TPS65560 provides a maximum OFF time function. If the OFF time exceeds t_{MIN} , the TPS65560 is forced ON regardless of $V_{(ZERO)}$ detection.

Thermal Disable

Once the TPS65560 die temperature reaches 160°C, all functions stop. Once the die cools below 160°C, the TPS65560 restarts charging if CHG remains high during the entire overtemperature condition.

Overcurrent Shutdown to Monitor V_{DS} at the SW Pin (OV_{DS})

The TPS65560 provides an overvoltage monitor function of the SW pin. The TPS65560 is latched off if the voltage on the SW pin is above OV_{DS} during the switch ON time (see Figure 4 and its descriptions).

This function protects against short-circuits on the primary side of the transformer. A short-circuit of the primary side shorts the battery voltage to GND. SW pin can damage the device if not protected.

PACKAGING INFORMATION

Orderable Device	Status (1)	Package Type	Package Drawing	Pins	Package Qty	Eco Plan (2)	Lead finish/ Ball material (6)	MSL Peak Temp (3)	Op Temp (°C)	Device Marking (4/5)	Samples
TPS65560RGTR	ACTIVE	VQFN	RGT	16	3000	RoHS & Green	NIPDAU	Level-2-260C-1 YEAR	-35 to 85	BPR	Samples
TPS65560RGTT	ACTIVE	VQFN	RGT	16	250	RoHS & Green	NIPDAU	Level-2-260C-1 YEAR	-35 to 85	BPR	Samples

(1) The marketing status values are defined as follows:

ACTIVE: Product device recommended for new designs.

LIFEBUY: TI has announced that the device will be discontinued, and a lifetime-buy period is in effect.

NRND: Not recommended for new designs. Device is in production to support existing customers, but TI does not recommend using this part in a new design.

PREVIEW: Device has been announced but is not in production. Samples may or may not be available.

OBsolete: TI has discontinued the production of the device.

(2) **RoHS:** TI defines "RoHS" to mean semiconductor products that are compliant with the current EU RoHS requirements for all 10 RoHS substances, including the requirement that RoHS substance do not exceed 0.1% by weight in homogeneous materials. Where designed to be soldered at high temperatures, "RoHS" products are suitable for use in specified lead-free processes. TI may reference these types of products as "Pb-Free".

RoHS Exempt: TI defines "RoHS Exempt" to mean products that contain lead but are compliant with EU RoHS pursuant to a specific EU RoHS exemption.

Green: TI defines "Green" to mean the content of Chlorine (Cl) and Bromine (Br) based flame retardants meet JS709B low halogen requirements of <=1000ppm threshold. Antimony trioxide based flame retardants must also meet the <=1000ppm threshold requirement.

(3) MSL, Peak Temp. - The Moisture Sensitivity Level rating according to the JEDEC industry standard classifications, and peak solder temperature.

(4) There may be additional marking, which relates to the logo, the lot trace code information, or the environmental category on the device.

(5) Multiple Device Markings will be inside parentheses. Only one Device Marking contained in parentheses and separated by a "~" will appear on a device. If a line is indented then it is a continuation of the previous line and the two combined represent the entire Device Marking for that device.

(6) Lead finish/Ball material - Orderable Devices may have multiple material finish options. Finish options are separated by a vertical ruled line. Lead finish/Ball material values may wrap to two lines if the finish value exceeds the maximum column width.

Important Information and Disclaimer:The information provided on this page represents TI's knowledge and belief as of the date that it is provided. TI bases its knowledge and belief on information provided by third parties, and makes no representation or warranty as to the accuracy of such information. Efforts are underway to better integrate information from third parties. TI has taken and continues to take reasonable steps to provide representative and accurate information but may not have conducted destructive testing or chemical analysis on incoming materials and chemicals. TI and TI suppliers consider certain information to be proprietary, and thus CAS numbers and other limited information may not be available for release.

In no event shall TI's liability arising out of such information exceed the total purchase price of the TI part(s) at issue in this document sold by TI to Customer on an annual basis.

TAPE AND REEL INFORMATION

QUADRANT ASSIGNMENTS FOR PIN 1 ORIENTATION IN TAPE

*All dimensions are nominal

Device	Package Type	Package Drawing	Pins	SPQ	Reel Diameter (mm)	Reel Width W1 (mm)	A0 (mm)	B0 (mm)	K0 (mm)	P1 (mm)	W (mm)	Pin1 Quadrant
TPS65560RGTR	VQFN	RGT	16	3000	330.0	12.4	3.3	3.3	1.1	8.0	12.0	Q2
TPS65560RGTT	VQFN	RGT	16	250	180.0	12.4	3.3	3.3	1.1	8.0	12.0	Q2

TAPE AND REEL BOX DIMENSIONS

*All dimensions are nominal

Device	Package Type	Package Drawing	Pins	SPQ	Length (mm)	Width (mm)	Height (mm)
TPS65560RGTR	VQFN	RGT	16	3000	346.0	346.0	33.0
TPS65560RGTT	VQFN	RGT	16	250	210.0	185.0	35.0

RGT 16

GENERIC PACKAGE VIEW

VQFN - 1 mm max height

PLASTIC QUAD FLATPACK - NO LEAD



Images above are just a representation of the package family, actual package may vary.
Refer to the product data sheet for package details.

4203495/1



SIDE WALL METAL THICKNESS DIM A	
OPTION 1	OPTION 2
0.1	0.2



4222419/D 04/2022

NOTES:

1. All linear dimensions are in millimeters. Any dimensions in parenthesis are for reference only. Dimensioning and tolerancing per ASME Y14.5M.
2. This drawing is subject to change without notice.
3. The package thermal pad must be soldered to the printed circuit board for thermal and mechanical performance.

EXAMPLE STENCIL DESIGN

RGT0016C

VQFN - 1 mm max height

PLASTIC QUAD FLATPACK - NO LEAD



SOLDER PASTE EXAMPLE
BASED ON 0.125 mm THICK STENCIL

EXPOSED PAD 17:
85% PRINTED SOLDER COVERAGE BY AREA UNDER PACKAGE
SCALE:25X

4222419/D 04/2022

NOTES: (continued)

6. Laser cutting apertures with trapezoidal walls and rounded corners may offer better paste release. IPC-7525 may have alternate design recommendations.

IMPORTANT NOTICE AND DISCLAIMER

TI PROVIDES TECHNICAL AND RELIABILITY DATA (INCLUDING DATA SHEETS), DESIGN RESOURCES (INCLUDING REFERENCE DESIGNS), APPLICATION OR OTHER DESIGN ADVICE, WEB TOOLS, SAFETY INFORMATION, AND OTHER RESOURCES "AS IS" AND WITH ALL FAULTS, AND DISCLAIMS ALL WARRANTIES, EXPRESS AND IMPLIED, INCLUDING WITHOUT LIMITATION ANY IMPLIED WARRANTIES OF MERCHANTABILITY, FITNESS FOR A PARTICULAR PURPOSE OR NON-INFRINGEMENT OF THIRD PARTY INTELLECTUAL PROPERTY RIGHTS.

These resources are intended for skilled developers designing with TI products. You are solely responsible for (1) selecting the appropriate TI products for your application, (2) designing, validating and testing your application, and (3) ensuring your application meets applicable standards, and any other safety, security, regulatory or other requirements.

These resources are subject to change without notice. TI grants you permission to use these resources only for development of an application that uses the TI products described in the resource. Other reproduction and display of these resources is prohibited. No license is granted to any other TI intellectual property right or to any third party intellectual property right. TI disclaims responsibility for, and you will fully indemnify TI and its representatives against, any claims, damages, costs, losses, and liabilities arising out of your use of these resources.

TI's products are provided subject to [TI's Terms of Sale](#) or other applicable terms available either on [ti.com](https://www.ti.com) or provided in conjunction with such TI products. TI's provision of these resources does not expand or otherwise alter TI's applicable warranties or warranty disclaimers for TI products.

TI objects to and rejects any additional or different terms you may have proposed.

Mailing Address: Texas Instruments, Post Office Box 655303, Dallas, Texas 75265
Copyright © 2023, Texas Instruments Incorporated