

## DLP230KP .23 HD DMD

### 1 Features

- Ultra compact 0.23-Inch (5.95-mm) diagonal micromirror array
  - Displays 1280 × 720 pixels on the screen
  - 5.4 μm micromirror pitch
  - 17° micromirror tilt (relative to flat surface)
  - Side illumination for optimal efficiency and optical engine size
  - Polarization independent aluminum micromirror surface
- 8-Bit SubLVDS input data bus
- Dedicated DLPC3434 controller for display applications
- Dedicated DLPA2000, DLPA2005, or DLPA3000 PMIC/LED driver for reliable operation

### 2 Display Applications

- Ultra mobile, ultra low power Pico projectors
- Phone, tablet and laptop
- Smart speaker
- Smart home

### 3 Description

The DLP230KP digital micromirror device (DMD) is a digitally controlled micro-opto-electromechanical system (MOEMS) spatial light modulator (SLM). When coupled to an appropriate optical system, the device DMD displays a crisp and high quality HD image or video. This chipset comprises this DMD and the [DLPC3434](#) controller. The [DLPA2000](#), [DLPA2005](#), and [DLPA3000](#) PMIC/LED drivers also support this chipset. The compact physical size of the device applies to portable equipment where high image quality, small form factor, and low power are important.

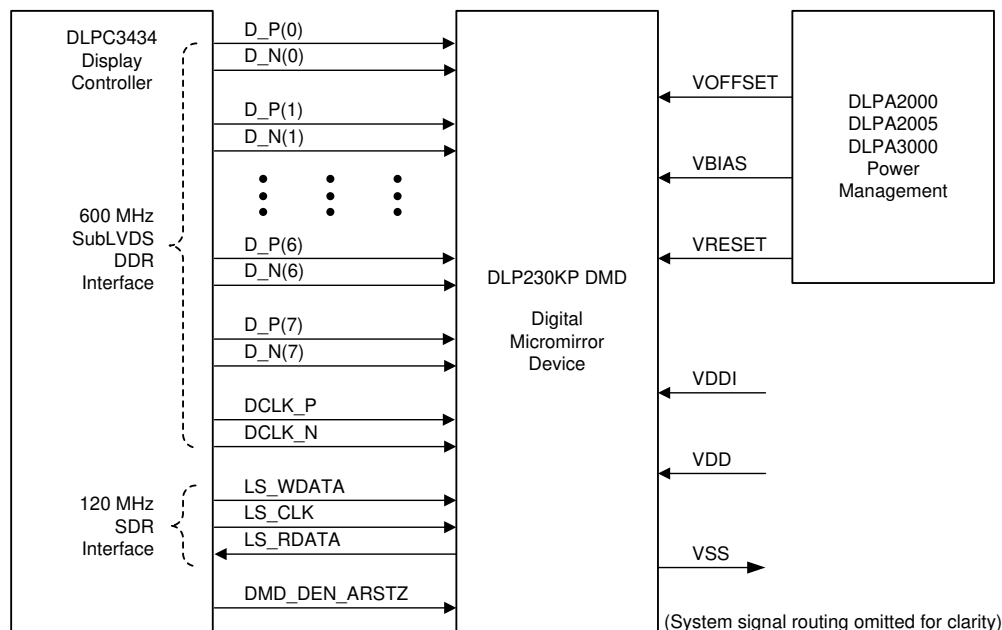
Visit the [Getting Started with TI DLP®Pico™ Display Technology](#) page to learn more about DMD technology.

The DMD includes established resources to help the user accelerate the design cycle, which include [production ready optical modules](#), [optical modules manufacturers](#), and [design houses](#).

#### Device Information

PART NUMBER	PACKAGE <sup>(1)</sup>	BODY SIZE (NOM)
DLP230KP	FQP (54)	16.8 mm × 5.92 mm × 3.58 mm

- (1) For all available packages, see the orderable addendum at the end of the data sheet.



#### Simplified Application



## Table of Contents

<b>1 Features</b> .....	1	7.6 Micromirror Array Temperature Calculation.....	23
<b>2 Display Applications</b> .....	1	7.7 Micromirror Landed-On/Landed-Off Duty Cycle.....	24
<b>3 Description</b> .....	1	<b>8 Application and Implementation</b> .....	28
<b>4 Revision History</b> .....	2	8.1 Application Information.....	28
<b>5 Pin Configuration and Functions</b> .....	3	8.2 Typical Application.....	29
<b>6 Specifications</b> .....	6	<b>9 Power Supply Recommendations</b> .....	31
6.1 Absolute Maximum Ratings.....	6	9.1 Power Supply Power-Up Procedure.....	31
6.2 Storage Conditions.....	7	9.2 Power Supply Power-Down Procedure.....	31
6.3 ESD Ratings.....	7	9.3 Power Supply Sequencing Requirements.....	32
6.4 Recommended Operating Conditions.....	7	<b>10 Layout</b> .....	34
6.5 Thermal Information.....	10	10.1 Layout Guidelines.....	34
6.6 Electrical Characteristics.....	10	10.2 Layout Example.....	34
6.7 Timing Requirements.....	11	<b>11 Device and Documentation Support</b> .....	35
6.8 Switching Characteristics <sup>(1)</sup> .....	15	11.1 Device Support.....	35
6.9 System Mounting Interface Loads.....	16	11.2 Chipset Resources.....	35
6.10 Micromirror Array Physical Characteristics.....	17	11.3 Receiving Notification of Documentation Updates..	35
6.11 Micromirror Array Optical Characteristics.....	18	11.4 Support Resources.....	36
6.12 Window Characteristics.....	20	11.5 Trademarks.....	36
6.13 Chipset Component Usage Specification.....	20	11.6 Electrostatic Discharge Caution.....	36
<b>7 Detailed Description</b> .....	21	11.7 Glossary.....	36
7.1 Overview.....	21	<b>12 Mechanical, Packaging, and Orderable Information</b> .....	37
7.2 Functional Block Diagram.....	21	12.1 Package Option Addendum.....	38
7.3 Feature Description.....	22		
7.4 Device Functional Modes.....	22		
7.5 Optical Interface and System Image Quality Considerations.....	22		

## 4 Revision History

NOTE: Page numbers for previous revisions may differ from page numbers in the current version.

<b>Changes from Revision B (April 2022) to Revision C (May 2022)</b>	<b>Page</b>
• Updated Absolute Maximum Ratings disclosure to the latest TI standard.....	6
• Updated <i>Micromirror Array Optical Characteristics</i> .....	18
• Added <i>Third-Party Products Disclaimer</i> .....	35
<b>Changes from Revision A (September 2018) to Revision B (April 2022)</b>	<b>Page</b>
• Updated the numbering format for tables, figures, and cross-references throughout the document.....	1
• Updated maximum  T <sub>DELTA</sub>   specification from "25°C" to "15°C" in <i>Recommended Operating Conditions</i> .....	10
• Changed <i>Related Links</i> section title to <i>Chipset Resources</i> .....	35
• Changed <i>Related Links</i> table title to <i>Chipset Resources</i> .....	35
<b>Changes from Revision * (July 2018) to Revision A (September 2018)</b>	<b>Page</b>
• Updated <i>Simplified Application</i> .....	1
• Changed data sheet status from <i>Advance Information</i> to <i>Production Data</i> .....	1

## 5 Pin Configuration and Functions

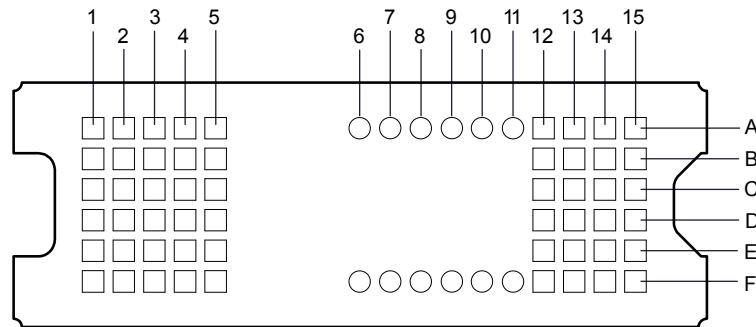


Figure 5-1. FQP Package, 54-Pin CLGA (Bottom View)

Table 5-1. Pin Functions – Connector Pins

PIN <sup>(1)</sup>		TYPE	SIGNAL	DATA RATE	DESCRIPTION	PACKAGE NET LENGTH <sup>(2)</sup> (mm)
NAME	NO.					
<b>DATA INPUTS</b>						
D_N(0)	A2	I	SubLVDS	Double	Data, negative	1.96
D_N(1)	A1	I	SubLVDS	Double	Data, negative	1.42
D_N(2)	C1	I	SubLVDS	Double	Data, negative	1.35
D_N(3)	B4	I	SubLVDS	Double	Data, negative	3.36
D_N(4)	F5	I	SubLVDS	Double	Data, negative	4.29
D_N(5)	D4	I	SubLVDS	Double	Data, negative	3.20
D_N(6)	E1	I	SubLVDS	Double	Data, negative	1.76
D_N(7)	F3	I	SubLVDS	Double	Data, negative	2.66
D_P(0)	A3	I	SubLVDS	Double	Data, positive	1.97
D_P(1)	B1	I	SubLVDS	Double	Data, positive	1.49
D_P(2)	C2	I	SubLVDS	Double	Data, positive	1.44
D_P(3)	A4	I	SubLVDS	Double	Data, positive	3.45
D_P(4)	E5	I	SubLVDS	Double	Data, positive	4.32
D_P(5)	D5	I	SubLVDS	Double	Data, positive	3.27
D_P(6)	E2	I	SubLVDS	Double	Data, positive	1.85
D_P(7)	F2	I	SubLVDS	Double	Data, positive	2.75
DCLK_N	C3	I	SubLVDS	Double	Clock, negative	1.94
DCLK_P	D3	I	SubLVDS	Double	Clock, positive	2.02
<b>CONTROL INPUTS</b>						
LS_WDATA	A12	I	LPSDR <sup>(1)</sup>	Single	Write data for low speed interface.	2.16
LS_CLK	B12	I	LPSDR	Single	Clock for low-speed interface.	3.38
DMD_DEN_ARSTZ	B14	I	LPSDR	Single	Asynchronous reset DMD signal. A low signal places the DMD in reset. A high signal releases the DMD from reset and places it in active mode.	0.67
DMD_DEN_ARSTZ	F1	I	LPSDR	Single		14.90
LS_RDATA	C13	O	LPSDR	Single	Read data for low-speed interface.	2.44
<b>POWER</b>						
V <sub>BIAS</sub> <sup>(3)</sup>	A15	Power			Supply voltage for positive bias level at micromirrors.	
V <sub>BIAS</sub> <sup>(3)</sup>	A5	Power				

**Table 5-1. Pin Functions – Connector Pins (continued)**

PIN <sup>(1)</sup>		TYPE	SIGNAL	DATA RATE	DESCRIPTION	PACKAGE NET LENGTH <sup>(2)</sup> (mm)
NAME	NO.					
V <sub>OFFSET</sub> <sup>(3)</sup>	F13	Power			Supply voltage for HVCMOS core logic. Supply voltage for stepped high level at micromirror address electrodes. Supply voltage for offset level at micromirrors.	
V <sub>OFFSET</sub> <sup>(3)</sup>	F4	Power				
V <sub>RESET</sub>	B15	Power			Supply voltage for negative reset level at micromirrors.	
V <sub>RESET</sub>	B5	Power				
V <sub>DD</sub> <sup>(3)</sup>	C15	Power			Supply voltage for LVCMOS core logic. Supply voltage for LPSDR inputs. Supply voltage for normal high level at micromirror address electrodes.	
V <sub>DD</sub>	C5	Power				
V <sub>DD</sub>	D14	Power				
V <sub>DD</sub>	D15	Power				
V <sub>DD</sub>	E14	Power				
V <sub>DD</sub>	E15	Power				
V <sub>DD</sub>	F14	Power				
V <sub>DD</sub>	F15	Power				
V <sub>DDI</sub>	C14	Power			Supply voltage for SubLVDS receivers.	
V <sub>DDI</sub>	C4	Power				
V <sub>DDI</sub>	D13	Power				
V <sub>DDI</sub>	E13	Power				
V <sub>SS</sub>	A13	Ground			Common return. Ground for all power.	
V <sub>SS</sub>	A14	Ground				
V <sub>SS</sub>	B13	Ground				
V <sub>SS</sub>	B2	Ground				
V <sub>SS</sub>	B3	Ground				
V <sub>SS</sub>	C12	Ground				
V <sub>SS</sub>	D1	Ground				
V <sub>SS</sub>	D12	Ground				
V <sub>SS</sub>	D2	Ground				
V <sub>SS</sub>	E12	Ground				
V <sub>SS</sub>	E3	Ground				
V <sub>SS</sub>	E4	Ground				
V <sub>SS</sub>	F12	Ground				

- (1) Low speed interface is LPSDR and adheres to the Electrical Characteristics and AC/DC Operating Conditions table in JEDEC Standard No. 209B, *Low Power Double Data Rate (LPDDR)*. See [JESD209B](#).
- (2) Net trace lengths inside the package:  
Relative dielectric constant for the FQP ceramic package is 9.8.  
Propagation speed = 11.8 / sqrt(9.8) = 3.769 in/ns.  
Propagation delay = 0.265 ns/inch = 265 ps/in = 10.43 ps/mm.
- (3) The following power supplies are all required to operate the DMD: V<sub>DD</sub>, V<sub>DDI</sub>, V<sub>OFFSET</sub>, V<sub>BIAS</sub>, V<sub>RESET</sub>. All V<sub>SS</sub> connections are also required.

**Table 5-2. Pin Functions – Test Pads**

<b>NUMBER</b>	<b>SYSTEM BOARD</b>
A6	Do not connect
A7	Do not connect
A8	Do not connect
A9	Do not connect
A10	Do not connect
A11	Do not connect
F6	Do not connect
F7	Do not connect
F8	Do not connect
F9	Do not connect
F10	Do not connect
F11	Do not connect

## 6 Specifications

### 6.1 Absolute Maximum Ratings

over operating free-air temperature range (unless otherwise noted<sup>(1)</sup>)

			MIN	MAX	UNIT
Supply voltage	$V_{DD}$	Supply voltage for LVCMOS core logic <sup>(2)</sup> Supply voltage for LPSDR low speed interface	-0.5	2.3	V
	$V_{DDI}$	Supply voltage for SubLVDS receivers <sup>(2)</sup>	-0.5	2.3	V
	$V_{OFFSET}$	Supply voltage for HVCMOS and micromirror electrode <sup>(2) (3)</sup>	-0.5	11	V
	$V_{BIAS}$	Supply voltage for micromirror electrode <sup>(2)</sup>	-0.5	19	V
	$V_{RESET}$	Supply voltage for micromirror electrode <sup>(2)</sup>	-15	0.5	V
	$ V_{DDI}-V_{DD} $	Supply voltage delta (absolute value) <sup>(4)</sup>		0.3	V
	$ V_{BIAS}-V_{OFFSET} $	Supply voltage delta (absolute value) <sup>(5)</sup>		11	V
	$ V_{BIAS}-V_{RESET} $	Supply voltage delta (absolute value) <sup>(6)</sup>		34	V
Input voltage	Input voltage for other inputs LPSDR <sup>(2)</sup>		-0.5	$V_{DD} + 0.5$	V
	Input voltage for other inputs SubLVDS <sup>(2) (7)</sup>		-0.5	$V_{DDI} + 0.5$	V
Input pins	$ V_{ID} $	SubLVDS input differential voltage (absolute value) <sup>(7)</sup>		810	mV
	$I_{ID}$	SubLVDS input differential current		10	mA
Clock frequency	$f_{clock}$	Clock frequency for low speed interface LS_CLK		130	MHz
	$f_{clock}$	Clock frequency for high speed interface DCLK		620	MHz
Environmental	$T_{ARRAY}$ and $T_{WINDOW}$	Temperature – operational <sup>(8)</sup>	-20	90	°C
		Temperature – non-operational <sup>(8)</sup>	-40	90	°C
	$ T_{DELTA} $	Absolute temperature delta between any point on the window edge and the ceramic test point TP1 <sup>(9)</sup>		30	°C
	$T_{DP}$	Dew Point - operating and non-operating		81	°C

- (1) Operation outside the Absolute Maximum Ratings may cause permanent device damage. Absolute Maximum Ratings do not imply functional operation of the device at these or any other conditions beyond those listed under Recommended Operating Conditions. If outside the Recommended Operating Conditions but within the Absolute Maximum Ratings, the device may not be fully functional, and this may affect device reliability, functionality, performance, and shorten the device lifetime.
- (2) All voltage values are with respect to the ground terminals ( $V_{SS}$ ). The following power supplies are all required to operate the DMD:  $V_{DD}$ ,  $V_{DDI}$ ,  $V_{OFFSET}$ ,  $V_{BIAS}$ , and  $V_{RESET}$ . All  $V_{SS}$  connections are also required.
- (3)  $V_{OFFSET}$  supply transients must fall within specified voltages.
- (4) Exceeding the recommended allowable absolute voltage difference between  $V_{DDI}$  and  $V_{DD}$  may result in excessive current draw.
- (5) Exceeding the recommended allowable absolute voltage difference between  $V_{BIAS}$  and  $V_{OFFSET}$  may result in excessive current draw.
- (6) Exceeding the recommended allowable absolute voltage difference between  $V_{BIAS}$  and  $V_{RESET}$  may result in excessive current draw.
- (7) This maximum input voltage rating applies when each input of a differential pair is at the same voltage potential. SubLVDS differential inputs must not exceed the specified limit or damage may result to the internal termination resistors.
- (8) The highest temperature of the active array (as calculated in Section 7.6) or of any point along the window edge is defined in Figure 7-1. The location of thermal test point TP2 in Figure 7-1 is intended to measure the highest window edge temperature. If a particular application causes another point on the window edge to be at a higher temperature, that point should be used.
- (9) Temperature delta is the highest difference between the ceramic test point 1 (TP1) and anywhere on the window edge as shown in Figure 7-1. The window test point TP2 shown in Figure 7-1 is intended to result in the worst case delta. If a particular application causes another point on the window edge to result in a larger delta temperature, that point should be used.

## 6.2 Storage Conditions

Applicable for the DMD as a component or non-operating in a system.

		MIN	MAX	UNIT
T <sub>DMD</sub>	DMD storage temperature	-40	85	°C
T <sub>DP</sub>	Average dew point temperature (non-condensing) <sup>(1)</sup>		24	°C
T <sub>DP-ELR</sub>	Elevated dew point temperature range (non-condensing) <sup>(2)</sup>	28	36	°C
CT <sub>ELR</sub>	Cumulative time in elevated dew point temperature range		6	months

- (1) The average over time (including storage and operating) that the device is not in the elevated dew point temperature range.  
(2) Exposure to dew point temperatures in the elevated range during storage and operation should be limited to less than a total cumulative time of CT<sub>ELR</sub>.

## 6.3 ESD Ratings

		VALUE	UNIT
V <sub>(ESD)</sub>	Electrostatic discharge Human body model (HBM), per ANSI/ESDA/JEDEC JS-001 <sup>(1)</sup>	±2000	V

- (1) JEDEC document JEP155 states that 500-V HBM allows safe manufacturing with a standard ESD control process.

## 6.4 Recommended Operating Conditions

Over operating free-air temperature range (unless otherwise noted)<sup>(1) (2)</sup>

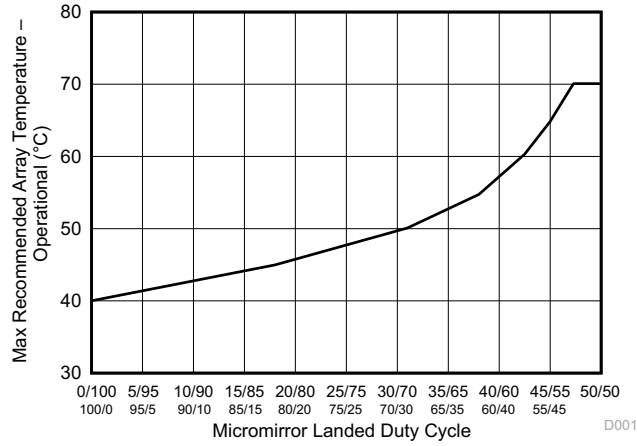
		MIN	NOM	MAX	UNIT
<b>SUPPLY VOLTAGE RANGE<sup>(3)</sup></b>					
V <sub>DD</sub>	Supply voltage for LVC MOS core logic Supply voltage for LPSDR low-speed interface	1.65	1.8	1.95	V
V <sub>DDI</sub>	Supply voltage for SubLVDS receivers	1.65	1.8	1.95	V
V <sub>OFFSET</sub>	Supply voltage for HVCMOS and micromirror electrode <sup>(4)</sup>	9.5	10	10.5	V
V <sub>BIAS</sub>	Supply voltage for mirror electrode	17.5	18	18.5	V
V <sub>RESET</sub>	Supply voltage for micromirror electrode	-14.5	-14	-13.5	V
V <sub>DDI</sub> -V <sub>DD</sub>	Supply voltage delta (absolute value) <sup>(5)</sup>			0.3	V
V <sub>BIAS</sub> -V <sub>OFFSET</sub>	Supply voltage delta (absolute value) <sup>(6)</sup>			10.5	V
V <sub>BIAS</sub> -V <sub>RESET</sub>	Supply voltage delta (absolute value) <sup>(7)</sup>			33	V
<b>CLOCK FREQUENCY</b>					
f <sub>clock</sub>	Clock frequency for low speed interface LS_CLK <sup>(8)</sup>	108		120	MHz
f <sub>clock</sub>	Clock frequency for high speed interface DCLK <sup>(9)</sup>	300		540	MHz
	Duty cycle distortion DCLK	44%		56%	
<b>SUBLVDS INTERFACE<sup>(9)</sup></b>					
V <sub>ID</sub>	SubLVDS input differential voltage (absolute value). See <a href="#">Figure 6-8</a> , <a href="#">Figure 6-9</a>	150	250	350	mV
V <sub>CM</sub>	Common mode voltage. See <a href="#">Figure 6-8</a> , <a href="#">Figure 6-9</a>	700	900	1100	mV
V <sub>SUBLVDS</sub>	SubLVDS voltage. See <a href="#">Figure 6-8</a> , <a href="#">Figure 6-9</a>	575		1225	mV
Z <sub>LINE</sub>	Line differential impedance (PWB/trace)	90	100	110	Ω
Z <sub>IN</sub>	Internal differential termination resistance. See <a href="#">Figure 6-10</a>	80	100	120	Ω
	100-Ω differential PCB trace			152.4	mm

Over operating free-air temperature range (unless otherwise noted)<sup>(1) (2)</sup>

		MIN	NOM	MAX	UNIT
<b>ENVIRONMENTAL</b>					
T <sub>ARRAY</sub>	Array temperature – long-term operational <sup>(10) (11) (12) (13)</sup>	0		40 to 70 <sup>(12)</sup>	°C
	Array temperature – short-term operational, 25 hr max <sup>(11) (14)</sup>	–20		–10	°C
	Array temperature – short-term operational, 500 hr max <sup>(11) (14)</sup>	–10		0	°C
	Array temperature – short-term operational, 500 hr max <sup>(11) (14)</sup>	70		75	°C
T <sub>WINDOW</sub>	Window temperature – operational <sup>(15) (16)</sup>			90	°C
T <sub>DELTA</sub>	Absolute temperature difference between any point on the window edge and the ceramic test point TP1 <sup>(17)</sup>			15	°C
T <sub>DP-AVG</sub>	Average dew point temperature (non-condensing) <sup>(18)</sup>			24	°C
T <sub>DP-ELR</sub>	Elevated dew point temperature range (non-condensing) <sup>(19)</sup>	28		36	°C
CT <sub>ELR</sub>	Cumulative time in elevated dew point temperature range			6	months
ILL <sub>UV</sub>	Illumination wavelengths < 420 nm <sup>(10)</sup>			0.68	mW/cm <sup>2</sup>
ILL <sub>VIS</sub>	Illumination wavelengths between 420 nm and 700 nm			Thermally limited	
ILL <sub>IR</sub>	Illumination wavelengths > 700 nm			10	mW/cm <sup>2</sup>
ILL <sub>θ</sub>	Illumination marginal ray angle <sup>(15)</sup>			55	degrees

- (1) The functional performance of the device specified in this data sheet is achieved when operating the device within the limits defined by the [Section 6.4](#). No level of performance is implied when operating the device above or below the [Section 6.4](#) limits.
- (2) The following power supplies are all required to operate the DMD: V<sub>DD</sub>, V<sub>DDI</sub>, V<sub>OFFSET</sub>, V<sub>BIAS</sub>, and V<sub>RESET</sub>. All V<sub>SS</sub> connections are also required.
- (3) All voltage values are with respect to the ground pins (V<sub>SS</sub>).
- (4) V<sub>OFFSET</sub> supply transients must fall within specified max voltages.
- (5) To prevent excess current, the supply voltage delta |V<sub>DDI</sub> – V<sub>DD</sub>| must be less than the specified limit.
- (6) To prevent excess current, the supply voltage delta |V<sub>BIAS</sub> – V<sub>OFFSET</sub>| must be less than the specified limit.
- (7) To prevent excess current, the supply voltage delta |V<sub>BIAS</sub> – V<sub>RESET</sub>| must be less than the specified limit.
- (8) LS\_CLK must run as specified to ensure internal DMD timing for reset waveform commands.
- (9) Refer to the SubLVDS timing requirements in [Section 6.7](#).
- (10) Simultaneous exposure of the DMD to the maximum *Recommended Operating Conditions* for temperature and UV illumination will reduce device lifetime.
- (11) The array temperature cannot be measured directly and must be computed analytically from the temperature measured at test point 1 (TP1) shown in [Figure 7-1](#) and the package thermal resistance using [Section 7.6](#).
- (12) Per [Figure 6-1](#), the maximum operational array temperature should be derated based on the micromirror landed duty cycle that the DMD experiences in the end application. Refer to [Section 7.7](#) for a definition of micromirror landed duty cycle.
- (13) Long-term is defined as the usable life of the device.
- (14) Short-term is the total cumulative time over the useful life of the device.
- (15) The maximum marginal ray angle of the incoming illumination light at any point in the micromirror array, including at the pond of micromirrors (POM), should not exceed 55 degrees from the normal to the device array plane. The device window aperture has not necessarily been designed to allow incoming light at higher maximum angles to pass to the micromirrors, and the device performance has not been tested nor qualified at angles exceeding this. Illumination light exceeding this angle outside the micromirror array (including POM) will contribute to thermal limitations described in this document and may negatively affect lifetime.
- (16) Window temperature is the highest temperature on the window edge shown in [Figure 7-1](#). The location of thermal test point TP2 in [Figure 7-1](#) is intended to measure the highest window edge temperature. If a particular application causes another point on the window edge to be at a higher temperature, that point should be used.
- (17) Temperature delta is the highest difference between the ceramic test point 1 (TP1) and anywhere on the window edge shown in [Figure 7-1](#). The window test point TP2 shown in [Figure 7-1](#) is intended to result in the worst case delta temperature. If a particular application causes another point on the window edge to result in a larger delta temperature, that point should be used.
- (18) The average over time (including storage and operating) that the device is not in the 'elevated dew point temperature range'.
- (19) Exposure to dew point temperatures in the elevated range during storage and operation should be limited to less than a total cumulative time of CT<sub>ELR</sub>.





**Figure 6-1. Maximum Recommended Array Temperature – Derating Curve**

## 6.5 Thermal Information

THERMAL METRIC <sup>(1)</sup>		DLP230KP	UNIT
		FQP (CLGA)	
		54 PINS	
Thermal resistance	Active area to test point 1 (TP1) <sup>(1)</sup>	9.0	°C/W

- (1) The DMD is designed to conduct absorbed and dissipated heat to the back of the package. The cooling system must be capable of maintaining the package within the temperature range specified in the [Section 6.4](#). The total heat load on the DMD is largely driven by the incident light absorbed by the active area, although other contributions include light energy absorbed by the window aperture and electrical power dissipated by the array. Optical systems should be designed to minimize the light energy falling outside the window clear aperture since any additional thermal load in this area can significantly degrade the reliability of the device.

## 6.6 Electrical Characteristics

Over operating free-air temperature range (unless otherwise noted)<sup>(1)</sup>

PARAMETER		TEST CONDITIONS <sup>(2)</sup>	MIN	TYP	MAX	UNIT
<b>CURRENT</b>						
I <sub>DD</sub>	Supply current: V <sub>DD</sub> <sup>(3) (4)</sup>	V <sub>DD</sub> = 1.95 V			65	mA
		V <sub>DD</sub> = 1.8 V		53		
I <sub>DDI</sub>	Supply current: V <sub>DDI</sub> <sup>(3) (4)</sup>	V <sub>DDI</sub> = 1.95 V			12	mA
		V <sub>DD</sub> = 1.8 V		11		
I <sub>OFFSET</sub>	Supply current: V <sub>OFFSET</sub> <sup>(5) (6)</sup>	V <sub>OFFSET</sub> = 10.5 V			1.5	mA
		V <sub>OFFSET</sub> = 10 V		1.4		
I <sub>BIAS</sub>	Supply current: V <sub>BIAS</sub> <sup>(5) (6)</sup>	V <sub>BIAS</sub> = 18.5 V			0.3	mA
		V <sub>BIAS</sub> = 18 V		0.29		
I <sub>RESET</sub>	Supply current: V <sub>RESET</sub> <sup>(6)</sup>	V <sub>RESET</sub> = -14.5 V			-1.3	mA
		V <sub>RESET</sub> = -14 V		-1.2		
<b>POWER<sup>(7)</sup></b>						
P <sub>DD</sub>	Supply power dissipation: V <sub>DD</sub> <sup>(3) (4)</sup>	V <sub>DD</sub> = 1.95 V			126.75	mW
		V <sub>DD</sub> = 1.8 V		95.4		
P <sub>DDI</sub>	Supply power dissipation: V <sub>DDI</sub> <sup>(3) (4)</sup>	V <sub>DDI</sub> = 1.95 V			23.4	mW
		V <sub>DD</sub> = 1.8 V		19.8		
P <sub>OFFSET</sub>	Supply power dissipation: V <sub>OFFSET</sub> <sup>(5) (6)</sup>	V <sub>OFFSET</sub> = 10.5 V			15.75	mW
		V <sub>OFFSET</sub> = 10 V		14		
P <sub>BIAS</sub>	Supply power dissipation: V <sub>BIAS</sub> <sup>(5) (6)</sup>	V <sub>BIAS</sub> = 18.5 V			5.55	mW
		V <sub>BIAS</sub> = 18 V		5.22		
P <sub>RESET</sub>	Supply power dissipation: V <sub>RESET</sub> <sup>(6)</sup>	V <sub>RESET</sub> = -14.5 V			18.85	mW
		V <sub>RESET</sub> = -14 V		16.80		
P <sub>TOTAL</sub>	Supply power dissipation: Total			151.22	190.3	mW
<b>LPSDR INPUT<sup>(8)</sup></b>						
V <sub>IH(DC)</sub>	DC input high voltage <sup>(9)</sup>		0.7 × V <sub>DD</sub>		V <sub>DD</sub> + 0.3	V
V <sub>IL(DC)</sub>	DC input low voltage <sup>(9)</sup>		-0.3		0.3 × V <sub>DD</sub>	V
V <sub>IH(AC)</sub>	AC input high voltage <sup>(9)</sup>		0.8 × V <sub>DD</sub>		V <sub>DD</sub> + 0.3	V
V <sub>IL(AC)</sub>	AC input low voltage <sup>(9)</sup>		-0.3		0.2 × V <sub>DD</sub>	V
ΔV <sub>T</sub>	Hysteresis ( V <sub>T+</sub> – V <sub>T-</sub> )	<a href="#">Figure 6-10</a>	0.1 × V <sub>DD</sub>		0.4 × V <sub>DD</sub>	V
I <sub>IL</sub>	Low-level input current	V <sub>DD</sub> = 1.95 V; V <sub>I</sub> = 0 V	-100			nA
I <sub>IH</sub>	High-level input current	V <sub>DD</sub> = 1.95 V; V <sub>I</sub> = 1.95 V			100	nA
<b>LPSDR OUTPUT<sup>(10)</sup></b>						
V <sub>OH</sub>	DC output high voltage	I <sub>OH</sub> = -2 mA	0.8 × V <sub>DD</sub>			V
V <sub>OL</sub>	DC output low voltage	I <sub>OL</sub> = 2 mA			0.2 × V <sub>DD</sub>	V

Over operating free-air temperature range (unless otherwise noted)<sup>(1)</sup>

PARAMETER		TEST CONDITIONS <sup>(2)</sup>	MIN	TYP	MAX	UNIT
<b>CAPACITANCE</b>						
C <sub>IN</sub>	Input capacitance LPSDR	$f = 1 \text{ MHz}$			10	pF
	Input capacitance SubLVDS	$f = 1 \text{ MHz}$			20	pF
C <sub>OUT</sub>	Output capacitance	$f = 1 \text{ MHz}$			10	pF
C <sub>RESET</sub>	Reset group capacitance	$f = 1 \text{ MHz}; (540 \times 120) \text{ micromirrors}$	90		150	pF

- (1) Device electrical characteristics are over [Section 6.4](#) unless otherwise noted.
- (2) All voltage values are with respect to the ground pins (V<sub>SS</sub>).
- (3) To prevent excess current, the supply voltage delta  $|V_{DDI} - V_{DD}|$  must be less than the specified limit.
- (4) Supply power dissipation based on non-compressed commands and data.
- (5) To prevent excess current, the supply voltage delta  $|V_{BIAS} - V_{OFFSET}|$  must be less than the specified limit.
- (6) Supply power dissipation based on 3 global resets in 200  $\mu\text{s}$ .
- (7) The following power supplies are all required to operate the DMD: V<sub>DD</sub>, V<sub>DDI</sub>, V<sub>OFFSET</sub>, V<sub>BIAS</sub>, V<sub>RESET</sub>. All V<sub>SS</sub> connections are also required.
- (8) LPSDR specifications are for pins LS\_CLK and LS\_WDATA.
- (9) Low-speed interface is LPSDR and adheres to the Electrical Characteristics and AC/DC Operating Conditions table in JEDEC Standard No. 209B, *Low-Power Double Data Rate (LPDDR) JESD209B*.
- (10) LPSDR specification is for pin LS\_RDATA.

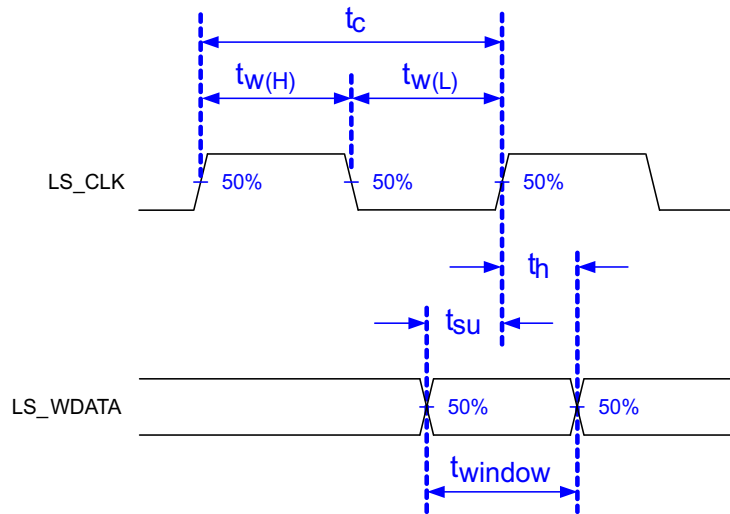
## 6.7 Timing Requirements

Device electrical characteristics are over *Recommended Operating Conditions* unless otherwise noted.

			MIN	NOM	MAX	UNIT
<b>LPSDR</b>						
t <sub>r</sub>	Rise slew rate <sup>(1)</sup>	$(30\% \text{ to } 80\%) \times V_{DD}$ , <a href="#">Figure 6-3</a>	1		3	V/ns
t <sub>f</sub>	Fall slew rate <sup>(1)</sup>	$(70\% \text{ to } 20\%) \times V_{DD}$ , <a href="#">Figure 6-3</a>	1		3	V/ns
t <sub>r</sub>	Rise slew rate <sup>(2)</sup>	$(20\% \text{ to } 80\%) \times V_{DD}$ , <a href="#">Figure 6-3</a>	0.25			V/ns
t <sub>f</sub>	Fall slew rate <sup>(2)</sup>	$(80\% \text{ to } 20\%) \times V_{DD}$ , <a href="#">Figure 6-3</a>	0.25			V/ns
t <sub>c</sub>	Cycle time LS_CLK	<a href="#">Figure 6-2</a>	7.7	8.3		ns
t <sub>W(H)</sub>	Pulse duration LS_CLK high	50% to 50% reference points, <a href="#">Figure 6-2</a>	3.1			ns
t <sub>W(L)</sub>	Pulse duration LS_CLK low	50% to 50% reference points, <a href="#">Figure 6-2</a>	3.1			ns
t <sub>su</sub>	Setup time	LS_WDATA valid before LS_CLK $\uparrow$ , <a href="#">Figure 6-2</a>	1.5			ns
t <sub>h</sub>	Hold time	LS_WDATA valid after LS_CLK $\uparrow$ , <a href="#">Figure 6-2</a>	1.5			ns
t <sub>WINDOW</sub>	Window time <sup>(1) (3)</sup>	Setup time + hold time, <a href="#">Figure 6-2</a>	3			ns
t <sub>DERATING</sub>	Window time derating <sup>(1) (3)</sup>	For each 0.25 V/ns reduction in slew rate below 1 V/ns, <a href="#">Figure 6-5</a>		0.35		ns
<b>SubLVDS</b>						
t <sub>r</sub>	Rise slew rate	20% to 80% reference points, <a href="#">Figure 6-4</a>	0.7	1		V/ns
t <sub>f</sub>	Fall slew rate	80% to 20% reference points, <a href="#">Figure 6-4</a>	0.7	1		V/ns
t <sub>c</sub>	Cycle time DCLK	<a href="#">Figure 6-6</a>	1.79	1.85		ns
t <sub>W(H)</sub>	Pulse duration DCLK high	50% to 50% reference points, <a href="#">Figure 6-6</a>	0.79			ns
t <sub>W(L)</sub>	Pulse duration DCLK low	50% to 50% reference points, <a href="#">Figure 6-6</a>	0.79			ns
t <sub>su</sub>	Setup time	D(0:7) valid before DCLK $\uparrow$ or DCLK $\downarrow$ , <a href="#">Figure 6-6</a>				
t <sub>h</sub>	Hold time	D(0:7) valid after DCLK $\uparrow$ or DCLK $\downarrow$ , <a href="#">Figure 6-6</a>				
t <sub>WINDOW</sub>	Window time	Setup time + hold time, <a href="#">Figure 6-6</a> , <a href="#">Figure 6-7</a>			0.3	ns
t <sub>LVDS-ENABLE+REFGEN</sub>	Power-up receiver <sup>(4)</sup>				2000	ns

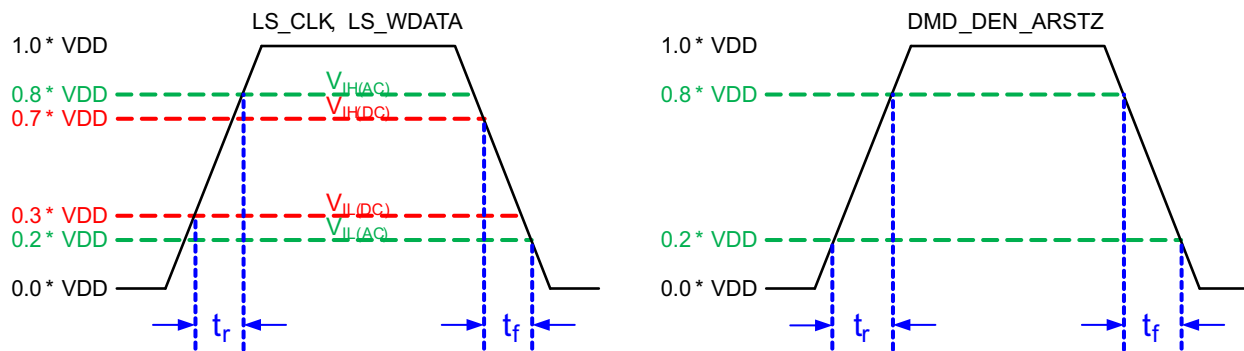
- (1) Specification is for LS\_CLK and LS\_WDATA pins. Refer to LPSDR input rise slew rate and fall slew rate in [Figure 6-3](#).
- (2) Specification is for DMD\_DEN\_ARSTZ pin. Refer to LPSDR input rise and fall slew rate in [Figure 6-3](#).
- (3) Window time derating example: 0.5-V/ns slew rate increases the window time by 0.7 ns, from 3 to 3.7 ns.

(4) Specification is for SubLVDS receiver time only and does not take into account commanding and latency after commanding.



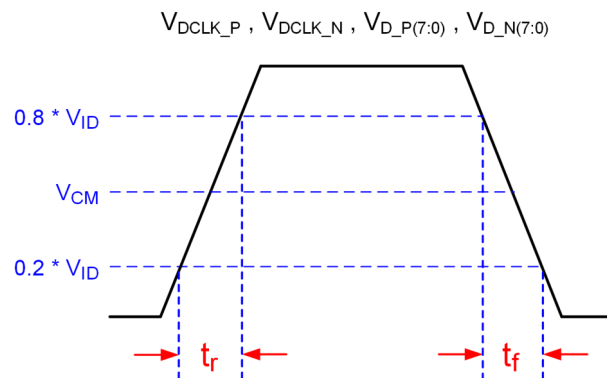
Low-speed interface is LPSDR and adheres to the [Section 6.6](#) and AC/DC Operating Conditions table in JEDEC Standard No. 209B, *Low Power Double Data Rate (LPDDR) JESD209B*.

**Figure 6-2. LPSDR Switching Parameters**

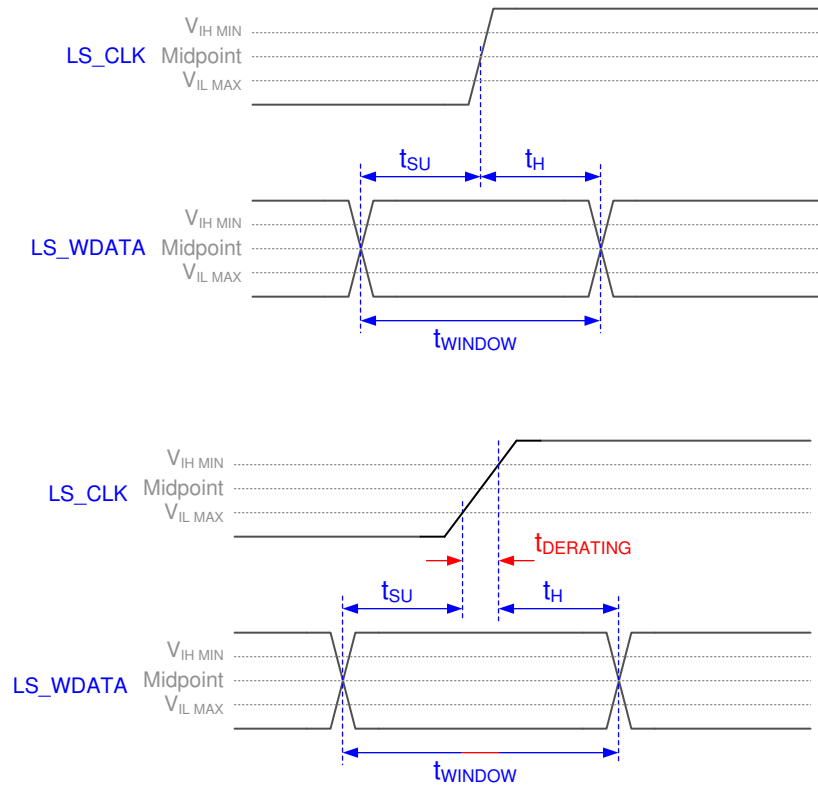


**Figure 6-3. LPSDR Input Rise and Fall Slew Rate**

Not to Scale

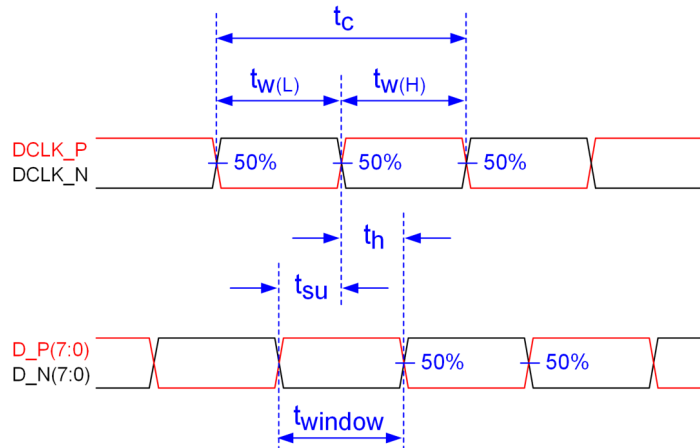


**Figure 6-4. SubLVDS Input Rise and Fall Slew Rate**

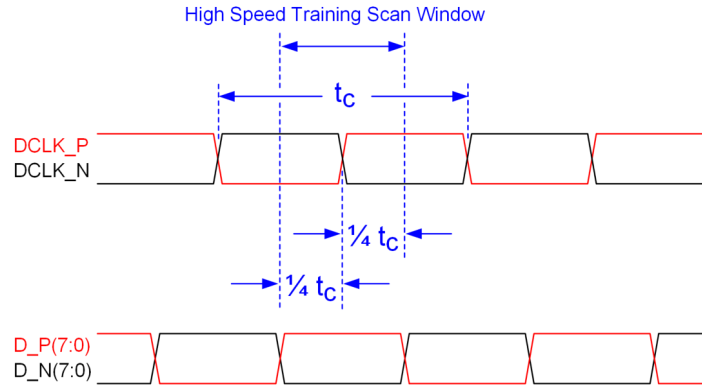


**Figure 6-5. Window Time Derating Concept**

Not to Scale

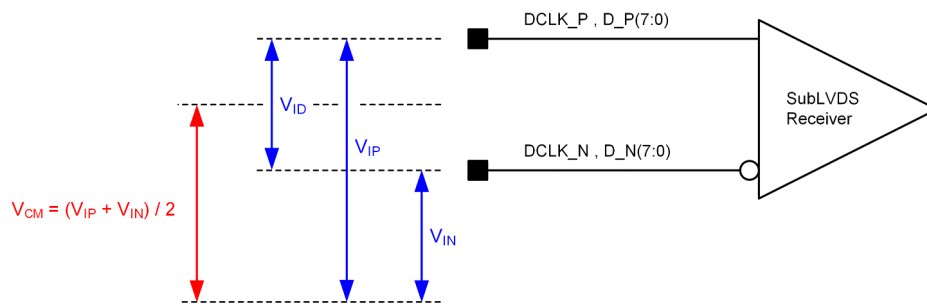


**Figure 6-6. SubLVDS Switching Parameters**

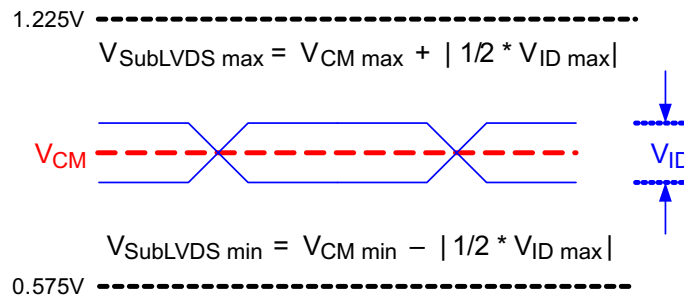


Note: Refer to [Section 7.3.3](#) for details.

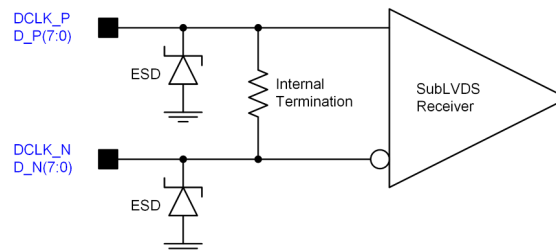
**Figure 6-7. High-Speed Training Scan Window**



**Figure 6-8. SubLVDS Voltage Parameters**



**Figure 6-9. SubLVDS Waveform Parameters**



**Figure 6-10. SubLVDS Equivalent Input Circuit**

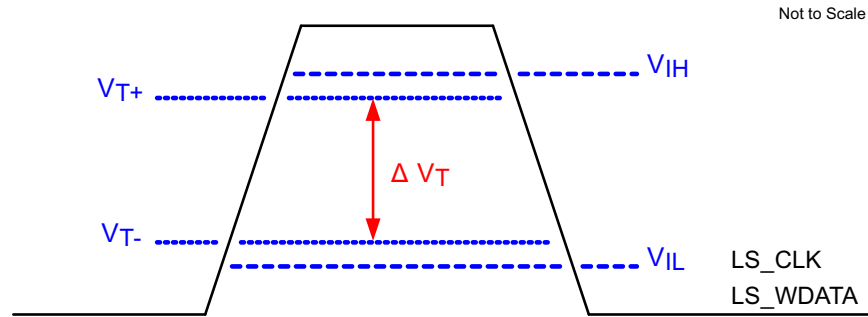


Figure 6-11. LPSDR Input Hysteresis

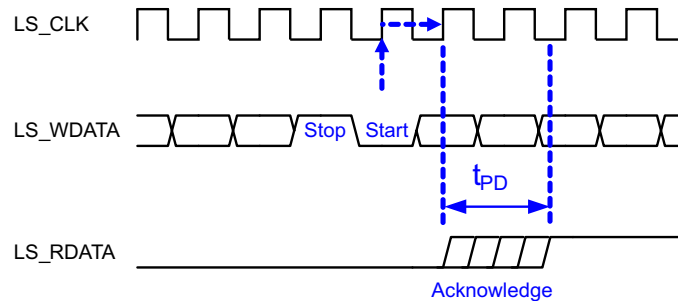
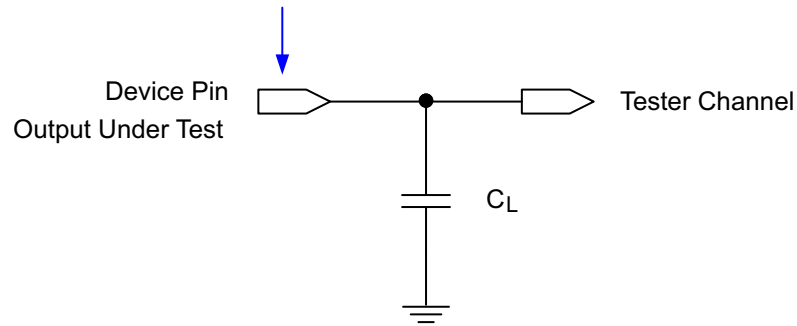


Figure 6-12. LPSDR Read Out

Data Sheet Timing Reference Point



See [Section 7.3.4](#) for more information.

Figure 6-13. Test Load Circuit for Output Propagation Measurement

## 6.8 Switching Characteristics<sup>(1)</sup>

Over operating free-air temperature range (unless otherwise noted).

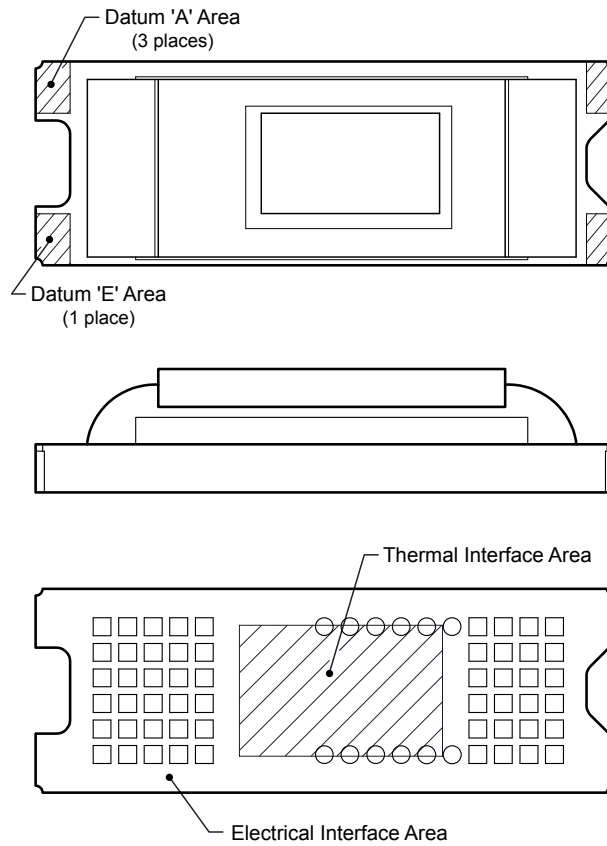
PARAMETER	TEST CONDITIONS	MIN	TYP	MAX	UNIT
$t_{PD}$	$C_L = 5 \text{ pF}$			11.1	ns
	$C_L = 10 \text{ pF}$			11.3	ns
	$C_L = 85 \text{ pF}$			15	ns
Slew rate, LS_RDATA		0.5			V/ns
Output duty cycle distortion, LS_RDATA		40%		60%	

(1) Device electrical characteristics comply with the values in [Section 6.4](#) unless otherwise noted.

### 6.9 System Mounting Interface Loads

PARAMETER	MIN	NOM	MAX	UNIT
Maximum system mounting interface load to be applied to the:				
• Thermal interface area <sup>(1)</sup>			45	N
• Clamping and electrical interface area <sup>(1)</sup>			100	N

(1) Uniformly distributed within area shown in Figure 6-14.



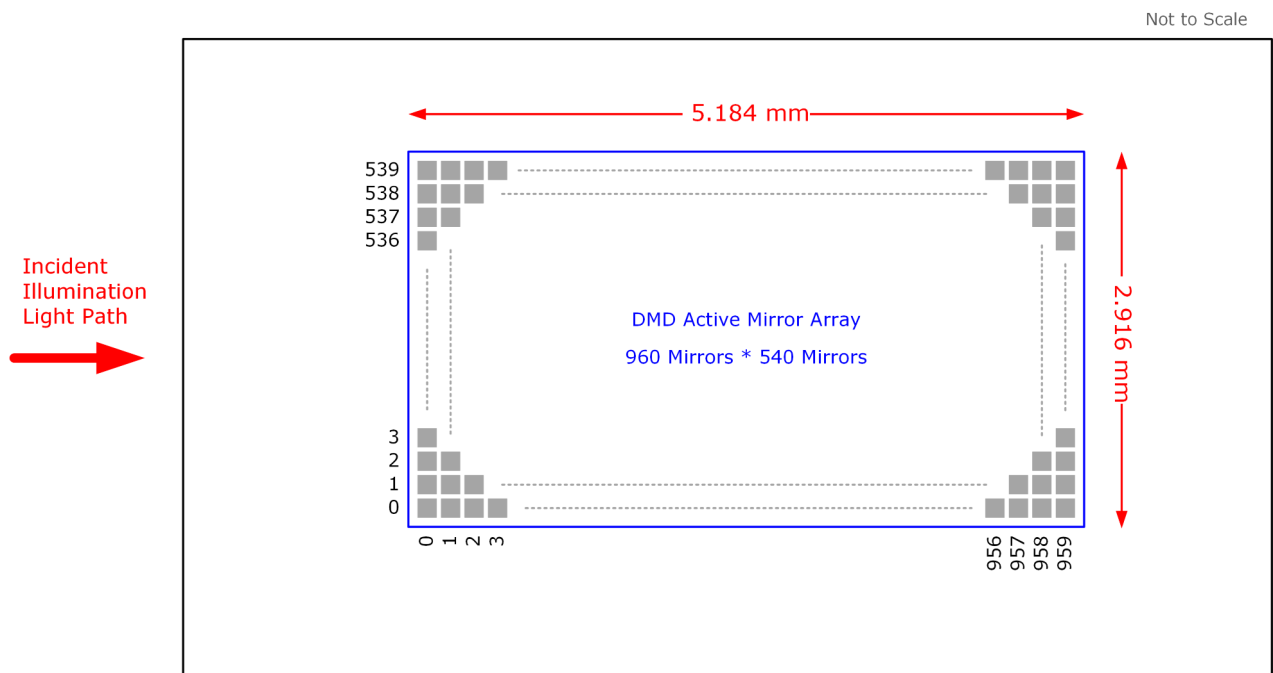
**Figure 6-14. System Interface Loads**



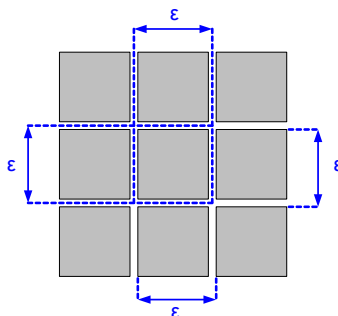
### 6.10 Micromirror Array Physical Characteristics

PARAMETER		VALUE	UNIT
Number of active columns <sup>(1)</sup>	See Figure 6-15	960	micromirrors
Number of active rows <sup>(1)</sup>	See Figure 6-15	540	micromirrors
$\epsilon$ Micromirror (pixel) pitch	See Figure 6-16	5.4	$\mu\text{m}$
Micromirror active array width	Micromirror pitch $\times$ number of active columns; see Figure 6-15	5.184	mm
Micromirror active array height	Micromirror pitch $\times$ number of active rows; see Figure 6-15	2.916	mm
Micromirror active border	Pond of micromirror (POM) <sup>(2)</sup>	20	micromirrors/side

- (1) The fast switching speed of the DMD micromirrors combined with advanced DLP image processing algorithms enables each micromirror to display two distinct pixels on the screen during every frame, resulting in a full 1280  $\times$  720 pixel image being displayed.
- (2) The structure and qualities of the border around the active array include a band of partially functional micromirrors called the POM. These micromirrors are structurally or electrically prevented from tilting toward the bright or ON state, but require an electrical bias to tilt toward OFF.



**Figure 6-15. Micromirror Array Physical Characteristics**

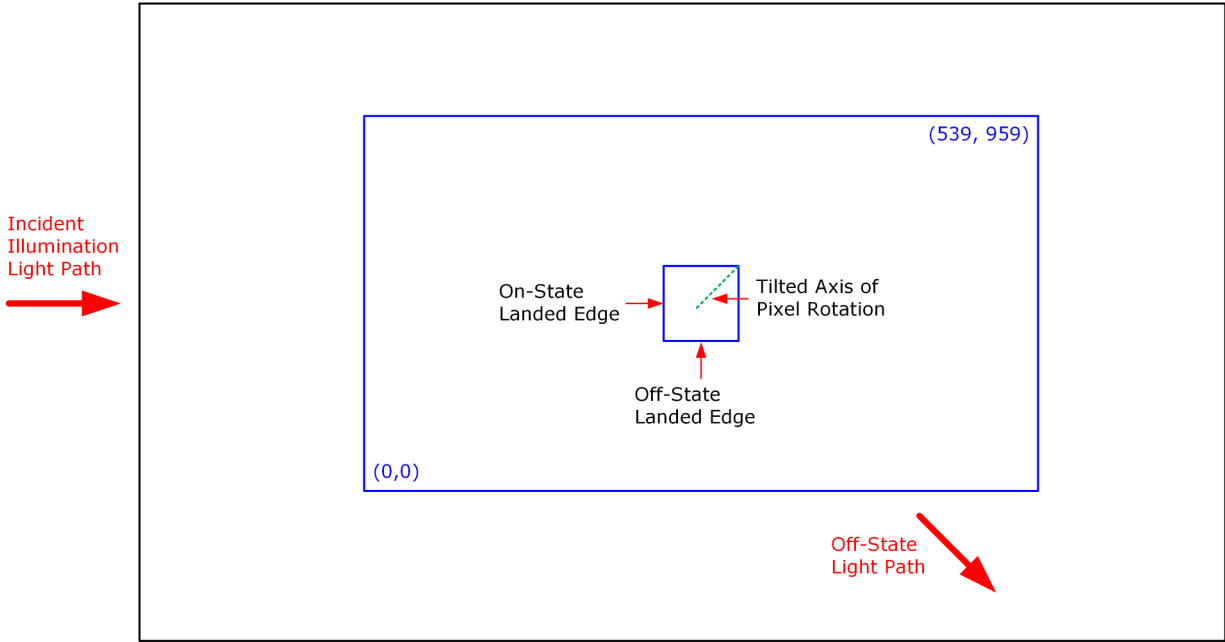


**Figure 6-16. Mirror (Pixel) Pitch**

## 6.11 Micromirror Array Optical Characteristics

PARAMETER		TEST CONDITIONS	MIN	NOM	MAX	UNIT
Micromirror tilt angle		DMD landed state <sup>(1)</sup>		17		°
Micromirror tilt angle tolerance <sup>(2) (3) (4) (5)</sup>			-1.4		1.4	°
Micromirror tilt direction <sup>(6) (7)</sup>		Landed ON state		180		°
		Landed OFF state		270		
Micromirror crossover time <sup>(8)</sup>		Typical performance		1	3	µs
Micromirror switching time <sup>(9)</sup>		Typical performance	10			
Image performance <sup>(10)</sup>	Bright pixel(s) in active area <sup>(11)</sup>	Gray 10 screen <sup>(12)</sup>			0	micromirrors
	Bright pixel(s) in the POM <sup>(13)</sup>	Gray 10 screen <sup>(12)</sup>			1	
	Dark pixel(s) in the active area <sup>(14)</sup>	White screen			4	
	Adjacent pixel(s) <sup>(15)</sup>	Any screen			0	
	Unstable pixel(s) in active area <sup>(16)</sup>	Any screen			0	

- (1) Measured relative to the plane formed by the overall micromirror array.
- (2) Additional variation exists between the micromirror array and the package datums.
- (3) Represents the landed tilt angle variation relative to the nominal landed tilt angle.
- (4) Represents the variation that can occur between any two individual micromirrors, located on the same device or located on different devices.
- (5) For some applications, it is critical to account for the micromirror tilt angle variation in the overall system optical design. With some system optical designs, the micromirror tilt angle variation within a device may result in perceivable non-uniformities in the light field reflected from the micromirror array. With some system optical designs, the micromirror tilt angle variation between devices may result in colorimetry variations, system efficiency variations or system contrast variations.
- (6) When the micromirror array is landed (not parked), the tilt direction of each individual micromirror is dictated by the binary contents of the CMOS memory cell associated with each individual micromirror. A binary value of 1 results in a micromirror landing in the ON state direction. A binary value of 0 results in a micromirror landing in the OFF state direction. See [Figure 6-17](#)
- (7) Micromirror tilt direction is measured as in a typical polar coordinate system: Measuring counter-clockwise from a 0° reference which is aligned with the +X Cartesian axis.
- (8) The time required for a micromirror to nominally transition from one landed state to the opposite landed state.
- (9) The minimum time between successive transitions of a micromirror
- (10) Conditions of Acceptance: All DMD image quality returns will be evaluated using the following projected image test conditions:  
 Test set degamma shall be linear  
 Test set brightness and contrast shall be set to nominal  
 The diagonal size of the projected image shall be a minimum of 20 inches  
 The projections screen shall be 1X gain  
 The projected image shall be inspected from a 38 inch minimum viewing distance  
 The image shall be in focus during all image quality tests
- (11) Bright pixel definition: A single pixel or mirror that is stuck in the ON position and is visibly brighter than the surrounding pixels
- (12) Gray 10 screen definition: All areas of the screen are colored with the following settings:  
 Red = 10/255  
 Green = 10/255  
 Blue = 10/255
- (13) POM definition: Rectangular border of off-state mirrors surrounding the active area
- (14) Dark pixel definition: A single pixel or mirror that is stuck in the OFF position and is visibly darker than the surrounding pixels
- (15) Adjacent pixel definition: Two or more stuck pixels sharing a common border or common point, also referred to as a cluster
- (16) Unstable pixel definition: A single pixel or mirror that does not operate in sequence with parameters loaded into memory. The unstable pixel appears to be flickering asynchronously with the image.



**Figure 6-17. Landed Pixel Orientation and Tilt**

## 6.12 Window Characteristics

PARAMETER <sup>(1)</sup>		MIN	NOM	MAX	UNIT
Window material designation		Corning Eagle XG			
Window refractive index	At wavelength 546.1 nm	1.5119			
Window aperture <sup>(2)</sup>					See <sup>(2)</sup>
Illumination overfill <sup>(3)</sup>					See <sup>(3)</sup>
Window transmittance, single-pass through both surfaces and glass	Minimum within the wavelength range 420 to 680 nm. Applies to all angles 0° to 30° AOI.	97%			
	Average over the wavelength range 420 to 680 nm. Applies to all angles 30° to 45° AOI.	97%			

(1) See [Section 7.5](#) for more information.

(2) See the package mechanical characteristics for details regarding the size and location of the window aperture.

(3) The active area of the DLP230KP device is surrounded by an aperture on the inside of the DMD window surface that masks structures of the DMD device assembly from normal view. The aperture is sized to anticipate several optical conditions. Overfill light illuminating the area outside the active array can scatter and create adverse effects to the performance of an end application using the DMD. The illumination optical system should be designed to limit light flux incident outside the active array to less than 10% of the average flux level in the active area. Depending on the particular system's optical architecture and assembly tolerances, the amount of overfill light on the outside of the active array may cause system performance degradation.

## 6.13 Chipset Component Usage Specification

### Note

TI assumes no responsibility for image quality artifacts or DMD failures caused by optical system operating conditions exceeding limits described previously.

The DLP230KP is a component of one or more DLP® chipsets. Reliable function and operation of the DLP230KP requires that it be used in conjunction with the other components of the applicable DLP chipset, including those components that contain or implement TI DMD control technology. TI DMD control technology consists of the TI technology and devices used for operating or controlling a DLP DMD.

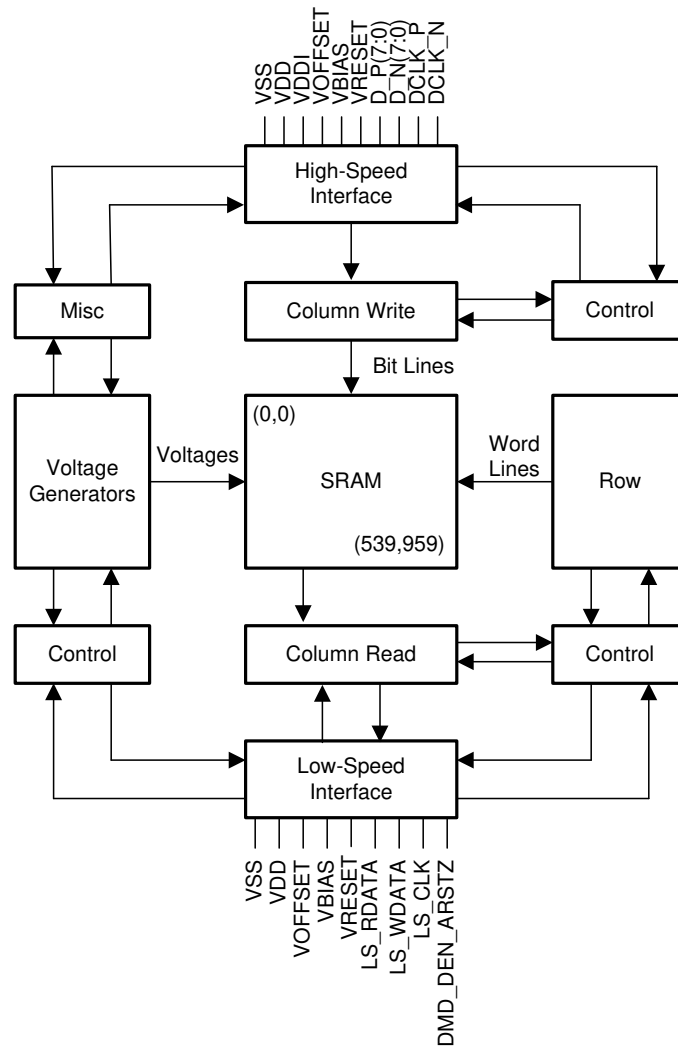
## 7 Detailed Description

### 7.1 Overview

The DLP230KP is a 0.23-inch diagonal spatial light modulator of aluminum micromirrors. Micromirror array size is 960 columns by 540 rows in a square micromirror arrangement. The fast switching speed of the DMD micromirrors combined with advanced DLP image processing algorithms enables each micromirror to display two distinct pixels on the screen during every frame, resulting in a full 1280 × 720 pixel image being displayed. The electrical interface is sub low voltage differential signaling (SubLVDS) data.

This chipset comprises this DMS and the DLPC3434 controller. The DLPA2000, DLP2005, and DLP3000 PMIC/LED drivers also support this chipset. To ensure reliable operation, the DLP230KP DMD must always be used with the DLPC3434 ZVB display controller and the DLPA2000, DLP2005, or DLP3000 PMIC/LED driver.

### 7.2 Functional Block Diagram



A. Details omitted for clarity.

## 7.3 Feature Description

### 7.3.1 Power Interface

The power management IC DLPA2000, DLPA2005, and DLPA3000 contain three regulated DC supplies for the DMD reset circuitry:  $V_{BIAS}$ ,  $V_{RESET}$  and  $V_{OFFSET}$ , as well as the two regulated DC supplies for the DLPC3434ZVB controller.

### 7.3.2 Low-Speed Interface

The low speed interface handles instructions that configure the DMD and control reset operation. LS\_CLK is the low-speed clock, and LS\_WDATA is the low speed data input.

### 7.3.3 High-Speed Interface

The purpose of the high-speed interface is to transfer pixel data rapidly and efficiently, making use of high speed DDR transfer and compression techniques to save power and time. The high-speed interface is composed of differential SubLVDS receivers for inputs with a dedicated clock.

### 7.3.4 Timing

The data sheet provides timing at the device pin. For output timing analysis, the tester pin electronics and its transmission line effects must be taken into account. [Figure 6-13](#) shows an equivalent test load circuit for the output under test. Timing reference loads are not intended as a precise representation of any particular system environment or depiction of the actual load presented by a production test. System designers should use IBIS or other simulation tools to correlate the timing reference load to a system environment. The load capacitance value stated is only for characterization and measurement of AC timing signals. This load capacitance value does not indicate the maximum load the device is capable of driving.

## 7.4 Device Functional Modes

The DLPC3434 controller manages the functional modes of the DMD. For more information, download the controller [data sheet](#) or contact a TI applications engineer.

## 7.5 Optical Interface and System Image Quality Considerations

TI assumes no responsibility for end-equipment optical performance. Achieving the desired end-equipment optical performance involves making trade-offs between numerous component and system design parameters. Optimizing system optical performance and image quality strongly relate to optical system design parameter trades. Although it is not possible to anticipate every conceivable application, projector image quality and optical performance is contingent on compliance to the optical system operating conditions described in the following sections.

### 7.5.1 Numerical Aperture and Stray Light Control

The angle defined by the numerical aperture of the illumination and projection optics at the DMD optical area should be the same. This angle should not exceed the nominal device mirror tilt angle unless appropriate apertures are added in the illumination and/or projection pupils to block out flat-state and stray light from the projection lens. The mirror tilt angle defines DMD capability to separate the ON optical path from any other light path, including undesirable flat-state specular reflections from the DMD window, DMD border structures, or other system surfaces near the DMD such as prism or lens surfaces. If the numerical aperture exceeds the mirror tilt angle, or if the projection numerical aperture angle is more than two degrees larger than the illumination numerical aperture angle, objectionable artifacts in the display's border and/or active area could occur.

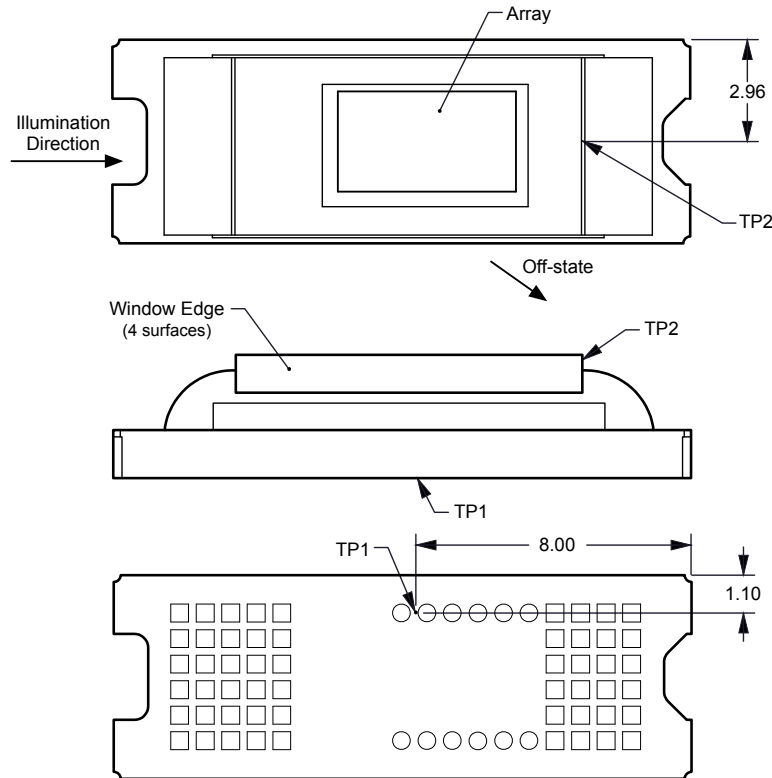
### 7.5.2 Pupil Match

TI's optical and image quality specifications assume that the exit pupil of the illumination optics is nominally centered within 2° of the entrance pupil of the projection optics. Misalignment of pupils can create objectionable artifacts in the display's border and/or active area, which may require additional system apertures to control, especially if the numerical aperture of the system exceeds the pixel tilt angle.

### 7.5.3 Illumination Overfill

The active area of the device is surrounded by an aperture on the inside DMD window surface that masks structures of the DMD chip assembly from normal view and is sized to anticipate several optical operating conditions. Overfill light illuminating the window aperture can create artifacts from the edge of the window aperture opening and other surface anomalies that may be visible on the screen. The illumination optical system should be designed to limit light flux incident anywhere on the window aperture from exceeding approximately 10% of the average flux level in the active area. Depending on the particular system's optical architecture, overfill light may have to be further reduced below the suggested 10% level in order to be acceptable.

### 7.6 Micromirror Array Temperature Calculation



**Figure 7-1. DMD Thermal Test Points**

Micromirror array temperature cannot be measured directly, therefore it must be computed analytically from measurement points on the outside of the package, the package thermal resistance, the electrical power, and the illumination heat load. The relationship between array temperature and the reference ceramic temperature (thermal test point TP1 in Figure 7-1) is provided by the following equations:

$$T_{\text{ARRAY}} = T_{\text{CERAMIC}} + (Q_{\text{ARRAY}} \times R_{\text{ARRAY-TO-CERAMIC}})$$

$$Q_{\text{ARRAY}} = Q_{\text{ELECTRICAL}} + Q_{\text{ILLUMINATION}}$$

$$Q_{\text{ILLUMINATION}} = (C_{\text{L2W}} \times \text{SL})$$

where

- $T_{\text{ARRAY}}$  = Computed DMD array temperature ( $^{\circ}\text{C}$ )
- $T_{\text{CERAMIC}}$  = Measured ceramic temperature ( $^{\circ}\text{C}$ ), TP1 location in [Figure 7-1](#)
- $R_{\text{ARRAY-TO-CERAMIC}}$  = Thermal resistance from array to TP1 on ceramic ( $^{\circ}\text{C}/\text{W}$ ) specified in [Section 6.5](#)
- $Q_{\text{ARRAY}}$  = Total (electrical + absorbed) DMD power on array (W)
- $Q_{\text{ELECTRICAL}}$  = Nominal DMD electrical power dissipation (W)
- $C_{\text{L2W}}$  = Conversion constant for screen lumens to absorbed optical power on the DMD (W/lm) specified below
- $\text{SL}$  = Measured ANSI screen lumens (lm)

Electrical power dissipation of the DMD is variable and depends on the voltages, data rates, and operating frequencies. Nominal electrical power dissipation to use when calculating array temperature is 0.17 W. Absorbed optical power from the illumination source is variable and depends on the operating state of the micromirrors and the intensity of the light source. Equations shown above are valid for a 1-chip DMD system with total projection efficiency through the projection lens from DMD to the screen of 87%.

The conversion constant  $C_{\text{L2W}}$  is based on the DMD micromirror array characteristics. It assumes a spectral efficiency of 300 lm/W for the projected light and illumination distribution of 83.7% on the DMD active array, and 16.3% on the DMD array border and window aperture. The conversion constant is calculated to be 0.00266 W/lm.

Sample calculations for typical projection application:

$$T_{\text{CERAMIC}} = 55^{\circ}\text{C} \text{ (measured)}$$

$$\text{SL} = 200 \text{ lm (measured)}$$

$$Q_{\text{ELECTRICAL}} = 0.17 \text{ W}$$

$$C_{\text{L2W}} = 0.00266 \text{ W/lm}$$

$$Q_{\text{ARRAY}} = 0.17 \text{ W} + (0.00266 \text{ W/lm} \times 200 \text{ lm}) = 0.702 \text{ W}$$

$$T_{\text{ARRAY}} = 55^{\circ}\text{C} + (0.702 \text{ W} \times 9^{\circ}\text{C/W}) = 61.32^{\circ}\text{C}$$

## 7.7 Micromirror Landed-On/Landed-Off Duty Cycle

### 7.7.1 Definition of Micromirror Landed-On/Landed-Off Duty Cycle

The micromirror landed-on/landed-off duty cycle (landed duty cycle) denotes the amount of time (as a percentage) that an individual micromirror is landed in the ON state versus the amount of time the same micromirror is landed in the OFF state.

As an example, a landed duty cycle of 75/25 indicates that the referenced pixel is in the ON state 75% of the time and in the OFF state 25% of the time, whereas 25/75 would indicate that the pixel is in the ON state 25% of the time. Likewise, 50/50 indicates that the pixel is ON 50% of the time and OFF 50% of the time.

Note that when assessing landed duty cycle, the time spent switching from one state (ON or OFF) to the other state (OFF or ON) is considered negligible and is thus ignored.

Since a micromirror can only be landed in one state or the other (ON or OFF), the two numbers (percentages) nominally add to 100.

### 7.7.2 Landed Duty Cycle and Useful Life of the DMD

Knowing the long-term average landed duty cycle (of the end product or application) is important because subjecting all (or a portion) of the DMD's micromirror array to an asymmetric landed duty cycle for a prolonged period of time can reduce the DMD's usable life.

Note that it is the symmetry/asymmetry of the landed duty cycle that is of relevance. The symmetry of the landed duty cycle is determined by how close the two numbers (percentages) are to being equal. For example, a landed duty cycle of 50/50 is perfectly symmetrical whereas a landed duty cycle of 100/0 or 0/100 is perfectly asymmetrical.



### 7.7.3 Landed Duty Cycle and Operational DMD Temperature

Operational DMD temperature and landed duty cycle interact to affect the DMD's usable life. This is quantified in the de-rating curve shown in [Figure 6-1](#). The importance of this curve is that:

- All points along this curve represent the same usable life.
- All points above this curve represent lower usable life (and the further away from the curve, the lower the usable life).
- All points below this curve represent higher usable life (and the further away from the curve, the higher the usable life).

In practice, this curve specifies the maximum operating DMD temperature that the DMD should be operated at for a given long-term average landed duty cycle.

### 7.7.4 Estimating the Long-Term Average Landed Duty Cycle of a Product or Application

During a given period of time, the nominal landed duty cycle of a given pixel is determined by the image content being displayed by that pixel.

For example, in the simplest case, when displaying pure-white on a given pixel for a given time period, that pixel will experience very close to a 100/0 landed duty cycle during that time period. Likewise, when displaying pure-black, the pixel will experience very close to a 0/100 landed duty cycle.

Between the two extremes (ignoring for the moment color and any image processing that may be applied to an incoming image), the landed duty cycle tracks one-to-one with the gray scale value, as shown in [Table 7-1](#).

**Table 7-1. Grayscale Value and Landed Duty Cycle**

Grayscale Value	Nominal Landed Duty Cycle
0%	0/100
10%	10/90
20%	20/80
30%	30/70
40%	40/60
50%	50/50
60%	60/40
70%	70/30
80%	80/20
90%	90/10
100%	100/0

Accounting for color rendition (but still ignoring image processing) requires knowing both the color scale value (from 0% to 100%) for each constituent primary color (red, green, and/or blue) for the given pixel as well as the color cycle time for each primary color, where "color cycle time" is the total percentage of the frame time that a given primary must be displayed in order to achieve the desired white point.

During a given period of time, the nominal landed duty cycle of a given pixel can be calculated as follows:

$$\text{Landed Duty Cycle} = (\text{Red\_Cycle\_}\% \times \text{Red\_Scale\_Value}) + (\text{Green\_Cycle\_}\% \times \text{Green\_Scale\_Value}) + (\text{Blue\_Cycle\_}\% \times \text{Blue\_Scale\_Value}) \quad (1)$$

where

Red\_Cycle\_%, Green\_Cycle\_%, and Blue\_Cycle\_% represent the percentage of the frame time that red, green, and blue are displayed (respectively) to achieve the desired white point.

For example, assuming that the red, green and blue color cycle times are 50%, 20%, and 30% respectively (in order to achieve the desired white point), then the nominal landed duty cycle for various combinations of red, green, blue color intensities would be as shown in [Table 7-2](#).

**Table 7-2. Example Landed Duty Cycle for Full-Color Pixels**

Red Cycle Percentage	Green Cycle Percentage	Blue Cycle Percentage
50%	20%	30%

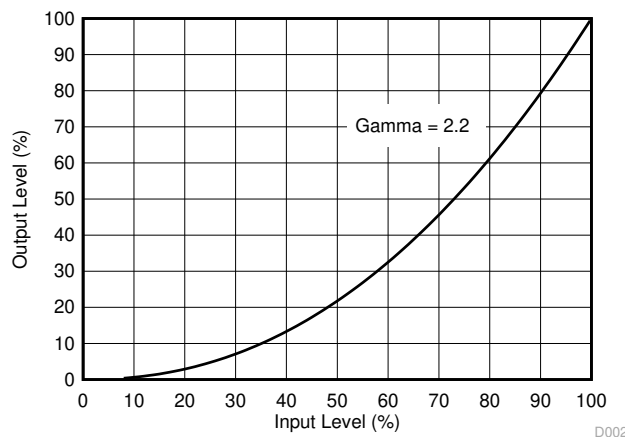
  

Red Scale Value	Green Scale Value	Blue Scale Value	Nominal Landed Duty Cycle
0%	0%	0%	0/100
100%	0%	0%	50/50
0%	100%	0%	20/80
0%	0%	100%	30/70
12%	0%	0%	6/94
0%	35%	0%	7/93
0%	0%	60%	18/82
100%	100%	0%	70/30
0%	100%	100%	50/50
100%	0%	100%	80/20
12%	35%	0%	13/87
0%	35%	60%	25/75
12%	0%	60%	24/76
100%	100%	100%	100/0

The last factor to account for in estimating the landed duty cycle is any applied image processing. Within the DLP controller DLPC3434ZVB, the three functions which influence the actual landed duty cycle are gamma, IntelliBright™, and bitplane sequencing rules.

Gamma is a power function of the form  $Output\_Level = A \times Input\_Level^{Gamma}$ , where A is a scaling factor that is typically set to 1.

In the DLPC3434ZVB controller, gamma is applied to the incoming image data on a pixel-by-pixel basis. A typical gamma factor is 2.2, which transforms the incoming data as shown in [Figure 7-2](#).



**Figure 7-2. Example of Gamma = 2.2**

For example, from [Figure 7-2](#), if the gray scale value of a given input pixel is 40% (before gamma is applied), then the gray scale value is 13% after gamma is applied. This reduction indicates that gamma has a direct impact on the displayed gray scale level of a pixel, and it also has a direct impact on the landed duty cycle of a pixel.

The IntelliBright algorithm for content adaptive illumination control (CAIC) and local area brightness boost (LABB) also apply transform functions on the gray scale level of each pixel.

But while the amount of gamma applied to every pixel of every frame is constant (the exponent, gamma, is constant), CAIC and LABB are both adaptive functions that can apply different amounts of either boost or compression to every pixel of every frame.

Give consideration to any image processing which occurs before the DLPC3434 controller.

## 8 Application and Implementation

---

### Note

Information in the following applications sections is not part of the TI component specification, and TI does not warrant its accuracy or completeness. TI's customers are responsible for determining suitability of components for their purposes, as well as validating and testing their design implementation to confirm system functionality.

---

### 8.1 Application Information

The DMDs are spatial light modulators which reflect incoming light from an illumination source to one of two directions, with the primary direction being into a projection or collection optic. Each application is derived primarily from the optical architecture of the system and the format of the data coming into the DLPC3434 controller. The new high tilt pixel in the side-illuminated DMD increases brightness performance and enables a smaller system footprint for thickness-constrained applications. Applications of interest include projection technology embedded in display devices such as ultra low-power battery operated mobile accessory projectors, phones, tablets, ultra mobile low end smart TVs, and virtual assistants.

The PMIC/LED driver strictly controls the DMD power-up and power-down sequencing. Refer to [Section 9](#) for power-up and power-down specifications. To ensure reliable operation, the DLP230KP DMD must always be used with the DLPC3434 display controller and either the DLPA2000, DLPA2005, or DLPA3000 PMIC/LED driver.

## 8.2 Typical Application

A common application when using a DLP230KP DMD and a DLPC3434 is for creating a Pico projector that can be used as an accessory to a smartphone, tablet, or a laptop. The DLPC3434 controller in the Pico projector receives images from a multimedia front end within the product as shown in Figure 8-1.

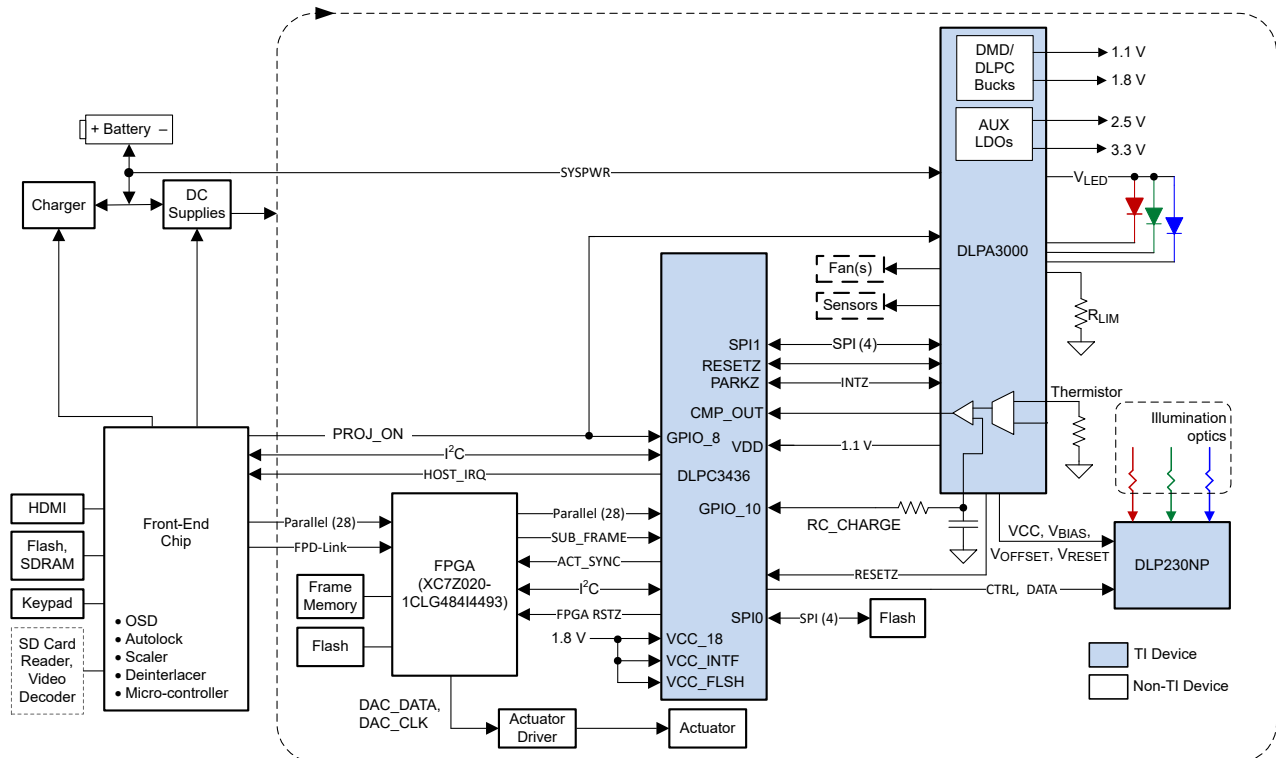


Figure 8-1. Typical Application Diagram

### 8.2.1 Design Requirements

A pico projector is created by using a DLP chipset comprised of a DLP230KP DMD, a DLPC3434 controller, and a DLPA2000/2005/3000 PMIC/LED driver. The DLPC3434 controller performs the digital image processing, the DLPA2000/2005/3000 provides the needed analog functions for the projector, and the DLP230KP DMD is the display device for producing the projected image.

In addition to the three DLP chips in the chipset, other chips are needed. At a minimum a flash part is needed to store the DLPC3434 controller software.

The illumination light that is applied to the DMD is typically from red, green, and blue LEDs. These are often contained in three separate packages, but sometimes more than one color of LED die may be in the same package to reduce the overall size of the pico projector.

The DLPC3434 controller receives image data from the multimedia front end over a 24-bit parallel interface. An I<sup>2</sup>C interface should be connected from the multimedia front end for sending commands to the DLPC3434 controller for configuring the chipset for different features.

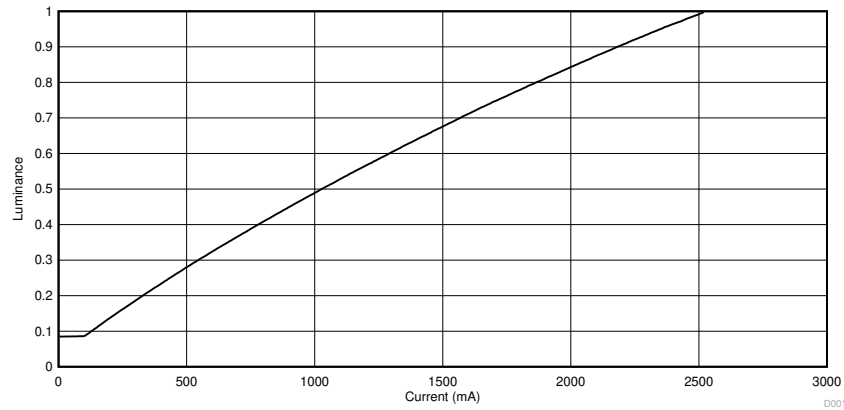
### 8.2.2 Detailed Design Procedure

For connecting together the DLPC3434 controller, the DLPA2000/2005/3000, and the DLP230KP DMD, see the reference design schematic. When a circuit board layout is created from this schematic a very small circuit board is possible. An example small board layout is included in the reference design data base. Layout guidelines should be followed to achieve a reliable projector.

The optical engine that has the LED packages and the DMD mounted to it is typically supplied by an optical OEM who specializes in designing optics for DLP projectors.

### 8.2.3 Application Curve

As the LED currents that are driven time-sequentially through the red, green, and blue LEDs are increased, the brightness of the projector increases. This increase is somewhat non-linear, and the curve for typical white screen lumens changes with LED currents is as shown in Figure 8-2. For the LED currents shown, it is assumed that the same current amplitude is applied to the red, green, and blue LEDs.



**Figure 8-2. Luminance vs LED Current**

## 9 Power Supply Recommendations

The following power supplies are all required to operate the DMD:  $V_{DD}$ ,  $V_{DDI}$ ,  $V_{OFFSET}$ ,  $V_{BIAS}$ , and  $V_{RESET}$ . All  $V_{SS}$  connections are also required. DMD power-up and power-down sequencing is strictly controlled by the DLPA2000/2005/3000 devices.

### CAUTION

For reliable operation of the DMD, the following power supply sequencing requirements must be followed. Failure to adhere to the prescribed power-up and power-down procedures may affect device reliability.

$V_{DD}$ ,  $V_{DDI}$ ,  $V_{OFFSET}$ ,  $V_{BIAS}$ , and  $V_{RESET}$  power supplies have to be coordinated during power-up and power-down operations. Failure to meet any of the specified requirements results in a significant reduction in the DMD reliability and lifetime. Refer to [Figure 9-2](#).  $V_{SS}$  must also be connected.

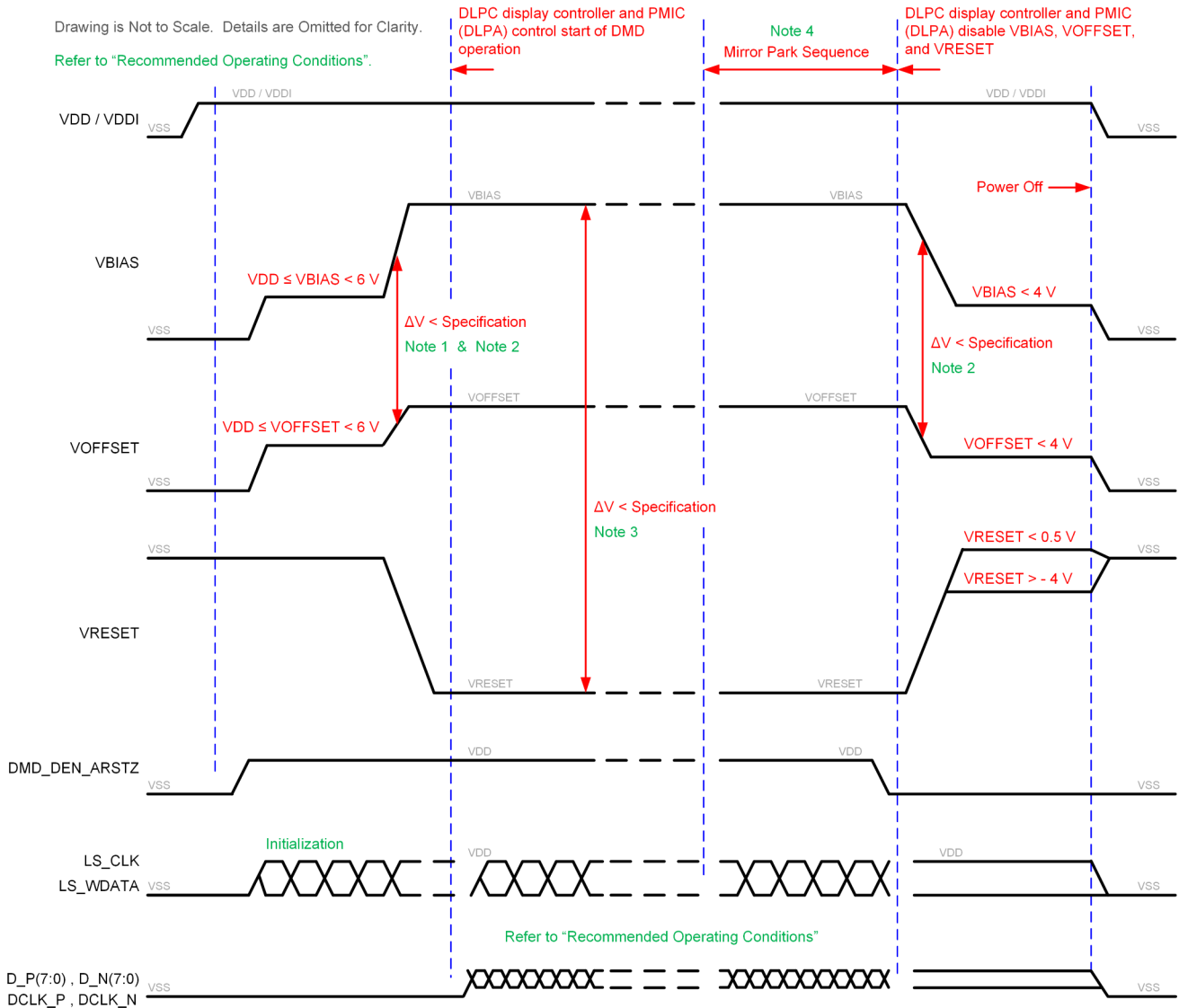
### 9.1 Power Supply Power-Up Procedure

- During power-up,  $V_{DD}$  and  $V_{DDI}$  must always start and settle before  $V_{OFFSET}$ ,  $V_{BIAS}$ , and  $V_{RESET}$  voltages are applied to the DMD.
- During power-up, it is a strict requirement that the delta between  $V_{BIAS}$  and  $V_{OFFSET}$  must be within the specified limit shown in [Section 6.4](#). Refer to [Figure 9-2](#) for power-up delay requirements.
- During power-up, the DMD's LPSDR input pins shall not be driven high until after  $V_{DD}$  and  $V_{DDI}$  have settled at operating voltage.
- During power-up, there is no requirement for the relative timing of  $V_{RESET}$  with respect to  $V_{OFFSET}$  and  $V_{BIAS}$ . Power supply slew rates during power-up are flexible, provided that the transient voltage levels follow the requirements listed previously and in [Figure 9-1](#).

### 9.2 Power Supply Power-Down Procedure

- The power-down sequence is the reverse order of the previous power-up sequence.  $V_{DD}$  and  $V_{DDI}$  must be supplied until after  $V_{BIAS}$ ,  $V_{RESET}$ , and  $V_{OFFSET}$  are discharged to within 4 V of ground.
- During power-down, it is not mandatory to stop driving  $V_{BIAS}$  prior to  $V_{OFFSET}$ , but it is a strict requirement that the delta between  $V_{BIAS}$  and  $V_{OFFSET}$  must be within the specified limit shown in [Section 6.4](#) (Refer to Note 2 for [Figure 9-1](#)).
- During power-down, the DMD's LPSDR input pins must be less than  $V_{DDI}$ , the specified limit shown in [Section 6.4](#).
- During power-down, there is no requirement for the relative timing of  $V_{RESET}$  with respect to  $V_{OFFSET}$  and  $V_{BIAS}$ .
- Power supply slew rates during power-down are flexible, provided that the transient voltage levels follow the requirements listed previously and in [Figure 9-1](#).

### 9.3 Power Supply Sequencing Requirements



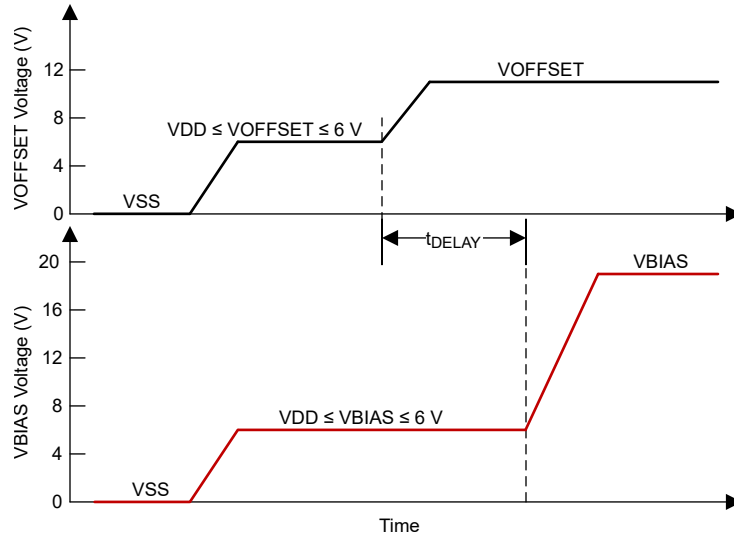
- A. Refer to [Table 9-1](#) and [Figure 9-2](#) for critical power-up sequence delay requirements.
- B. To prevent excess current, the supply voltage delta  $|V_{BIAS} - V_{OFFSET}|$  must be less than specified in [Section 6.4](#). OEMs may find that the most reliable way to ensure this is to power  $V_{OFFSET}$  prior to  $V_{BIAS}$  during power-up and to remove  $V_{BIAS}$  prior to  $V_{OFFSET}$  during power-down. Refer to [Table 9-1](#) and [Figure 9-2](#) for power-up delay requirements.
- C. To prevent excess current, the supply voltage delta  $|V_{BIAS} - V_{RESET}|$  must be less than the specified limit shown in [Section 6.4](#).
- D. When system power is interrupted, the DLPA2000/2005/3000 initiates hardware power-down that disables  $V_{BIAS}$ ,  $V_{RESET}$  and  $V_{OFFSET}$  after the micromirror park sequence.
- E. Drawing is not to scale and details are omitted for clarity.

**Figure 9-1. Power Supply Sequencing Requirements (Power Up and Power Down)**



**Table 9-1. Power-Up Sequence Delay Requirement**

PARAMETER		MIN	MAX	UNIT
$t_{\text{DELAY}}$	Delay requirement from $V_{\text{OFFSET}}$ power up to $V_{\text{BIAS}}$ power up	2		ms
$V_{\text{OFFSET}}$	Supply voltage level at beginning of power-up sequence delay (see Figure 9-2)		6	V
$V_{\text{BIAS}}$	Supply voltage level at end of power-up sequence delay (see Figure 9-2)		6	V



Refer to Table 9-1 for  $V_{\text{OFFSET}}$  and  $V_{\text{BIAS}}$  supply voltage levels during power-up sequence delay.

**Figure 9-2. Power-Up Sequence Delay Requirement**

## 10 Layout

### 10.1 Layout Guidelines

The DLP230KP DMD connects to a PCB or a flex circuit using an interposer. For additional layout guidelines regarding length matching, and impedance, see the DLPC3434 controller datasheet. For a detailed layout example refer to the layout design files. Some layout guidelines for routing to the DMD are:

- Match lengths for the LS\_WDATA and LS\_CLK signals.
- Minimize vias, layer changes, and turns for the HS bus signals. Refer to [Figure 10-1](#).
- Minimum of two 100-nF (25 V) capacitors - one close to  $V_{BIAS}$  pin. Capacitors C4 and C8 in [Figure 10-1](#).
- Minimum of two 100-nF (25 V) capacitors - one close to each  $V_{RST}$  pin. Capacitors C3 and C7 in [Figure 10-1](#).
- Minimum of two 220-nF (25 V) capacitors - one close to each  $V_{OFS}$  pin. Capacitors C5 and C6 in [Figure 10-1](#).
- Minimum of four 100-nF (6.3 V) capacitors - two close to each side of the DMD. Capacitors C1, C2, C9 and C10 in [Figure 10-1](#).

### 10.2 Layout Example

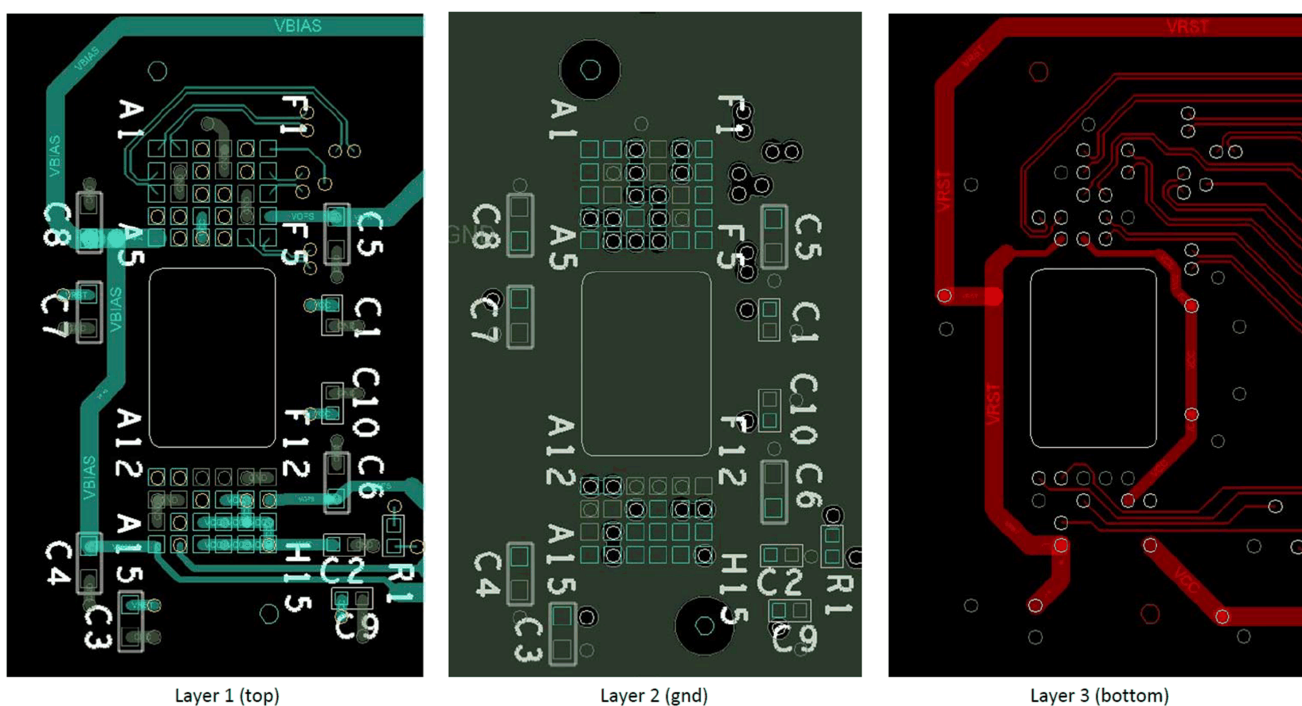


Figure 10-1. Power Supply Connections

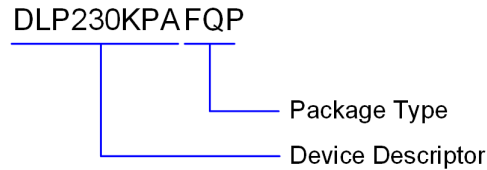
## 11 Device and Documentation Support

### 11.1 Device Support

#### 11.1.1 Third-Party Products Disclaimer

TI'S PUBLICATION OF INFORMATION REGARDING THIRD-PARTY PRODUCTS OR SERVICES DOES NOT CONSTITUTE AN ENDORSEMENT REGARDING THE SUITABILITY OF SUCH PRODUCTS OR SERVICES OR A WARRANTY, REPRESENTATION OR ENDORSEMENT OF SUCH PRODUCTS OR SERVICES, EITHER ALONE OR IN COMBINATION WITH ANY TI PRODUCT OR SERVICE.

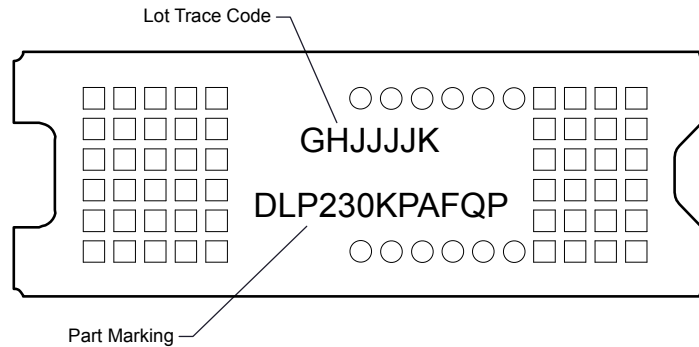
#### 11.1.2 Device Nomenclature



**Figure 11-1. Part Number Description**

#### 11.1.3 Device Markings

The device marking includes the legible character string GHJJJK. DLP230KPAFQP is the device marking.



**Figure 11-2. DMD Marking**

## 11.2 Chipset Resources

The table below lists quick access links. Categories include technical documents, support and community resources, tools and software, and quick access to sample or buy.

**Table 11-1. Chipset Resources**

Chipset Devices	Product folder	Ordering & quality	Technical documents	Design & development	Support & training
DLP230KP	<a href="#">Click here</a>	<a href="#">Click here</a>	<a href="#">Click here</a>	<a href="#">Click here</a>	<a href="#">Click here</a>
DLPC3434	<a href="#">Click here</a>	<a href="#">Click here</a>	<a href="#">Click here</a>	<a href="#">Click here</a>	<a href="#">Click here</a>
DLPA3000	<a href="#">Click here</a>	<a href="#">Click here</a>	<a href="#">Click here</a>	<a href="#">Click here</a>	<a href="#">Click here</a>
DLPA2000	<a href="#">Click here</a>	<a href="#">Click here</a>	<a href="#">Click here</a>	<a href="#">Click here</a>	<a href="#">Click here</a>
DLPA2005	<a href="#">Click here</a>	<a href="#">Click here</a>	<a href="#">Click here</a>	<a href="#">Click here</a>	<a href="#">Click here</a>

### 11.3 Receiving Notification of Documentation Updates

To receive notification of documentation updates, navigate to the device product folder on [ti.com](http://ti.com). Click on *Subscribe to updates* to register and receive a weekly digest of any product information that has changed. For change details, review the revision history included in any revised document.

## 11.4 Support Resources

[TI E2E™ support forums](#) are an engineer's go-to source for fast, verified answers and design help — straight from the experts. Search existing answers or ask your own question to get the quick design help you need.

Linked content is provided "AS IS" by the respective contributors. They do not constitute TI specifications and do not necessarily reflect TI's views; see TI's [Terms of Use](#).

## 11.5 Trademarks

Pico™ and TI E2E™ are trademarks of Texas Instruments.

IntelliBright™ is a trademark of Texas Instruments.

DLP® is a registered trademark of Texas Instruments.

is a registered trademark of TI.

All trademarks are the property of their respective owners.

## 11.6 Electrostatic Discharge Caution



This integrated circuit can be damaged by ESD. Texas Instruments recommends that all integrated circuits be handled with appropriate precautions. Failure to observe proper handling and installation procedures can cause damage.

ESD damage can range from subtle performance degradation to complete device failure. Precision integrated circuits may be more susceptible to damage because very small parametric changes could cause the device not to meet its published specifications.

## 11.7 Glossary

[TI Glossary](#) This glossary lists and explains terms, acronyms, and definitions.

## 12 Mechanical, Packaging, and Orderable Information

The following pages include mechanical, packaging, and orderable information. This information is the most current data available for the designated devices. This data is subject to change without notice and revision of this document. For browser-based versions of this data sheet, refer to the left-hand navigation.

## 12.1 Package Option Addendum

### 12.1.1 Packaging Information

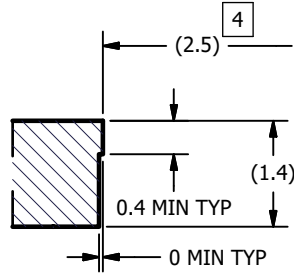
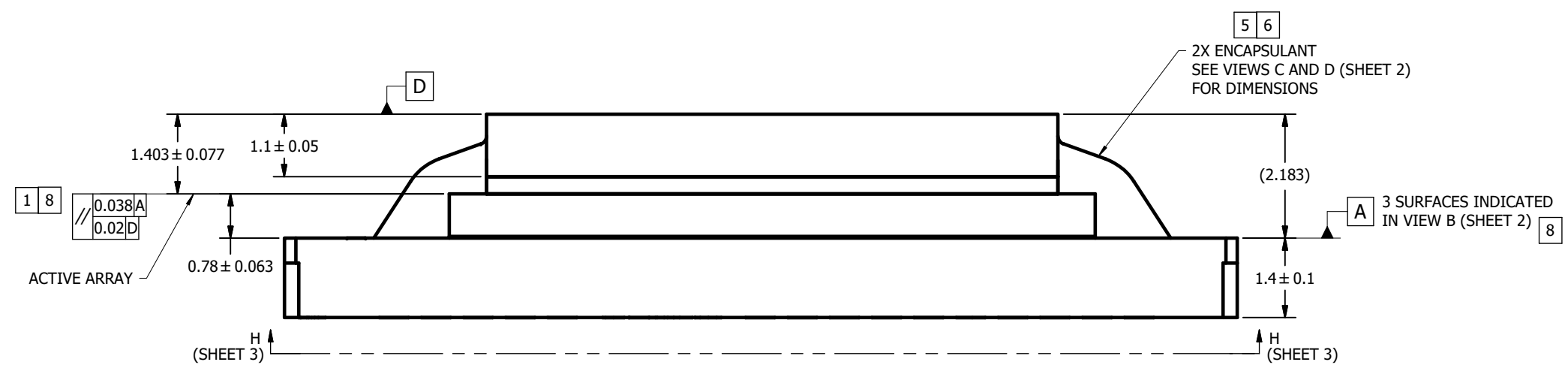
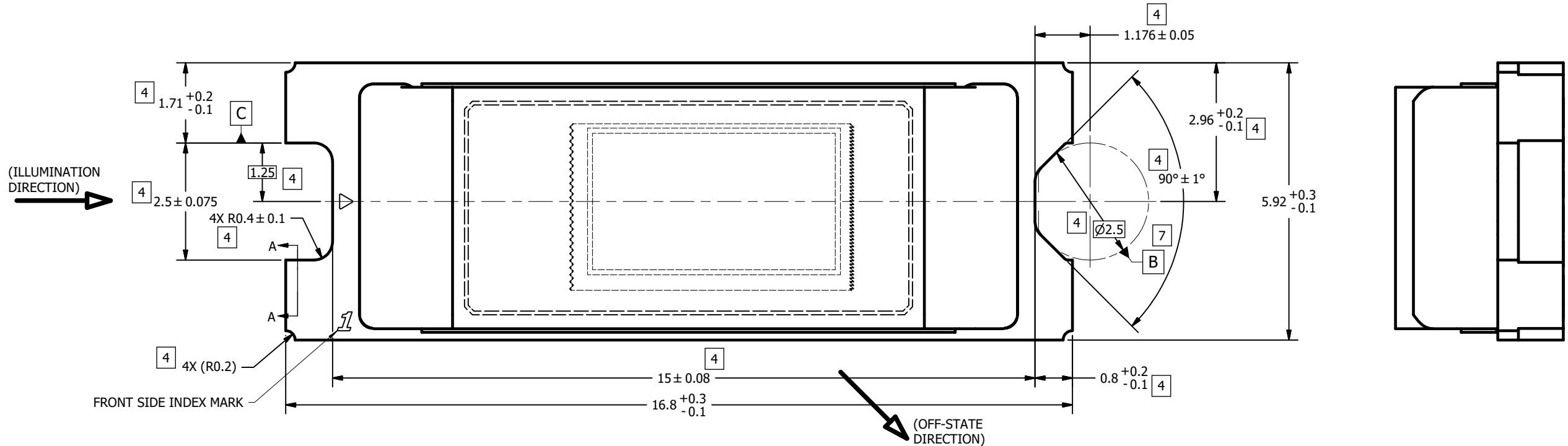
Orderable Device	Status <sup>(1)</sup>	Package Type	Package Drawing	Pins	Package Qty	Eco Plan <sup>(2)</sup>	Lead/Ball Finish	MSL Peak Temp <sup>(3)</sup>	Op Temp (°C)	Device Marking <sup>(4)</sup> <sup>(5)</sup>
DLP230KPAFQP	ACTIVE	CLGA	FQP	54	100	RoHS & Green	Call TI	Level-1-NC-NC	-40°C to 90°C	

- (1) The marketing status values are defined as follows:  
**ACTIVE:** Product device recommended for new designs.  
**LIFEBUY:** TI has announced that the device will be discontinued, and a lifetime-buy period is in effect.  
**NRND:** Not recommended for new designs. Device is in production to support existing customers, but TI does not recommend using this part in a new design.  
**PRE\_PROD** Unannounced device, not in production, not available for mass market, nor on the web, samples not available.  
**PREVIEW:** Device has been announced but is not in production. Samples may or may not be available.  
**OBSOLETE:** TI has discontinued the production of the device.
- (2) Eco Plan - The planned eco-friendly classification: Pb-Free (RoHS), Pb-Free (RoHS Exempt), or Green (RoHS & no Sb/Br) - please check <http://www.ti.com/productcontent> for the latest availability information and additional product content details.  
**TBD:** The Pb-Free/Green conversion plan has not been defined.  
**Pb-Free (RoHS):** TI's terms "Lead-Free" or "Pb-Free" mean semiconductor products that are compatible with the current RoHS requirements for all 6 substances, including the requirement that lead not exceed 0.1% by weight in homogeneous materials. Where designed to be soldered at high temperatures, TI Pb-Free products are suitable for use in specified lead-free processes.  
**Pb-Free (RoHS Exempt):** This component has a RoHS exemption for either 1) lead-based flip-chip solder bumps used between the die and package, or 2) lead-based die adhesive used between the die and leadframe. The component is otherwise considered Pb-Free (RoHS compatible) as defined above.  
**Green (RoHS & no Sb/Br):** TI defines "Green" to mean Pb-Free (RoHS compatible), and free of Bromine (Br) and Antimony (Sb) based flame retardants (Br or Sb do not exceed 0.1% by weight in homogeneous material)
- (3) MSL, Peak Temp. -- The Moisture Sensitivity Level rating according to the JEDEC industry standard classifications, and peak solder temperature.
- (4) There may be additional marking, which relates to the logo, the lot trace code information, or the environmental category on the device
- (5) Multiple Device markings will be inside parentheses. Only on Device Marking contained in parentheses and separated by a "~" will appear on a device. If a line is indented then it is a continuation of the previous line and the two combined represent the entire Device Marking for that device.  
**Important Information and Disclaimer:** The information provided on this page represents TI's knowledge and belief as of the date that it is provided. TI bases its knowledge and belief on information provided by third parties, and makes no representation or warranty as to the accuracy of such information. Efforts are underway to better integrate information from third parties. TI has taken and continues to take reasonable steps to provide representative and accurate information but may not have conducted destructive testing or chemical analysis on incoming materials and chemicals. TI and TI suppliers consider certain information to be proprietary, and thus CAS numbers and other limited information may not be available for release.  
 In no event shall TI's liability arising out of such information exceed the total purchase price of the TI part(s) at issue in this document sold by TI to Customer on an annual basis.

© COPYRIGHT 2017 TEXAS INSTRUMENTS  
UN-PUBLISHED. ALL RIGHTS RESERVED.

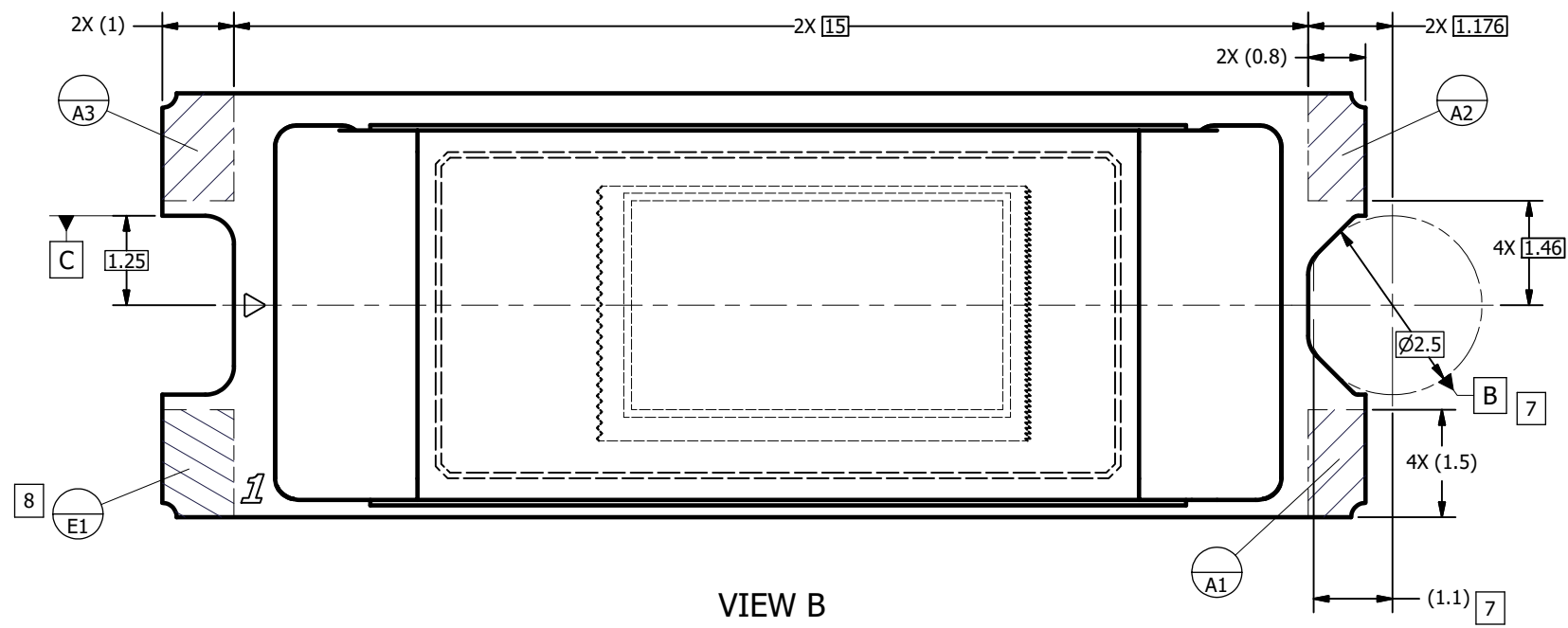
REVISIONS			
REV	DESCRIPTION	DATE	BY
A	ECO 2168534: INITIAL RELEASE	9/5/2017	BMH
B	ECO 2168970: CORRECT SUBSTRATE THICKNESS TOL; ENLARGE APERTURE SLIGHTLY	9/15/17	BMH
C	ECO 2186788: ADD APERTURE SLOT PICTORIALY	4/7/2020	BMH

- NOTES UNLESS OTHERWISE SPECIFIED:
- 1 DIE PARALLELISM TOLERANCE APPLIES TO DMD ACTIVE ARRAY ONLY.
  - 2 ROTATION ANGLE OF DMD ACTIVE ARRAY IS A REFINEMENT OF THE LOCATION TOLERANCE AND HAS A MAXIMUM ALLOWED VALUE OF 0.6 DEGREES.
  - 3 BOUNDARY MIRRORS SURROUNDING THE DMD ACTIVE ARRAY.
  - 4 NOTCH DIMENSIONS ARE DEFINED BY UPPERMOST LAYERS OF CERAMIC, AS SHOWN IN SECTION A-A.
  - 5 ENCAPSULANT TO BE CONTAINED WITHIN DIMENSIONS SHOWN IN VIEW C (SHEET 2). NO ENCAPSULANT IS ALLOWED ON TOP OF THE WINDOW.
  - 6 ENCAPSULANT NOT TO EXCEED THE HEIGHT OF THE WINDOW.
  - 7 DATUM B IS DEFINED BY A DIA. 2.5 PIN, WITH A FLAT ON THE SIDE FACING TOWARD THE CENTER OF THE ACTIVE ARRAY, AS SHOWN IN VIEW B (SHEET 2).
  - 8 WHILE ONLY THE THREE DATUM A TARGET AREAS A1, A2, AND A3 ARE USED FOR MEASUREMENT, ALL 4 CORNERS SHOULD BE CONTACTED, INCLUDING E1, TO SUPPORT MECHANICAL LOADS.

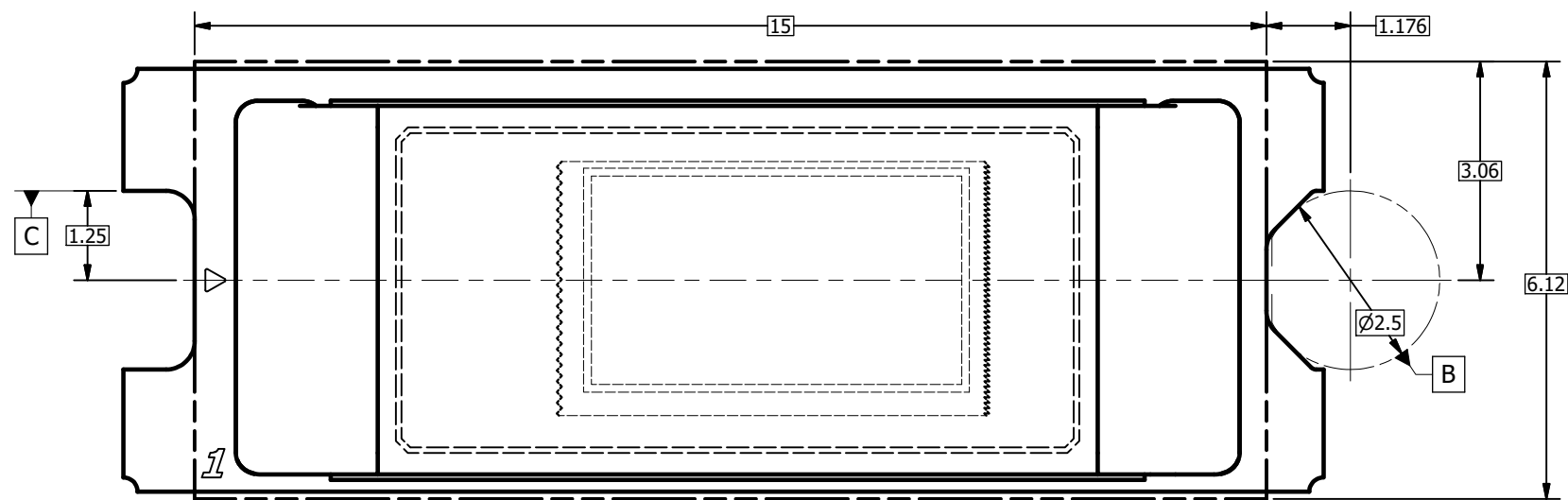


SECTION A-A  
(ROTATED 90°)  
SCALE 20 : 1

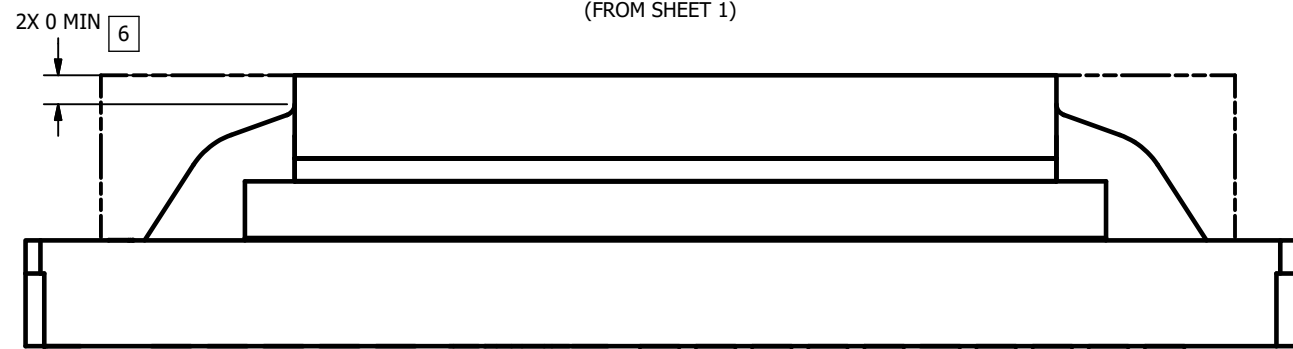
UNLESS OTHERWISE SPECIFIED ● DIMENSIONS ARE IN MILLIMETERS ● TOLERANCES: ANGLES ± 1° 2 PLACE DECIMALS ± 0.25 1 PLACE DECIMALS ± 0.50 ● DIMENSIONAL LIMITS APPLY BEFORE PROCEEDING ● INTERPRET DIMENSIONS IN ACCORDANCE WITH ASME Y14.5M-1994 ● REMOVE ALL BURRS AND SHARP EDGES ● PARENTHETICAL INFORMATION FOR REFERENCE ONLY	DRAWN B. HASKETT ENGINEER B. HASKETT QA/CE P. KONRAD CM J. GRIMMETT M. DORAK APPROVED R. LONG	DATE 9/5/2017 9/5/2017 9/10/2017 9/6/2017 9/5/2017 9/11/2017	TEXAS INSTRUMENTS Dallas, Texas TITLE ICD, MECHANICAL, DMD, .23 TRP SERIES 246 (FQP PACKAGE)
	APPLICATION NEXT ASSY USED ON 0314DA	SIZE D SCALE 20:1	DWG NO. 2515699 SHEET 1 OF 3



VIEW B  
 DATUMS A, B, C, AND E  
 (FROM SHEET 1)

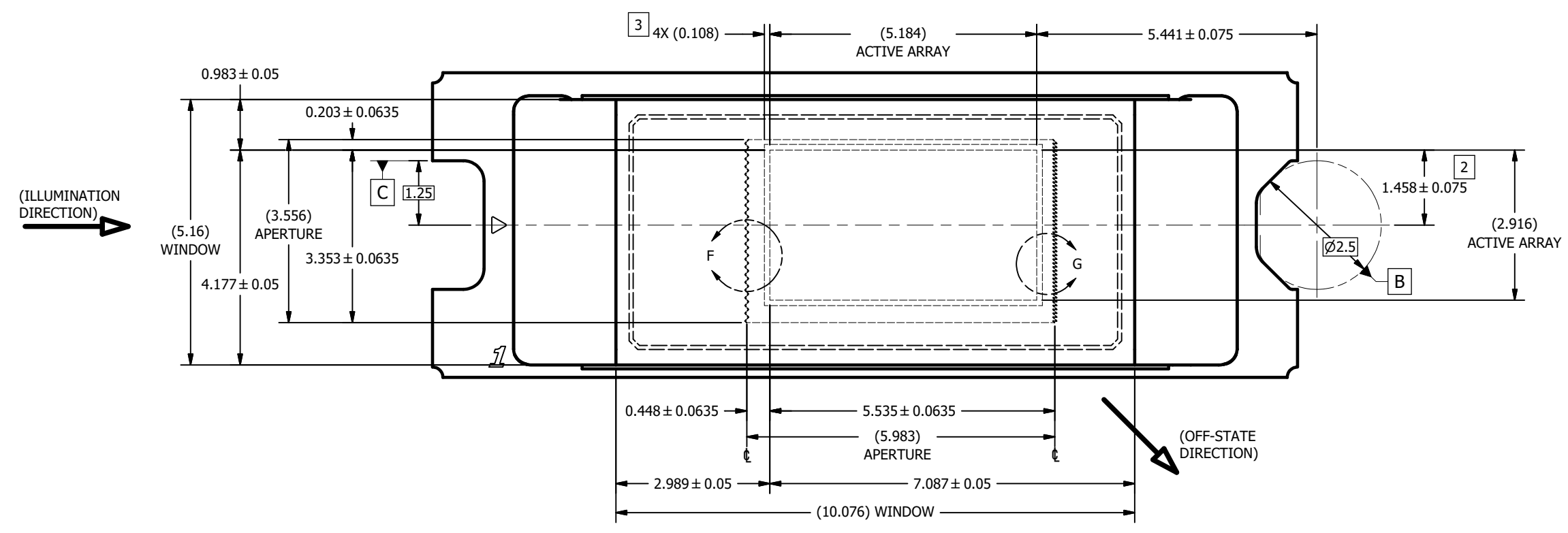


VIEW C <sup>5</sup>  
 ENCAPSULANT MAXIMUM X/Y DIMENSIONS  
 (FROM SHEET 1)

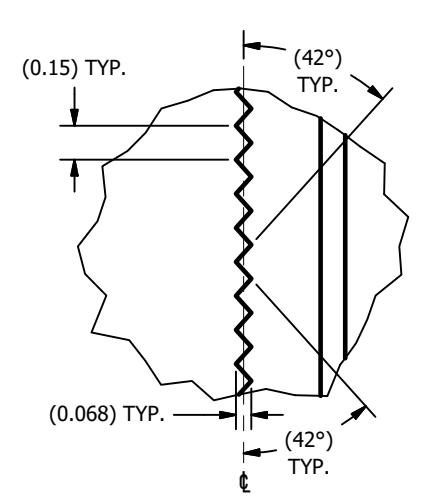


VIEW D  
 ENCAPSULANT MAXIMUM HEIGHT

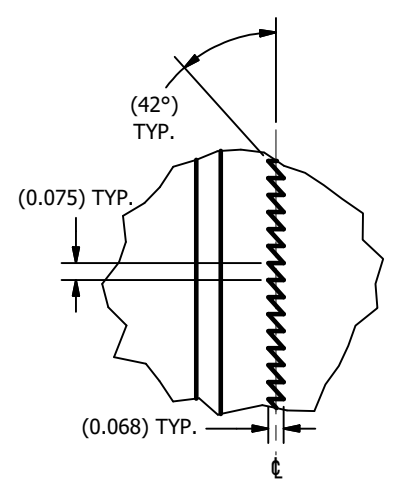




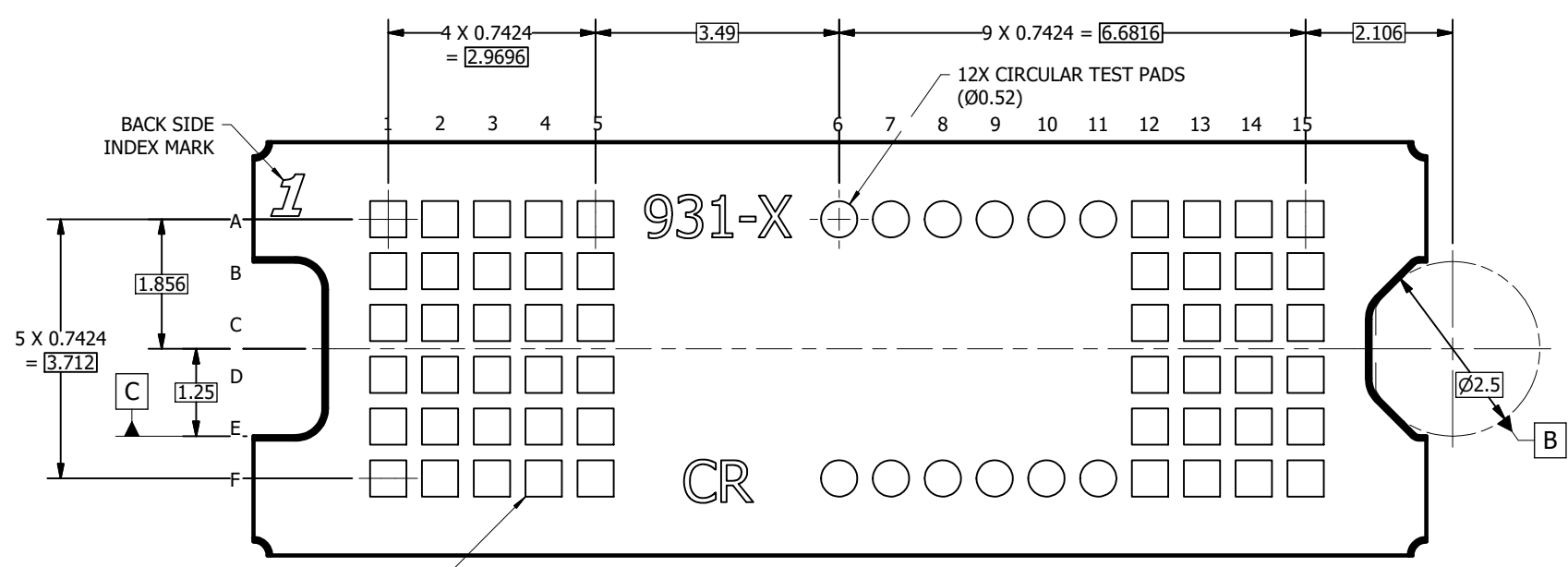
**VIEW E**  
WINDOW AND ACTIVE ARRAY  
(FROM SHEET 1)



**DETAIL F**  
APERTURE LEFT EDGE  
SCALE 60 : 1



**DETAIL G**  
APERTURE RIGHT EDGE  
SCALE 60 : 1



**VIEW H-H**  
BACK SIDE METALLIZATION  
(FROM SHEET 1)

## IMPORTANT NOTICE AND DISCLAIMER

TI PROVIDES TECHNICAL AND RELIABILITY DATA (INCLUDING DATA SHEETS), DESIGN RESOURCES (INCLUDING REFERENCE DESIGNS), APPLICATION OR OTHER DESIGN ADVICE, WEB TOOLS, SAFETY INFORMATION, AND OTHER RESOURCES "AS IS" AND WITH ALL FAULTS, AND DISCLAIMS ALL WARRANTIES, EXPRESS AND IMPLIED, INCLUDING WITHOUT LIMITATION ANY IMPLIED WARRANTIES OF MERCHANTABILITY, FITNESS FOR A PARTICULAR PURPOSE OR NON-INFRINGEMENT OF THIRD PARTY INTELLECTUAL PROPERTY RIGHTS.

These resources are intended for skilled developers designing with TI products. You are solely responsible for (1) selecting the appropriate TI products for your application, (2) designing, validating and testing your application, and (3) ensuring your application meets applicable standards, and any other safety, security, regulatory or other requirements.

These resources are subject to change without notice. TI grants you permission to use these resources only for development of an application that uses the TI products described in the resource. Other reproduction and display of these resources is prohibited. No license is granted to any other TI intellectual property right or to any third party intellectual property right. TI disclaims responsibility for, and you will fully indemnify TI and its representatives against, any claims, damages, costs, losses, and liabilities arising out of your use of these resources.

TI's products are provided subject to [TI's Terms of Sale](#) or other applicable terms available either on [ti.com](#) or provided in conjunction with such TI products. TI's provision of these resources does not expand or otherwise alter TI's applicable warranties or warranty disclaimers for TI products.

TI objects to and rejects any additional or different terms you may have proposed.

Mailing Address: Texas Instruments, Post Office Box 655303, Dallas, Texas 75265  
Copyright © 2022, Texas Instruments Incorporated